

Houses and Low Rise
Multi- Residential
PowerPattern[®]
External Walls
INSTALLATION GUIDE



THIS INSTALLATION GUIDE MUST BE USED IN CONJUNCTION WITH THE HOUSES AND LOW RISE MULTI RESIDENTIAL POWERPANEL^{XL} EXTERNAL WALLS DESIGN & INSTALLATION GUIDE HELIT016

This Design and Installation Guide has been prepared as a source of information to provide general guidance to consultants – and in no way replaces the services of the professional consultant and relevant engineers designing the project.

It is the responsibility of the architectural designer and engineering parties to ensure that the details in this Design and Installation Guide are appropriate for the intended application.

The recommendations of this guide are formulated along the lines of good building practice, but are not intended to be an exhaustive statement of all relevant data.

CONTENTS

Introduction	1
1. Design and selection details	2
1.1 System Components	2
2. Installation Steps	5
2.1 Installation Steps	4
3. System performance	5
3.1 Fire resistance performance	5
3.2 Energy efficiency	6
3.3 Sound transmission and insulation	10
4. Handling, storage and responsibility	11
4.1 Delivery and storage	11
4.2 Panel handling	12
4.3 Design, detailing and performance responsibilities	13
Appendices	14
Appendix A: Hebel PowerPattern material properties	14
Appendix B: Dulux Acratex coating system for Hebel PowerPattern®	15
Appendix C: Rockcote coating system for CSR Hebel PowerPattern®	20

PowerPattern® Track

Hebel's PowerPattern Track collection provides a contemporary option for facades with routed vertical lines into the face of the panel that are ready to install. The "V" groove lines are available in 100mm, 150mm, 200mm or 300mm intervals and as a plain panel with no grooves (bevelled long edges).

Features and benefits:

- Decorative pattern with all the material benefits of Hebel AAC.
- Paintable surface finish providing unlimited colour options for design flexibility. Can also be rendered for texture options.
- Strong 75mm thick, steel reinforced panels provide a solid wall with deep window reveals.
- Maintains strong Hebel thermal and outstanding fire performance.
- Suitable for timber or steel frame construction.

Acoustic: $R_w + C_{tr}$ 45 to 48 based on a 210mm wall system thickness.

Thermal: R2.06 to R3.22.

Common Wall Thickness: 199mm, based on 90mm stud + 10mm plasterboard + 24mm top hat + 75mm PowerPattern. With variations in stud thickness and top hats, wall widths can vary between 179mm to 210mm.

Fire:

All Hebel AAC products are suitable for use where non-combustible building materials are required in accordance with Clause C1.9 and Part 3.7.1 of the Building Code of Australia.

Hebel products are suitable for use in bushfire and flamezone construction.

Coating system:

Panels should be coated with a suitable and compatible acrylic coating system.

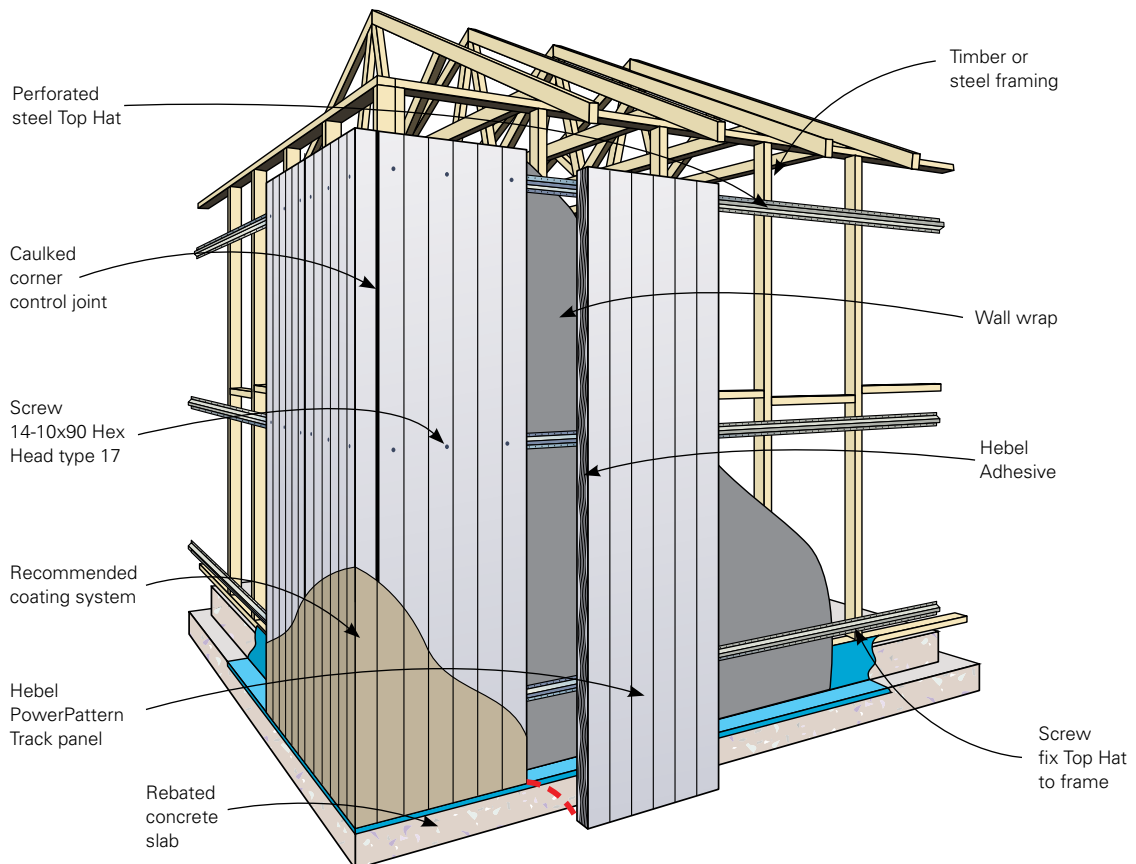

1.1 SYSTEM COMPONENTS

STANDARD PANEL SIZES

- 2400mm x 600mm x 75mm
- 2700mm x 600mm x 75mm
- 2850mm x 600mm x 75mm
- 3000mm x 600mm x 75mm
- 3300mm x 600mm x 75mm

PowerPattern Track routed "V" groove lines are available in 100mm, 150mm, 200mm and 300mm spacing. Also available as a plain panel with no groove (bevelled long edges).

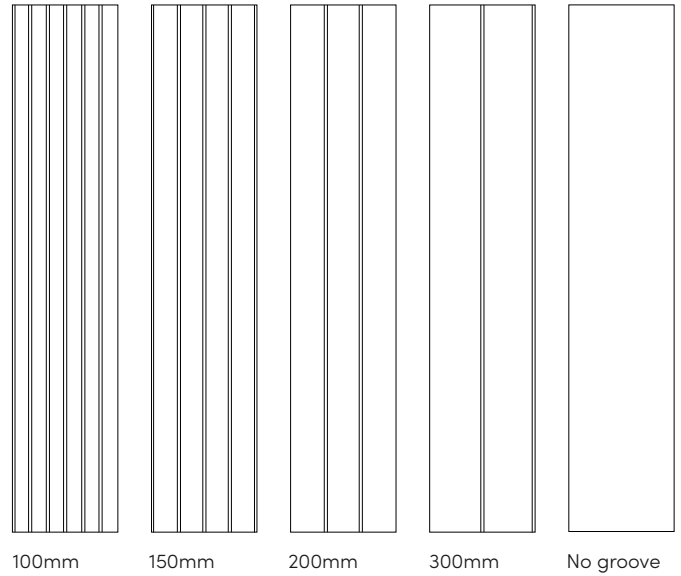

100mm 150mm 200mm





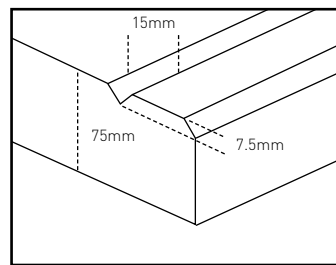





300mm No groove
(bevelled long edges)



"V" groove details

Table 1.1 PowerPattern Track Panel Codes

Groove Width	Panel Length (mm)				
	2400	2700	2850	3000	3300
100mm	454740	454742	454744	454745	454746
150mm	456713	456715	456717	456718	456719
200mm	454748	454750	454752	454753	454754
300mm	454756	454758	454760	454761	454762
Plain (Bevelled long edges)	NA	NA	NA	467570	NA

Codes	System Elements	Application	
See Table 1.1 on Page 2	Hebel PowerPattern Track panels	External Wall System	
21909 - 24mm Top Hat 105536 - 35mm Top Hat	Perforated Top Hat 24mm x 4.8m x 0.42mm BMT or 35mm x 4.8m x 0.55mm BMT	Attaches PowerPattern to frame	
106882	Screws to fix Top Hat to timber framing Screw 12-11 x 35mm Hex Head type 17	Fixes Top Hat to timber frame	
21906	Screws to fix Top Hat to steel framing Screw 10-16 x 16mm Hex Head Tek, self drilling. Note: take care not to strip screws.	Fixes Top Hat to steel frame	
125747	Screws to fix PowerPattern to Top Hat Screw 14-10 x 90mm Hex Head type 17	Fixes PowerPattern to Top Hat	
25594	Hebel Anti-Corrosion Paint 500ml	Used for coating exposed reo at panel edges after cutting	
21933	Hebel Adhesive 20kg bag	Used on all panel joints (except control joints)	
122116	CSR Fire Seal	Used on panel joints including control joints	

2.1 INSTALLATION STEPS

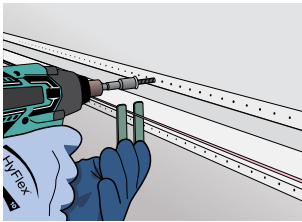

Step 1

Fix Hebel Perforated top hats to timber or steel frame ensuring they are plumb and level.



Step 4

Install PowerPatternTrack panels vertically by applying Hebel Adhesive at joints and screw off to perforated top hats.

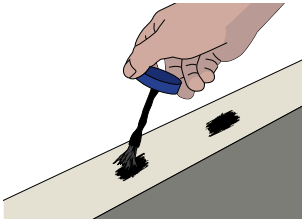

Step 2

Coat any exposed steel reinforcing from cutting with Hebel anti-corrosion paint.

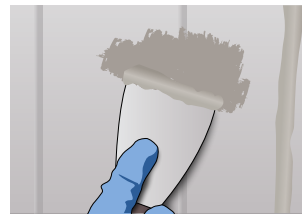

Step 5

Patch minor panel imperfections and screw holes using either Dulux Acratex PowerPatch or Selleys Spakfilla Rapid.

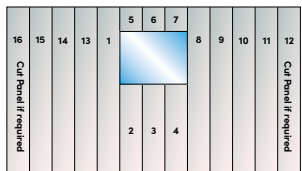

Step 3

Hebel panels are to be installed with the utmost consideration of aesthetics and especially in relation to the position of control joints. Assess panel layout carefully for opening and joint locations to minimise notching of panels.



Step 6

Panels should be coated with a suitable and compatible acrylic coating system.

The Hebel PowerPattern Track collection consists of 75mm thick, steel reinforced Hebel PowerPanel that is factory routed to feature specific design specifications. PowerPattern panels must be installed by following the Hebel Design and Installation recommendations for Hebel PowerPanel^{XL} External Wall Systems.

REFER TO THE HOUSES AND LOW RISE MULTI RESIDENTIAL POWERPANEL^{XL} EXTERNAL WALLS DESIGN & INSTALLATION GUIDE HELIT016 FOR DETAILS REGARDING:

Design and selection details

- Designing an external wall using Hebel PowerPanel^{XL}
- Structural provisions
- Design & detailing considerations
- System components

System performance

- Durability
- Weatherproofing

Installation details

- Hebel PowerPanel^{XL} installation sequence
- Tools and equipment for construction
- Installation of services
- Construction details

3.1 FIRE RESISTANCE PERFORMANCE

OVERVIEW

The Hebel PowerPattern External Wall System can be subjected to a fire loading as the result of either an external fire source, or an internal fire source. When the wall requires a fire resistance level (FRL) rating, Hebel provides the following guidance:

External fire source

For an external fire source, the excellent fire resistance qualities of the Hebel PowerPattern External Wall System protects the structural support framing and provides a high fire resistance level.

NOTE: The FRL rating of the wall can be affected by the penetrations and the method adopted to protect these penetrations. A fire collar with a –/60/60 FRL rating will govern the FRL of the wall, even if the wall configuration has a FRL rating of –/90/90. Where required, the performance of the external coating when subjected to a fire loading shall meet the appropriate performance requirements outlined in the NCC. Joints and gaps need to be appropriately fire rated, e.g. vertical control joint will need fire rated sealant and horizontal joints must be blocked with compressible fire rated material.

Internal fire source

For an internal fire source, the studs must be protected by the internal wall linings. Refer to CSR Gyprock Red Book™ for specifications.

External walls in fire – NCC Provisions

Where necessary the designer and builder should ensure the structural support framing, its connections and the Hebel PowerPattern installation are satisfactory when subjected to fire conditions. The NCC Vol 2 outlines provisions for external walls for fire resistance in a residential building where the external wall is less than 900mm from an allotment boundary or 1.8m from another building on the same allotment. If this occurs an FRL of not less than 60/60/60 is required from the outside.

FIRE PERFORMANCE OF HEBEL POWERPATTERN

The Hebel PowerPattern External Wall System has been assessed by Stephen Grubits & Associates to achieve a Fire Resistance Level (FRL) of up to 120/120/120 mins with the use of a standard grade plasterboard for internal lining.

The same system could achieve an FRL of 180/180/180 with using 1x16 mm Fyrchek plaster board as internal lining. Note, the fire source is considered on the patterned side. This enables Hebel PowerPattern to be used in the following applications:

- Walls on zero line allotment blocks.
- Multi-storey residential dwellings – external walls.

NOTE: In the above applications, each PowerPattern panel should be screwed as specified in this guide, except a minimum of three screws should be installed through the middle top hat into each PowerPattern panel.

DESIGN CONSIDERATIONS

Fire stop penetrations

Penetrations through Hebel PowerPattern to accommodate pipework, electrical cabling or ductwork will have to be protected (fire stop) to prevent the spread of fire through the penetration. The penetration can be protected with proprietary products such as:

- Fire rated sealants
- Fire collars and intumescent wraps
- Fire rated mortars
- Fire rated pillows
- Fire rated switch boxes.

Hebel recommends contacting the manufacturer to obtain the appropriate product/solution and installation method for the application and wall configuration.

3.2 ENERGY EFFICIENCY

NATIONAL CONSTRUCTION CODE (NCC)

The NCC is available in two volumes which align with two groups of 'Class of Building':

- Volume 1 – Class 2 to Class 9 Buildings; and
- Volume 2 – Class 1 & Class 10 Buildings – Housing Provisions.

Each volume presents the Performance Requirements for the efficient use of energy for internal heating and cooling in buildings. The majority of changes have been associated with the Housing Provisions.

The Performance Requirements for energy efficiency ratings are dependent upon the form of construction (i.e. walls or floors), Class of Building, and the type of areas being separated. The performance requirement is a value that is the Total R-Value, which is the cumulative total of the individual R-Values of the building system components.

THE HEBEL POWERPATTERN EXTERNAL WALL SYSTEM

One of the primary design objectives in planning a building is to provide a cost effective comfortable living / working environment for the building's inhabitants. Exploiting the inherent thermal mass and insulation qualities of Hebel enables the designer to achieve this objective.

Several international comparative studies have been conducted to investigate the benefits of incorporating AAC walls in place of conventional wall systems. A common trend was the lower heating and cooling energy consumption and smaller mechanical equipment required to maintain a comfortable living environment, especially with regards to regions of mainly cold weather. The excellent performance was the result of the three characteristics – thermal mass, thermal insulation and the air tightness of the construction.

The level of insulation provided in a wall is determined by the required Total R-Value. The higher the required Total R-Value the greater the insulation provided. Hebel PowerPattern External Wall System incorporating CSR Bradford insulation can provide the R-Value ratings outlined in Tables 2.2.4 and 2.2.5.

THERMAL INSULATION

It is recommended that insulation materials be installed to enhance thermal insulation properties and occupant comfort. Insulation also improves the acoustic performance of the wall against outside noise.

The NCC provides Deemed-to-Satisfy provisions for compliance and installation of the various types of insulation. The insulation should be installed with Hebel PowerPanel^{XL} such that it forms a continuous barrier to contribute to the thermal barrier. All insulation installed in Hebel PowerPattern External Wall systems must comply with: AS/NZS 4859.1; or AS 2464.3 for loose fill insulation.

AIR TIGHTNESS

The thermal performance can be influenced by many factors. Most of these are related to the design decisions and properties of the adopted materials. Construction practices can also significantly affect the performance with poor sealing, resulting in drafts. The tight construction tolerances of AAC provide a wall with low air infiltration rate. Testing at the CSIRO (Test Report DTM327) on Hebel blockwork with thin bed adhesive joints has determined an air infiltration rate of 0.3L/s (0.014% of internal volume). For PowerPanel^{XL} panels having fewer thin bed adhesive joints, a rate less than this could be achieved.

SARKING

As well as controlling condensation and acting as an air barrier, sarking can be used to significantly improve the thermal insulation and energy efficiency performance of a building solution. Sarking layers can alter the performance of the cavity by providing a reflection side. The design of the sarking arrangement is complex and should be performed by the appropriate project consultant.

Where the sarking layer provides a weatherproofing function, the sarking material must comply with AS/NZS 4200 Parts 1 and 2.

The following tables show the performance levels required for walls and floors under the NCC and the thermal performance of the Hebel PowerPattern External Wall System.

Figure 3.2.1 Climate zones for thermal design

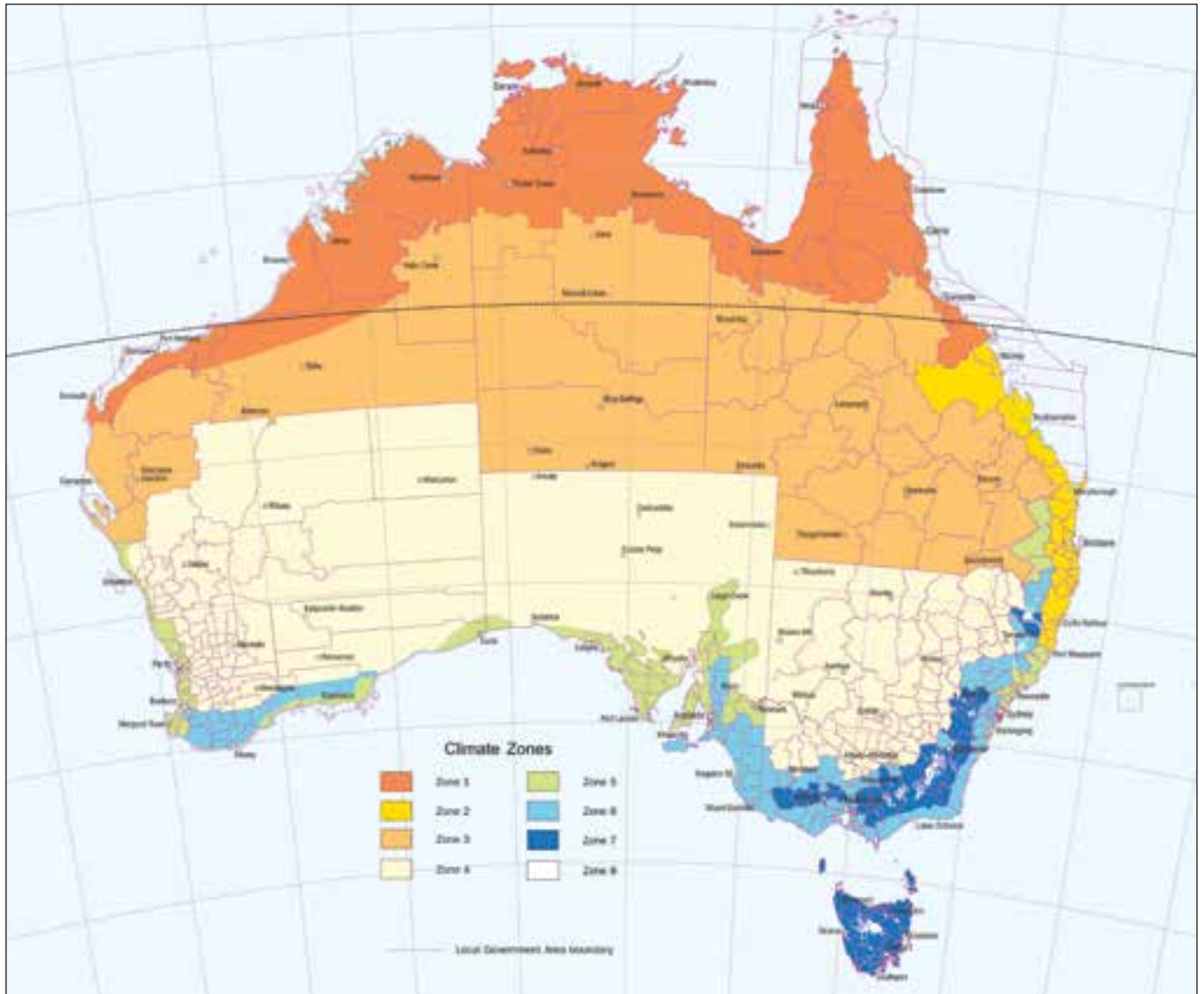

STEP 1 Determine which climate zone your project is located in Australia from the map.

STEP 2 From Table 3.2.1, determine the design conditions ('Summer' heat flow in or 'Winter' heat flow out) according to the building class and climate zone for your project. Note: Building classes are defined by the NCC.

STEP 3 Refer to the roof, wall or floor system applicable to your construction type to determine Total R-Value.

NOTE: Some applications may achieve Total R-Values sufficient to comply with the minimum performance levels of the Deemed-to-Satisfy requirements contained in the Energy Efficiency Provision of the NCC.

Table 3.2.1 Climate zones for thermal design

Climate Zone	1	2	3	4	5	6	7	8
	Below 300metres		Above 300metres					
Class 1-10,2,3,4,9c	Summer		Winter					
Class 5,6,7,8,9a,9b	Summer						Winter	
Class 1-10	Summer		Winter					
Class 2,3,4,5,6,7,8,9a,9b,9c	Summer			Winter				

Table 3.2.2 Low-rise multi-residential buildings

Climate Zone	Options		
1, 2,3,4 and 5	(a)	(i)	Achieve a minimum <i>Total R-Value</i> of 2.8.
	(b)	(i) (ii)	Achieve a minimum <i>Total R-Value</i> of 2.4; and Shade the external wall of the storey with a verandah, balcony, eaves, carport or the like, which projects at a minimum angle of 15 degrees in accordance with Figure 3.12.1.2. of NCC 2019.
6 and 7	Achieve a minimum <i>Total R-Value</i> of 2.8.		
8	Achieve a minimum <i>Total R-Value</i> of 3.8.		

Table 3.2.3 Comparison of thermal properties

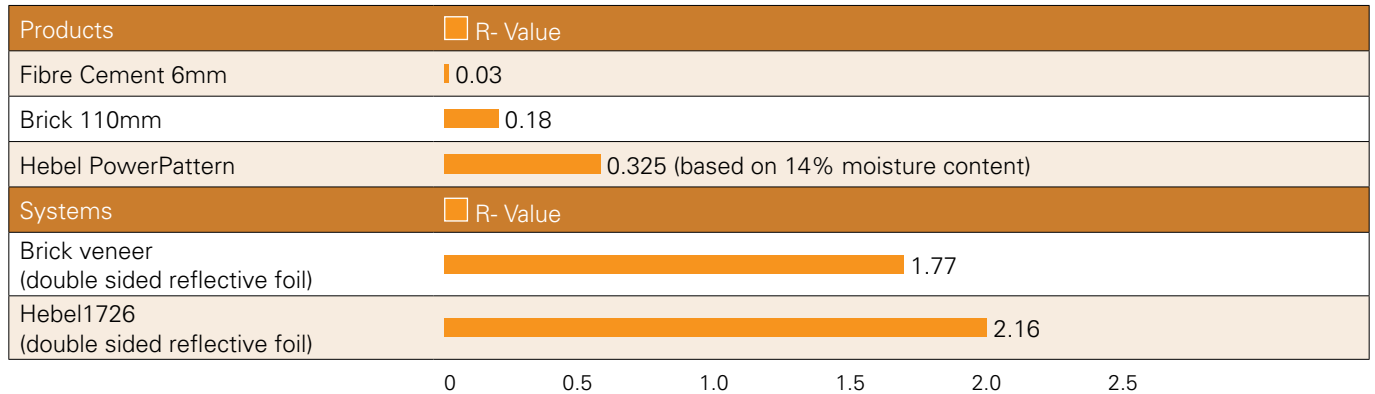

NOTES:

- Sarking or insulation to be added to the above values where applicable to comply with NCC climate zone requirements.
- R-Values above (excluding Hebel PowerPattern solution) are taken from NCC 2019.
- Refer to Table 3.2.4 and 3.2.5 for Hebel PowerPattern configuration and thermal insulation options.
- R-Values provided for brick veneer have been provided by James Fricker calculation 107.50 dated July, 2010.

Table 3.2.4 Thermal performance of Hebel PowerPattern External Wall System - timber stud frame

Hebel code	Description						Total R-value m ² .K/W	
	Plasterboard	Stud frame	Batts	Wall wrap	Top hat cavity	Hebel Panel	Summer	Winter
Hebel2134	10mm Gyprock Plasterboard Plus	70mm timber Stud frame	None	Polyair Performa 4.0 XHD	24mm	75mm thick Hebel PowerPattern	1.90	2.00
Hebel2137			70mm Bradford Soundscreen Batts R2.0	Thermoseal Wall Wrap XP			3.00	3.20
Hebel2138			70mm Bradford Soundscreen Batts R2.0	Enviroseal ProctorWrap RW			2.70	2.80
Hebel2139			None	Polyair Performa 4.0 XHD	35mm		1.90	2.00
Hebel2142			70mm Bradford Soundscreen Batts R2.0	Thermoseal Wall Wrap XP			3.00	3.20
Hebel2143			70mm Bradford Soundscreen Batts R2.0	Enviroseal ProctorWrap RW			2.70	2.80
Hebel2144		90mm timber Stud frame	None	Polyair Performa 4.0 XHD	24mm	1.90	2.00	
Hebel2147			90mm Bradford Gold Wall Batts R2.0	Thermoseal Wall Wrap XP		3.00	3.20	
Hebel2148			90mm Bradford Gold Wall Batts R2.5	Enviroseal ProctorWrap RW		3.20	3.30	
Hebel2149			90mm Bradford Gold Wall Batts R2.7	Enviroseal ProctorWrap RW	3.40	3.50		
Hebel2150			None	Polyair Performa 4.0 XHD	35mm	1.90	2.00	
Hebel2153			90mm Bradford Gold Wall Batts R2.0	Thermoseal Wall Wrap XP		3.00	3.20	
Hebel2154			90mm Bradford Gold Wall Batts R2.5	Enviroseal ProctorWrap RW		3.20	3.30	
Hebel2155			90mm Bradford Gold Wall Batts R2.7	Enviroseal ProctorWrap RW		3.40	3.50	

Table 3.2.5 Thermal performance of Hebel PowerPattern External Wall System - steel stud frame

Hebel code	Description						Total R-value m ² .K/W	
	Platerboard	Stud frame	Batts	Wall wrap	Top hat cavity	Hebel Panel	Summer	Winter
Hebel2156	10mm Gyprock Plasterboard Plus	64mm steel Stud frame	None	Polyair Performa 4.0 XHD	24mm	75mm thick Hebel PowerPattern	1.90	2.00
Hebel2157			70mm Bradford Soundscreen Batts R2.0	Thermoseal Wall Wrap XP			2.90	3.00
Hebel2158			70mm Bradford Soundscreen Batts R2.0	Enviroseal ProctorWrap RW			2.50	2.70
Hebel2159			None	Polyair Performa 4.0 XHD	35mm		1.90	2.00
Hebel2160			70mm Bradford Soundscreen Batts R2.0	Thermoseal Wall Wrap XP			2.90	3.00
Hebel2161			70mm Bradford Soundscreen Batts R2.0	Enviroseal ProctorWrap RW			2.50	2.70
Hebel2170		92mm steel Stud frame	None	Polyair Performa 4.0 XHD	24mm		1.90	2.00
Hebel2171			90mm Bradford Gold Wall Batts R2.0	Thermoseal Wall Wrap XP			3.00	3.20
Hebel2172			90mm Bradford Gold Wall Batts R2.5	Enviroseal ProctorWrap RW			3.20	3.30
Hebel2173			90mm Bradford Gold Wall Batts R2.7	Enviroseal ProctorWrap RW			3.40	3.50
Hebel2174			None	Polyair Performa 4.0 XHD	35mm		1.90	2.00
Hebel2175			90mm Bradford Gold Wall Batts R2.0	Thermoseal Wall Wrap XP			3.00	3.20
Hebel2176			90mm Bradford Gold Wall Batts R2.5	Enviroseal ProctorWrap RW			3.20	3.30
Hebel2177			90mm Bradford Gold Wall Batts R2.7	Enviroseal ProctorWrap RW			3.40	3.50

Table 3.2.6 Guidance on wall wrap/sarking

Performance criteria	Guidance on wall wrap/sarking	Recommended wall wrap/ sarking	Reflective or non-reflective
Vapour barrier	Vapour barrier products are not recommended for condensation control in colder climate zones in conjunction with high insulation R Values.	Polyair Performa 4.0 XHD	Reflective double-sided
		Thermoseal Wall Wrap XP	Reflective single-sided
Vapour permeable	Vapour permeable products are not recommended for use in tropical climate zones.	Enviroseal ProctorWrap RW	Non-reflective

NOTES:

1. Refer to NCC for state & territory variations.
2. Refer to NCC for alternative means of satisfying the required performance levels.
3. Refer to CSR Bradford product literature for design & installation requirements on wall wrap/ sarking and insulation.
4. The density of Gyprock plasterboard plus is 5.7 kg/m².
5. Stated R-values in Tables 3.2.4 and 3.2.5 has been provided by J.Fricke calculations in report i107e, dated 01/10/2020. Determinations based upon AS/NZS 4859:2018, including thermal bridging.
6. Stated R-values in Tables 3.2.4 and 3.2.5 includes 6mm skim render.
7. As per NCC 2019, where wall wrap is installed in an external wall it must be vapour permeable wall wrap for climate zones 6,7 and 8.

3.3 SOUND TRANSMISSION & INSULATION

OVERVIEW

Current NCC sound transmission and insulation requirements

The Hebel PowerPattern External Wall System is primarily used in buildings that have a domestic type of activity purpose. The NCC generally classifies these buildings into Class 1 or 10. The acoustic performance requirements for external walls in these buildings or their building elements are not currently stated in the NCC. If a building using the Hebel wall system was required to provide acoustic performance, then the performance level requirements for a building envelope and elements would be set by the relevant authorities (i.e. local councils, client specific requirements, etc).

Design recommendations

Acoustic design is a complex science and there will be instances where a specialist acoustic consultant is required.

For walls requiring acoustic performance Hebel recommends:

1. Engaging a reputable acoustic consultant on a project-by-project basis to provide design advice and installation inspections
2. When selecting the appropriate components for the Hebel wall system, the designer or specifier must be aware that the laboratory R_w values are almost always higher than the field measured values. Therefore, allowances should be made for the lower expected field values during the selection of the system
3. Separate advice from a specialist acoustic consultant should be sought to determine the effect on acoustic performance due to any changes to the Hebel wall system, and any required modification of the installation details pertaining to the systems
4. Increasing cavity widths, using higher density or thicker insulation or plasterboard, will generally maintain or increase the acoustic performance of the Hebel wall system.

Table 3.3.1 Acoustic performance of Hebel PowerPattern External Wall System - timber stud frame

Hebel code	Description						Acoustic	
	Plasterboard	Stud frame	Batts	Wall wrap	Top hat cavity	Hebel Panel	R_w	$R_w + C_{tr}$
Hebel2134	10mm Gyprock Plasterboard Plus	70mm timber Stud frame	None	Polyair Performa 4.0 XHD	24mm	75mm thick Hebel PowerPattern	44	36
Hebel2137			70mm Bradford Soundscreen Batts R2.0	Thermoseal Wall Wrap XP			49	40
Hebel2138			70mm Bradford Soundscreen Batts R2.0	Enviroseal ProctorWrap RW			49	40
Hebel2139			None	Polyair Performa 4.0 XHD	35mm		45	36
Hebel2142			70mm Bradford Soundscreen Batts R2.0	Thermoseal Wall Wrap XP			49	40
Hebel2143			70mm Bradford Soundscreen Batts R2.0	Enviroseal ProctorWrap RW			49	40
Hebel2144		90mm timber Stud frame	None	Polyair Performa 4.0 XHD	24mm		46	37
Hebel2147			90mm Bradford Gold Wall Batts R2.0	Thermoseal Wall Wrap XP			49	40
Hebel2148			90mm Bradford Gold Wall Batts R2.5	Enviroseal ProctorWrap RW			49	40
Hebel2149			90mm Bradford Gold Wall Batts R2.7	Enviroseal ProctorWrap RW	49		40	
Hebel2150			None	Polyair Performa 4.0 XHD	35mm		46	37
Hebel2153			90mm Bradford Gold Wall Batts R2.0	Thermoseal Wall Wrap XP			50	41
Hebel2154			90mm Bradford Gold Wall Batts R2.5	Enviroseal ProctorWrap RW			50	41
Hebel2155			90mm Bradford Gold Wall Batts R2.7	Enviroseal ProctorWrap RW	50		41	

Table 3.3.2 Acoustic performance of Hebel PowerPattern External Wall System - steel stud frame

Hebel code	Description						Acoustic	
	Plasterboard	Stud frame	Batts	Wall wrap	Top hat cavity	Hebel Panel	R_w	$R_w + C_{tr}$
Hebel2156	10mm Gyprock Plasterboard Plus	64mm steel Stud frame	None	Polyair Performa 4.0 XHD	24mm	75mm thick Hebel PowerPattern	44	36
Hebel2157			70mm Bradford Soundscreen Batts R2.0	Thermoseal Wall Wrap XP			49	38
Hebel2158			70mm Bradford Soundscreen Batts R2.0	Enviroseal ProctorWrap RW			49	38
Hebel2159			None	Polyair Performa 4.0 XHD	35mm		44	36
Hebel2160			70mm Bradford Soundscreen Batts R2.0	Thermoseal Wall Wrap XP			50	40
Hebel2161			70mm Bradford Soundscreen Batts R2.0	Enviroseal ProctorWrap RW			50	40
Hebel2170		92mm steel Stud frame	None	Polyair Performa 4.0 XHD	24mm		46	37
Hebel2171			90mm Bradford Gold Wall Batts R2.0	Thermoseal Wall Wrap XP			51	41
Hebel2172			90mm Bradford Gold Wall Batts R2.5	Enviroseal ProctorWrap RW			51	41
Hebel2173			90mm Bradford Gold Wall Batts R2.7	Enviroseal ProctorWrap RW	51		41	
Hebel2174			None	Polyair Performa 4.0 XHD	35mm		46	37
Hebel2175			90mm Bradford Gold Wall Batts R2.0	Thermoseal Wall Wrap XP			51	41
Hebel2176			90mm Bradford Gold Wall Batts R2.5	Enviroseal ProctorWrap RW			51	41
Hebel2177			90mm Bradford Gold Wall Batts R2.7	Enviroseal ProctorWrap RW	51		41	

NOTE:

1. Acoustic values in Tables 3.3.1 and 3.3.2 are based on acoustic assessment 20171728.20/0110A/R2/TB.
2. Acoustic values in tables 3.3.1 and 3.3.2 are based on 600mm stud spacings. For acoustic data on 450mm stud spacings please contact Hebel Technical services.

4.1 DELIVERY AND STORAGE

UNLOADING PANEL PACKS

Panel packs should only be unloaded and moved with approved lifting devices. Before use, the lifting devices should be checked for the required lifting tags. Packs should be unloaded as close as possible to the intended installation area. This will increase work efficiency and minimise the need for secondary lifting.

NOTE: Secondary handling increases the risk of panel damage. The repair of damage sustained during lifting and moving is the responsibility of the lifter. Where damage is excessive, PowerPattern panels must be replaced.

STORAGE

All materials must be kept dry and preferably stored undercover. Care should be taken to avoid sagging or damage to ends, edges and surfaces.

All Hebel products must be stacked on edge and properly supported off the ground, on a level platform. Panel bundles can be stacked two high. The project engineer should be consulted as to the adequacy of the structure to support the stacked bundles.

If outside, Hebel panels must be stored off the ground and protected from the weather. Only single bundles positioned

on the ground can be opened. To provide a level surface, we recommend placing temporary joists beneath the supporting cleats.

UNSTRAPPING PACKS

Ensure appropriate bracing is installed to packs prior to removal of strapping to prevent panels from falling.

Panels can be held together with sash clamps, ratchet straps or Hebel stabilising bars.



Figure 4.1.1 Stacking packs of Hebel PowerPattern Track panels

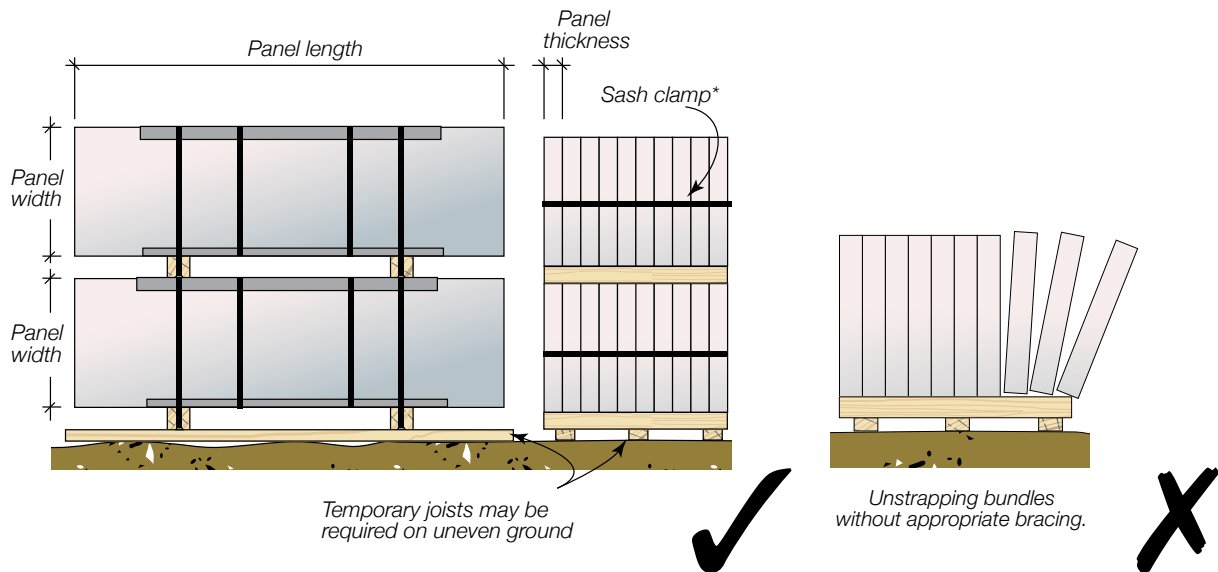

4.2 PANEL HANDLING

MANUAL HANDLING

Hebel recommends using a trolley or other mechanical apparatus to move the panels around the work site. Manual handling where people physically move a panel should be kept to a minimum, with the weight being supported by an individual kept as small as possible. Any concerns regarding the weight to be handled should be discussed with the panel installation contractor.

To minimise the possibility of manual handling injuries, Hebel suggests the following:

- Use mechanical aids, such as trolleys, forklifts, cranes and levers, or team lifting to move panels
- Keep the work place clean to reduce the risk of slips, trips and falls, which can cause injury
- Plan the sequence of installation to minimise panel movements and avoid awkward lifts
- Train employees in good lifting techniques to minimise the risk of injury.

Figure 4.2.1 Hebel PowerPanel Trolley



MECHANICALLY ASSISTED HANDLING

Moving and handling Hebel panels should be done as much as possible using mechanical aids such as forklifts, cranes and special panels lifting trolleys.

Guidelines for handling Hebel panels using the PowerPanel Trolley or PowerPanel lifters are detailed in The Hebel Technical Manual Part 6.

HEALTH, SAFETY & PERSONAL PROTECTIVE EQUIPMENT (PPE)

Hebel products are cement-based, which may irritate the skin, resulting in itching and occasionally a red rash. The wearing of gloves and suitable clothing to reduce abrasion and irritation of the skin is recommended when handling Hebel products.

Approved respirators (AS/NZS 1715 and AS/NZS 1716) and eye protection (AS 1336) should be worn at all times when cutting and chasing. Refer to the Hebel Safety Data Sheets (SDS). Refer to the back of this Design & Installation Guide for further information regarding health and safety.

Figure 4.2.3 Personal protective equipment

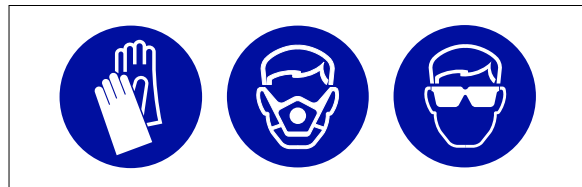

CUTTING

The use of power tools when cutting concrete products may cause dust, which contains respirable crystalline silica, with the potential to cause bronchitis, silicosis and lung cancer after repeated and prolonged exposure. When using power or hand tools on Hebel products, wear a P2 respirator and eye protection. When cutting, routing or chasing Hebel products with power tools, use dust extraction equipment and wear hearing protection. Refer to the appropriate Hebel SDS. For further information, contact Hebel or visit the website: www.hebel.com.au

Reinforcement exposed during cutting **must be** coated with a liberal application of Hebel Anti-corrosion protection paint.



4.3 DESIGN, DETAILING AND PERFORMANCE RESPONSIBILITIES

Hebel engages independent testing laboratories to test and report on the performance of a wall in accordance with the relevant Australian Standards. Consultants use these reports as the basis for opinions (estimates of laboratory performance) they issue for variations or different arrangements to the tested system, and also to design and specify walls that meet appropriate criteria for a particular project. Using their experience, the consultant will make judgement about on-site installed performance of various walls. The performance levels of walls documented in this guide are either what is reported in a test or the documented opinion of consultants. Performance in projects is typically the responsibility of:

PROJECT CONSULTANTS (STRUCTURAL, FIRE, ACOUSTIC, ETC.)

These consultants are typically responsible for the following:

- Opinions on expected laboratory performance of wall configurations that vary from actual test configuration, such as substitution products and components
- Judgements about expected field performance using laboratory test reports and practical experience
- Design, specification and certification of structural, fire, acoustic, durability, weather tightness and any other required performance criteria for individual projects

This involves the design and selection of building elements, such as wall and floors and their integration into the building considering the following:

- Interface of different building elements and to the structure / substrate
- Wall and floor junctions
- Penetrations
- Flashing issues
- Room / building geometry
- Acoustic and water penetration field-testing.

PROJECT CERTIFIER AND/OR BUILDER

These professionals are typically responsible for:

- Identifying the performance requirements for the project in accordance with the National Construction Code and clearly communicating this to the relevant parties.
- Applicability of any performance characteristics supplied by Hebel including test and opinions for the project.
- The project consultant's responsibilities detailed above if one is not engaged in the project.

Hebel does not provide consulting services. Hebel only provides information that has been prepared by others and therefore shall not be considered experts in the field.

Any party using the information contained in this guide or supplied by Hebel in the course of a project must satisfy themselves that it is true, current and appropriate for the application, consequently accepting responsibility for its use.

It is the responsibility of the architectural designer and engineering parties to ensure that the details in this design guide are appropriate for the intended application.

The recommendations in this guide are formulated along the lines of good building practice, but are not intended to be an exhaustive statement of all relevant data.

Hebel is not responsible for the performance of constructed walls, including field performance, and does not interpret or make judgements about performance requirements in the NCC.

APPENDIX A: HEBEL POWERPATTERN TRACK MATERIAL PROPERTIES

A.1 Manufacturing tolerances

Length	±5mm
Width	±1.5mm
Thickness	±1.5mm
Diagonals (max.)	5mm
Edge Straightness Deviation (max.)	1.5mm

A.2 Physical properties

- Profile and nominal dimensions are shown on page 2.
- Panel reinforcement is a single layer of steel mesh with 4 longitudinal wires of 4mm diameter.
- Nominal dry density = 510 kg/m³.
- Average working density = 663 kg/m³ at 30% moisture content.
- Average service life density = 561 kg/m³ at 10% moisture content.

A.3 Strength properties

- Characteristic Compressive Strength or AAC, f'_{cm} = 2.8 MPa.
- Average Compressive Strength of AAC = 3.2 MPa.
- Characteristic Modulus of Rupture, f'_{ut} = 0.60 MPa.

A.4 Acoustic properties

- Panel only with no plasterboard or other lining
 R_w = 36dB, R_w+C_{tr} = 30dB (refer to Acoustic Logic test ATF-676).

A.5 Thermal properties

- R-Value of PowerPattern with no plasterboard or other lining = 0.325 m².K/W (based on 14% moisture content).

A.6 Fire hazard indices

Hebel products have BCA Group Number 1 and also the following early fire hazard indices, determined in accordance with AS1530.3:1990:

Ignitability Index	0
Spread of Flame Index	0
Heat Development Index	0
Smoke Development Index	0-1

A.7 Fire Resistance Level (FRL) Ratings

For fire performance characteristics of Hebel PowerPattern, refer to Section 3.1 of this guide.

APPENDIX B – DULUX ACRATEX COATING SYSTEM FOR CSR HEBEL POWERPATTERN® TRACK

ACRASHIELD MATT 3 COAT SYSTEM OVER SMOOTH AND FLUSH PANEL

Substrate:

CSR Hebel Autoclaved Aerated Concrete (AAC) is produced in panels for both load bearing and non-load bearing uses in various thicknesses, densities and designs relative to specification.

The PowerPattern System consists of 75mm thick, steel-reinforced Hebel PowerPanel, factory routed to various feature design specifications and installed following Hebel Design & Installation recommendations. Panel installation includes full gluing of panel joints with Hebel Adhesive as per Hebel PowerPanel installation guidelines.

Users of this specification will satisfy themselves of the suitability of this specification / advice, relevant to their specific project requirements. In all cases Building System Design must conform to relevant Local / Building Codes or regulations and be in accordance with substrate supplier's recommendations. Users must make their own determinations as to the suitability of this specification relative to specific project technical & aesthetic requirements.

Substrate Preparation:

Frame detail and panel fixing must comply with relevant building codes and be in strict accordance with CSR Hebel installation instructions & recommendations.

Dulux AcraTex recommends suitable expansion/contraction relief joints be installed at natural building weak points eg in line with openings (window / doors), horizontally between all floor levels, and at all interfaces of different building construction materials and or as defined by Engineer. All fixings must be non-corrosive, suitable for the exposure condition and be in accordance with substrate supplier recommendations.

Face Alignment & Joint Glue Integrity

Panel alignment is critical in all cladding systems and specific attention must be given to control "framing and/or face" alignment. Uneven face alignment will require construction attention prior to coatings installation or "steps" will be evident between panels.

It is particularly important to ensure all PowerPattern joints are completely and fully glued along their entire contact area (panel to panel) and all excess panel adhesive is struck clean leaving the joint fully filled and the routing profile smooth.

It is the responsibility of the panel installers to ensure all joints or major imperfections, misalignments are filled and sanded true & flush before applying any coatings system. **NO Hebel Glue smears** are to be left on the panel faces or joints, remove all surface contaminants such as oil, grease or dirt, dust by hosing down with fresh potable water before application of coatings

Substrate must be cleaned free of all surface contaminants prior to coating. Light sanding of the panel followed by dedusting with a clean water spray is recommended prior to coating.

Control Joints:

Control Joints must be in accordance with CSR Hebel Design & Installation Guide including the incorporation of discontinuous top-hat sections across joints and at corners. Control joints are recommended at (max)3m height & 6m wide intervals and at building weak points eg in line with openings (window / doors), horizontally between all floor levels, and at all interfaces of different construction materials.

Preparation and Installation of control joints and mastic is the responsibility of the Panel Installer to be completed prior to coating system installation using a suitable (paintable) polyurethane joint sealant. Install sealant in accordance with manufacturer recommendations - CARE is to be used so as not to smear the sealant to either side of the expansion joint recess.

Where specified, skimcoat levelling compounds must NOT be applied over Control Joints

Colour coating over the joint sealant can be accomplished with the specified system topcoat however cracking of topcoat material applied over joint sealants may occur due to the design movement of the joint system. Such cracking will not be considered as a coating system failure.

Panel Fixings and Damage:

Hebel PowerPattern is face fixed in accordance with Hebel Installation Guidelines.

Where roller applied coating systems are specified without skimcoat levelling coat, it is critical to ensure fixings are patched and flushed smooth and with consistent pattern to the raw panel face. Dulux recommends the use of AcraTex PowerPatch Smooth for Screw Fix patching as per coatings system guidelines on following page.

Typically patching of panel damage is the responsibility of the panel installer following Hebel Installation guidelines using Hebel Patch. Where used, Hebel patch must be struck flush and sanded smooth after curing in such a way to replicate the broad wall panel surface. Any Patching smears across the panel surface requiring heavy sanding may result in patchiness after coating.

Duspec	AcraTex 3 Coat AcraShield Coating System for CSR Hebel PowerPattern				Prepared By	Ian Schultz	Page 1 of 5
Duspec No	AU_SA15509-2	Issue No	2	Date	01.04.20	Approved By	

DISCLAIMER:

Any advice, recommendation, information, assistance or service provided by any of the divisions of DuluxGroup Products in relation to goods manufactured by it or their use and application is given in good faith and is believed by DuluxGroup to be appropriate and reliable. However, any advice, recommendation, information, assistance or service provided by DuluxGroup is provided without liability or responsibility PROVIDED THAT the foregoing shall not exclude, limit, restrict or modify the right entitlements and remedies conferred upon any person or the liabilities imposed upon DuluxGroup by any condition or warranty implied by Commonwealth, State or Territory Act or ordinance void or prohibiting such exclusion limitation or modification. Coating systems can be expected to perform as indicated on the Duspec Spec Sheet so long as applications and application procedures of the individual products are followed as recommended on the appropriate Product data Sheet. The data provided within the Duspec system is correct at the time of publication, however it is the responsibility of those using this information to check that it is current prior to specifying or using any of these coating systems. This specification should be read in conjunction with the Product Datasheets specified within this document.

"Dulux" "Berger" "Berger Gold Label" "Hadrian" "Walpamur" "Levene" "AcraTex" are registered trademarks of DuluxGroup Pty Ltd ABN . 67 000 049 427



Patching & Preparation:

CSR HEBEL PowerPattern™ Coating System	Data Sheet	Application Rate	Typical Recoat Time
<p>SCREW FLUSHING & PATCHING - 3-10mm imperfections and screw fixings</p> <p>AcraTex PowerPatch Smooth Product Code : 194X0040-3.4kg</p> <p>For best finish, panel imperfections greater than 3mm should be patched and lightly sanded ready for coating.</p> <ul style="list-style-type: none"> Blowout screw fixing holes to remove all friable material. Apply patching compound to slightly over fill the screw hole or imperfection and allow to firm before striking flush. Allow to cure for 2 -3 hours before sanding depending on weather conditions. <p>Use care in filling and sanding to replicate the as raw panel surface to avoid patchiness after coating. DO NOT smear excess patching compound across the panel face which will create patchiness (i.e. patches will be smoother than the raw panel face)</p> <p>Where major patching is required a full skimcoat of AcraTex AcraPatch Smooth may be required.</p>		<i>Relative to patching required</i>	2 -3 Hours
<p>COATING SYSTEM PREP POST PATCHING</p> <ol style="list-style-type: none"> Lightly sand the entire panel using 120 grit sand paper to smooth blemishes and as final prep including over patched and sanded screw fixings and patches. Dedust the surface with a light water spray just prior to application of the first coat. Allow excess water to dry / absorb (no surface water present). <p>SEALER (Optional - recommended in hot dry conditions)</p> <p>Dulux AcraTex AcraPrime WB Product Code : 19420809-15L</p> <p>Apply by conventional nap roller evenly over the surface to aid application of subsequent coats by unifying substrate suction.</p>	AUDA0441	10 sq m per litre	2 hours
<p>2nd Fix Patching AFTER PRIMING OR FIRST FINISH COAT</p> <p>Selleys SPAK FILLA EXTERIOR RAPID Product Code : 930069711002201</p> <p>Where required, Surface Imperfections evident after priming or first coat should be patched using Selleys Spak Filla Rapid Exterior in accordance with the product instructions.</p> <p>Allow to dry and sand flush – Do not leave raised edges</p>		<i>Relative to patching required</i>	2 -3 Hours

Duspec	AcraTex 3 Coat AcraShield Coating System for CSR Hebel PowerPattern				Prepared By	Ian Schultz	Page 2 of 5
Duspec No	AU_SA15509-2	Issue No	2	Date	01.04.20	Approved By	

DISCLAIMER:

Any advice, recommendation, information, assistance or service provided by any of the divisions of DuluxGroup Products in relation to goods manufactured by it or their use and application is given in good faith and is believed by DuluxGroup to be appropriate and reliable. However, any advice, recommendation, information, assistance or service provided by DuluxGroup is provided without liability or responsibility PROVIDED THAT the foregoing shall not exclude, limit, restrict or modify the right entitlements and remedies conferred upon any person or the liabilities imposed upon DuluxGroup by any condition or warranty implied by Commonwealth, State or Territory Act or ordinance void or prohibiting such exclusion limitation or modification. Coating systems can be expected to perform as indicated on the Duspec Spec Sheet so long as applications and application procedures of the individual products are followed as recommended on the appropriate Product data Sheet

The data provided within the Duspec system is correct at the time of publication, however it is the responsibility of those using this information to check that it is current prior to specifying or using any of these coating systems. This specification should be read in conjunction with the Product Datasheets specified within this document.

"Dulux" "Berger" "Berger Gold Label" "Hadrian" "Walpamur" "Levene" "AcraTex" are registered trademarks of DuluxGroup Pty Ltd ABN . 67 000 049 427



Coating System:

CSR HEBEL PowerPattern™ Coating System	Data Sheet	Application Rate	Typical Recoat Time
<p>1st COAT : AcraTex AcraShield Matt Product Code : 194X0560-15L VW</p> <p>Apply a heavy priming basecoat coat with an 18mm (Medium) premium NAP Roller maintaining a loaded roller to ensure priming and base filling of surface profile</p> <p>Back roll evenly in one direction to create a light even stipple profile.</p> <p>As with all high build roller applications it is recommended to maintain a moving wet edge to apply teams of 2 applicators – 1 applying and a 2nd applicator rolling off.</p>	AUDA1409	4 sq m per litre	2 hours
<p>2nd Fix Patching AFTER PRIMING OR FIRST FINISH COAT</p> <p>Where required, Surface Imperfections evident after priming or first coat should be patched using Selleys Spak Filla Rapid Exterior in accordance with the product instructions.</p> <p>Selleys SPAK FILLA EXTERIOR RAPID Product Code : 930069711002201</p> <p>For best finish, panel imperfections greater than 3 mmm should be patched and lightly sanded ready for coating.</p> <p>Allow to dry and sand flush – Do not leave raised edges</p>		Relative to patching required	2 -3 Hours
<p>2nd COAT : AcraTex AcraShield Matt Product Code : 194X0560-15L VW</p> <p>Apply with an 18mm (Medium) premium NAP Roller ensuring a wet edge is maintained over the application area. Back roll to in one direction to create a light even stipple profile</p>	AUDA1409	5 sq m per litre	2 hours
<p>3rd COAT : AcraTex AcraShield Matt Product Code : 194X0560-15L VW</p> <p>Apply with an 18mm (Medium) premium NAP Roller ensuring a wet edge is maintained over the application area. Back roll to in one direction to create a light even stipple profile</p>	AUDA1409	6 sq m per litre	2 hours

Duspec	AcraTex 3 Coat AcraShield Coating System for CSR Hebel PowerPattern				Prepared By	Ian Schultz		Page 3 of 5
Duspec No	AU_SA15509-2	Issue No	2	Date	01.04.20	Approved By	Ian Schultz	

DISCLAIMER:

Any advice, recommendation, information, assistance or service provided by any of the divisions of DuluxGroup Products in relation to goods manufactured by it or their use and application is given in good faith and is believed by DuluxGroup to be appropriate and reliable. However, any advice, recommendation, information, assistance or service provided by DuluxGroup is provided without liability or responsibility PROVIDED THAT the foregoing shall not exclude, limit, restrict or modify the right entitlements and remedies conferred upon any person or the liabilities imposed upon DuluxGroup by any condition or warranty implied by Commonwealth, State or Territory Act or ordinance void or prohibiting such exclusion limitation or modification. Coating systems can be expected to perform as indicated on the Duspec Spec Sheet so long as applications and application procedures of the individual products are followed as recommended on the appropriate Product data Sheet

The data provided within the Duspec system is correct at the time of publication, however it is the responsibility of those using this information to check that it is current prior to specifying or using any of these coating systems. This specification should be read in conjunction with the Product Datasheets specified within this document.

"Dulux" "Berger" "Berger Gold Label" "Hadrian" "Walpamur" "Levene" "AcraTex" are registered trademarks of DuluxGroup Pty Ltd ABN . 67 000 049 427

High Build Roller Application Technique

IT'S NOT PAINT

Because they are applied 3-5x thicker than standard paint, elastomeric coatings magnify any cut-in, roller edge and delivery unevenness.

CUTTING-IN - WET

Thin cut-in material by 10% with clean water and cut-in only an area you can roll into wet. Finish brushed areas with a "dabbing" motion and feather out. DO NOT leave thick edge lines.

DELIVER - SPREAD - LAY-OFF

- Deliver in overlapping strips - DO NOT leave "gaps" intended to even out on back-rolling as you may for paint.
- Reload the roller after each strip & repeat until a manageable section has been "delivered" (approximately 3-4 strips wide).
- Backroll to spread the material evenly.
- Apply a fresh wet edge strip ahead of your work to create a "working wet edge".
- With an "empty" roller, "lay-off" by lightly rolling vertically in one downward direction to create an even finish.

Work to a continuous pattern of:

- 1 Cut-in wet & "Deliver" in 3-4 roller width strips.
- 2 "Spread" the strips out evenly.
- 3 "Deliver" a fresh strip to create a "working wet edge".
- 4 "Lay-off" the "spread" area.
- 5 Repeat the pattern keeping the "working wet edge" moving across the wall.

1 Cut-in only an area you can roll into wet

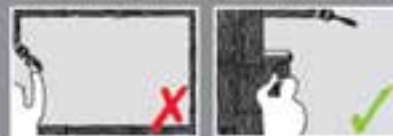

THIN cut-in material by 10%.

2 "Deliver" material to the wall in continuous strips



DO NOT leave gaps to back roll as you may for paint.

3 Spread evenly then "Deliver" a fresh wet edge strip



Backroll to spread and even out.
TIP: Applying a fresh edge strip ahead of your work before laying-off helps keep it wet edge in warmer weather or on larger areas.

4 Finishing (Laying-off)



Empty the roller and lay-off in new vertical direction downwards.
TIP: Working with a partner so one person applies and the other finishes helps keep the wet edge moving across the wall. When working with a partner use a long nap roller for fast delivery and a shorter nap to lay-off for best finish.

TIPS & TOOLS

PROFESSIONAL

heavy duty roller frame and pole. High build coatings require more precise application of pressure to even out the thicker application.



CORRECT

selection of roller sleeve. Texture Roller Sleeves can vary in coil size and firmness according to batch, their age and how they are stored. It is best to check and ensure you have a consistent supply of sleeves to complete the full project.

Ensure you "empty" the roller to lay-off or apply with a partner using a shorter nap roller to finish. If you can see lines or roller pattern wet it won't shrink back like paint.

WET cut-in only an area you can roll into whilst still wet. Thick dry cutting-in will show. Critically important in 1 coat applications.

TEAM the job. Working with a partner, one delivering, one laying-off produces the best results. Dependent on the size of wall and access, two or more people may be needed to make sure that there is a continuous application process across the entire wall.

PLAN applications in the cool of the day or in shade. This is critically important on larger walls. In hot and/or windy conditions, the addition of Hot Weather Thinner at the rate of up to 300ml per 1.5L will assist. In cold conditions the thicker application and heavy atmosphere requires more time and/or improved air movement to assist drying.

ENSURE there is sufficient stock of tinted topcoat material from a single tint lot to cover the full elevation or box multiple lots to ensure colour uniformity.

Duspec	AcraTex 3 Coat AcraShield Coating System for CSR Hebel PowerPattern	Prepared By	Ian Schultz	Page 4 of 5
Duspec No	AU_SA15509-2	Issue No	2	
	Date	01.04.20	Approved By	Ian Schultz

DISCLAIMER:

Any advice, recommendation, information, assistance or service provided by any of the divisions of DuluxGroup Products in relation to goods manufactured by it or their use and application is given in good faith and is believed by DuluxGroup to be appropriate and reliable. However, any advice, recommendation, information, assistance or service provided by DuluxGroup is provided without liability or responsibility PROVIDED THAT the foregoing shall not exclude, limit, restrict or modify the right entitlements and remedies conferred upon any person or the liabilities imposed upon DuluxGroup by any condition or warranty implied by Commonwealth, State or Territory Act or ordinance void or prohibiting such exclusion limitation or modification. Coating systems can be expected to perform as indicated on the Duspec Spec Sheet so long as applications and application procedures of the individual products are followed as recommended on the appropriate Product data Sheet. The data provided within the Duspec system is correct at the time of publication, however it is the responsibility of those using this information to check that it is current prior to specifying or using any of these coating systems. This specification should be read in conjunction with the Product Datasheets specified within this document.

"Dulux" "Berger" "Berger Gold Label" "Hadrian" "Walpamur" "Levene" "AcraTex" are registered trademarks of DuluxGroup Pty Ltd ABN . 67 000 049 427



Important Notes:

It is recommended that the Applicator prepare a reference site sample for approval of the Project Superintendent demonstrating the finish relative to the actual project substrate installed and site conditions.

Coatings must be applied in full accordance with relative product Technical, Application data sheets.

Refer to Material Safety Data Sheet for safe handling information

This specification is to be read in conjunction with DULUX product data and application sheets and product Label detail.

Hebel panel must be installed flush and level otherwise steps across joints will be evident as the routed system design does not allow for making good of panel mis-alignment.

For highest level of surface finish, a trowel applied skimcoat of AcraPatch Smooth is recommended prior to application of coatings.

Practical spreading rates will vary from quoted theoretical figures depending on substrate porosity, alignment, surface roughness, alignment, overspray losses, application methods and environmental conditions (e.g. wind).

All preparation and painting must conform to AS2311: The Painting of Buildings

Plan for application on shaded surfaces, avoid hot windy condition or where rain is likely.

Do not apply products in direct sunlight or if the Relative Humidity is above 85% or temperature is within 3°C of Dew Point or where the surface temperature is greater than 30°C or below 10°C, or likely to fall below 10°C during the application or drying period. Allow longer times under cool, moist, or still conditions and or when applied at high film builds. Protect from dew, rain and frost for 48 hours when apply at the recommended spread rate.

Avoid application in hot, windy conditions or on hot surfaces cool the surface by hosing with water and paint the cool damp surface.

When using Bright Reds, Oranges, Blues and Yellows or where very light colours are applied over highly contrasting colours an extra coat maybe required. Application techniques should be adjusted to achieve the recommended DFT and finishing standard.

To avoid "Picture Framing" use only a 'wet on wet' cutting-in & coating technique incorporating masking taping of the perimeter of the application section.

COLOUR - Dark colours give rise to higher surface temperatures that may cause addition thermal stress and cooling demand to the building envelope and/ or require extra engineering considerations. Colours with a LRV greater than 35% are recommended for panellised construction.

LOCATION - The coastal area is considered a marine environment and as such salt potentially can shorten the life of the coating systems. Care needs to be taken to wash down all areas twice. Once to remove surface contaminants and raise salts to the surface and then secondly to remove these salts. Due to the locality, Weather conditions and lag time between applications of the coating system it may require the need to wash again, between coats.

GLANCING LIGHT - Joints and panel deformation may be more evident under glancing light, casting visible shadows of the minute and uneven projections of the joints. Such Glancing light is light that is nearly parallel to the surface of the wall and casts visible shadows and uneven projections of the joints. Imperfections seen and/or highlighted in critical glancing light conditions are not considered product or application defects and as such are outside the control / scope of this specification. Refer www.dulux.com.au/applicator/technical-advice/preparation/glancing-light

MAINTANENCE - The exterior texture coatings should be cleaned on a regular basis relative to conditions. Removal of surface contaminants will help maintain overall aesthetics and preserve your AcraTex Texture coating system. Fungi and Algae can exist on virtually any surface (even glass) provided the right conditions for growth are met and visible growth on painted surfaces is typically caused by contaminants on the surface together with the presence of high enough levels of moisture to support growth. Agents in paints that restrict mould growth become ineffective where they cannot "touch" the growth source (eg where growth emanates from deposits on the film). Refer : www.dulux.com.au/content/dam/dulux/trade/pdfs/roofingcaremaintenanceguide201411.pdf

SURFACTANT LEACHING FROM EXTERIOR WATER-BASED COATINGS: Occasionally amber, clear or white spots/streaks are seen on a newly painted surface within the first few weeks after application. They usually appear after light rain or overnight dew and generally located in sheltered areas or areas with limited sun exposure. Under normal conditions surfactant contained in the tinted paint colour is slowly leached to the surface and washed away by rain leaving no trace and is a normal part of drying of any exterior water-based paint. Under certain atmospheric conditions and these surfactants leach or migrate to the paint surface, is concentrated forms and leaves clear or white deposits upon drying. These conditions include cool or humid weather or painting cold substrate and in most cases these marks on the wall surfaces are more noticeable on dark colours, such as browns or dark greens, etc. The clear/white surfactants that have migrated to the wall surface areas will cause no down grading nor performance changes or long term durability concerns of the paint films integrity and unfortunately have become an appearance issue instead. They easily removed from the paint film within a week or so of their appearance by washing with warm water & commercial grade detergent or via Nifti or Spray'n'Wipe followed by rinsing with fresh clean water. Under severe conditions they may reappear once or twice until the surfactant has been removed. It will be less noticeable each time and can be removed in the same manner as before. Refer http://www.dulux.com.au/pdf/tech-advice/DLX_TECH_Leaching.pdf

WARRANTY - A DULUX warranty can only be provided when the AcraTex system is applied by a DULUX AcraTex trained applicator, according to specification at the specified spreading rates and to the surface preparation details described in the DULUX AcraTex Specification Manual.

The dynamics of the substrate is outside the control of Dulux Australia and as such joint deformation or cracking is excluded from warranty terms. Refer warranty document for full terms and conditions.

When using this specification, the Installer shall maintain adequate records of proof of purchase and use of Dulux AcraTex Products

Duspec	AcraTex 3 Coat AcraShield Coating System for CSR Hebel PowerPattern				Prepared By	Ian Schultz	Page 5 of 5
Duspec No	AU_SA15509-2	Issue No	2	Date	01.04.20	Approved By	

DISCLAIMER:
 Any advice, recommendation, information, assistance or service provided by any of the divisions of DuluxGroup Products in relation to goods manufactured by it or their use and application is given in good faith and is believed by DuluxGroup to be appropriate and reliable. However, any advice, recommendation, information, assistance or service provided by DuluxGroup is provided without liability or responsibility PROVIDED THAT the foregoing shall not exclude, limit, restrict or modify the right entitlements and remedies conferred upon any person or the liabilities imposed upon DuluxGroup by any condition or warranty implied by Commonwealth, State or Territory Act or ordinance void or prohibiting such exclusion limitation or modification. Coating systems can be expected to perform as indicated on the Duspec Spec Sheet so long as applications and application procedures of the individual products are followed as recommended on the appropriate Product data Sheet
 The data provided within the Duspec system is correct at the time of publication, however it is the responsibility of those using this information to check that it is current prior to specifying or using any of these coating systems. This specification should be read in conjunction with the Product Datasheets specified within this document.
 "Dulux" "Berger" "Berger Gold Label" "Hadrian" "Walpamur" "Levene" "AcraTex" are registered trademarks of DuluxGroup Pty Ltd ABN . 67 000 049 727

APPENDIX C: ROCKCOTE COATING SYSTEM FOR CSR HEBEL POWERPATTERN



Specification ID 201008-114306

HEBEL POWERPATTERN - LINEAR - ARMOUR FLEX

Application over: Hebel 75mm PowerPattern

Usage location: External: Multi-Storey Wall(s)

Surface preparation

Substrate must be clean and free of dust, dirt, oil, salt, mould or any other contamination. Patch any deep holes or imperfections with ROCKCOTE Quick Render Fibre Reinforced.

ROCKCOTE Rockbond 27 must be applied to the surface prior to the application of Step 1 to control absorption, improve adhesion, minimise joint grinning and allow a greater working time.

The moisture content in the substrate must be below 15% WME (Wood Moisture Equivalent) prior to and during the application of the specified ROCKCOTE Coating System.

Important: These systems are dependent on correct and straight installation of the cladding and the level of finish required. If walls require straightening, contact your ROCKCOTE representative for a custom solution.

ROCKCOTE recommends that on large broad wall areas where critical light is an issue, ROCKCOTE Masonry Primer Hi Op be applied prior to the application of ROCKCOTE Armour Flex to ensure uniform coverage and colour consistency.

It is crucial to the success of this system that Armour Flex is applied to the specified film build in order to achieve the required crack bridging capabilities.

Success of coating system is dependent on the patching of panels being carried out to a satisfactory standard prior to the application of the specified ROCKCOTE system. Patches may be visible through texture if poor patching techniques are used.

The substrate must be installed as per manufacturer's guidelines and specifications, this includes the installation of appropriate expansion, control, articulation and movement joints (hereafter referred to as relief joints). Refer to the substrate manufacturers installation manuals and guidelines for placement details of the relief joints. It is the responsibility of the Builder or Main Contractor to ensure all relief joints are installed as per the appropriate substrate manufacturers recommendations or the relevant Australian Standards, prior to the commencement of the coating application. It is the applicators responsibility that all coatings being applied do not impede or breach the relief joints.

Please read all relevant Technical Data Sheets & Safety Data Sheets prior to product use.

STEP 1

Masonry Primer Hi Op



Tinted

Application method:	Brush or Long Nap Roller
Spreading rate:	6m ² /ltr
Drying time:	2 hours

STEP 2

Armour Flex



Application method:	Long Nap Roller
Spreading rate:	3m ² /ltr
Dry coating thickness:	160 microns
Drying time:	6-8 Hours

STEP 3

Armour Flex



Application method:	Long Nap Roller
Spreading rate:	3m ² /ltr
Dry coating thickness:	160 microns
Drying time:	6-8 Hours

Warranty information

The above specification is eligible for a 10 year system warranty when applied in accordance with the relevant technical specifications. ROCKCOTE warrants all its coatings and coatings systems when applied in accordance with the relevant technical specifications. This warranty not only ensures the client's protection but also ROCKCOTE's ongoing commitment to quality.



CSR HEBEL

Triniti 3, 39 Delhi Road
North Ryde NSW 2113, Australia
Telephone +61 2 9235 8000

Health & safety

Information on any known health risks of our products and how to handle them safely is on product packaging and / or the accompanying documentation.

Additional information is listed in the Safety Data Sheet (SDS). To obtain a copy of a SDS, download from www.hebel.com.au. Contractors are required by law to perform their own risk assessments before undertaking work.

Performance & certification

Hebel® products and systems are developed in Australia by CSR Building Products. ABN. 55 008 631 356. It is a manufacturer and supplier of Hebel Autoclaved Aerated Concrete (AAC) products. Because it is a manufacturer and supplier only, CSR does not employ people qualified as Accredited or Principal Certifiers.

CSR is therefore unable to provide Construction Compliance Certificates or Statements of Compliance. CSR conducts appropriate testing of its products and systems to determine performance levels. These include structural, fire and acoustic tests. Testing is conducted and certified by appropriate specialists in these fields. When using Hebel products and systems in specific projects, such specialists should be consulted to ensure compliance with the Building Code of Australia and relevant Australian Standards.

Disclaimer

Information presented in this document is supplied in good faith and to the best of our knowledge at the time of preparation. Products are subject to natural variation as part of the manufacturing process and may vary from actual product in regard to colour and surface finish. Selected imagery has been computer generated and may also vary from actual product. The provision of this information should not be construed as a recommendation to use any of our products in violation of any patent rights or in breach of any statute or regulation. Users are advised to make their own determination as to the suitability of this information in relation to their particular purpose or specific circumstances. Since the information contained in this document may be applied under conditions beyond our control, no responsibility can be accepted by Hebel, or its staff for any loss or damage caused by any person acting or refraining from action as a result of misuse of this information.

Other

The design of a wall, floor or fence system requires the services of professional consultants. This document has been prepared as a source of information to provide general guidance to those consultants – and in no way replaces the services of the professional consultant and relevant engineers designing the project.

No liability can therefore be accepted by CSR or other parties for the use of this document. Hebel products and systems undergo constant research and development to integrate new technology and reflect ongoing performance enhancement.

Hebel systems are constantly reviewed so as to reflect any changes in legislative building requirements and or general developments in common building practice, due to our commitment to continual development and improving our building systems.

We advise that all users of this document should regularly check that this document is current, and they are applying our latest design information.

The latest editions of our documents are available on our website:

www.hebel.com.au

Hebel® is a registered trademark of the Xella group. CSR Building Products Ltd is an exclusive licensee of Xella. CSR Hebel is a business of CSR Building Products Ltd ABN 55 008 631 356.

PowerPattern®, PowerProfile® and PowerPanel® are registered trademarks of CSR Building Products Limited.

THE BETTER WAY TO BUILD

Hebel is a quality building product, and is backed by CSR Building Products Limited.

For more information visit our website:

www.hebel.com.au

For sales enquiries or further information, please telephone us from anywhere in Australia:

1300 369 448



Houses and Low Rise Multi Residential PowerPanelXL External Walls

DESIGN AND
INSTALLATION GUIDE

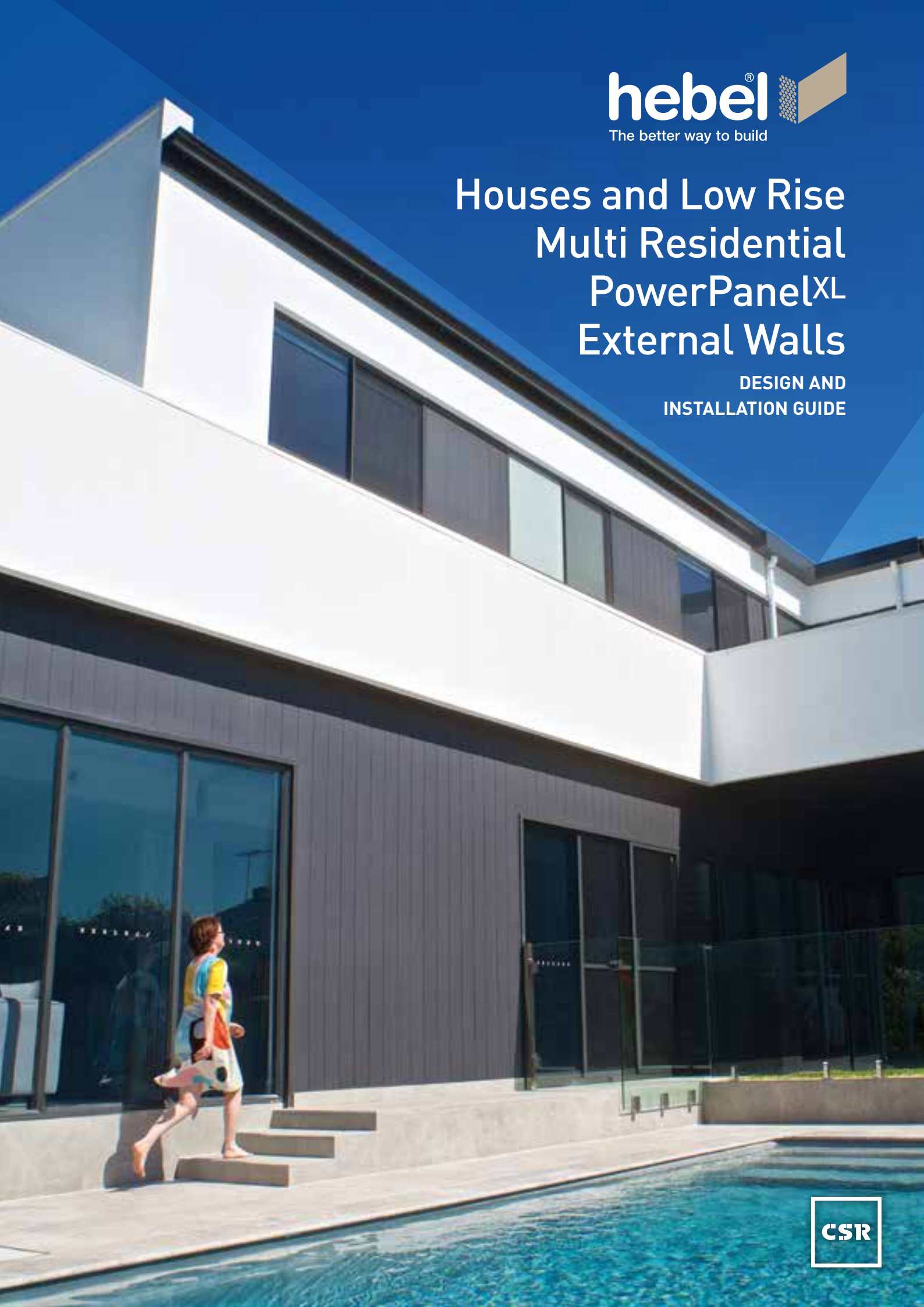

CONTENTS

This Design and Installation Guide has been prepared as a source of information to provide general guidance to consultants – and in no way replaces the services of the professional consultant and relevant engineers designing the project.

It is the responsibility of the architectural designer and engineering parties to ensure that the details in this Design and Installation Guide are appropriate for the intended application.

The recommendations of this guide are formulated along the lines of good building practice, but are not intended to be an exhaustive statement of all relevant data.

Introduction	1
1. Design and selection details	4
1.1 Designing an external wall using Hebel PowerPanel ^{XL}	4
1.2 Structural provisions	5
1.3 Design & detailing considerations	10
1.4 System components	12
2. System performance	14
2.1 Durability	14
2.2 Fire resistance performance	16
2.3 Energy efficiency	17
2.4 Sound transmission and insulation	21
2.5 Coating requirements	22
2.6 Weatherproofing	23
3. Installation detail	24
3.1 Hebel PowerPanel ^{XL} installation sequence	24
3.2 Tools and equipment for construction	25
3.3 Installation of services	25
3.4 External Aluminium render bead	25
3.5 Construction details – overview	26
3.6 Construction details	28
4. Handling, storage and responsibility	49
4.1 Delivery and storage	50
4.2 Panel handling	51
4.3 Design, detailing and performance responsibilities	53
Appendices	54
Appendix A: Hebel PowerPanel ^{XL} material properties	54
Appendix B: PowerPanel ^{XL} external wall system descriptions	55



Disclaimer: The photographs of houses included in this guide, while built from Hebel AAC panels, may not be constructed with the PowerPanel^{XL} system.

WHY HEBEL® SYSTEMS ARE A BETTER WAY TO DESIGN AND BUILD

Whether you're a developer, architect, designer, builder or wall installer, Hebel wall systems deliver exceptional advantages in terms of performance, quality, speed, efficiency, risk minimisation and sustainability values.

Creating high performance buildings using Hebel PowerPanelXL

At the heart of the Hebel external wall system for houses and low-rise multi-residential projects is the Hebel PowerPanelXL - a 75mm thick steel reinforced panel made from autoclaved aerated concrete (AAC).

Developed and warranted by CSR, the Hebel PowerPanelXL can reduce heating and cooling loads on buildings and is non-combustible. It can be produced to the size needed, is easily cut, makes construction fast and efficient, creates minimal waste and is a better choice for the environment compared with concrete or brick.

As with all Hebel reinforced panel products, PowerPanelXL conforms to the Australian Standard for Reinforced Autoclaved Concrete (AAC), AS 5146.

Construction speed and efficiency

The Hebel PowerPanelXL External Wall System speeds up the build process at the same time as delivering a superior finished product – a key reason why developers, builders and owner / builders choose Hebel. For instance, one standard Hebel panel is the equivalent of 75 traditional bricks, which means the walls of a 150m² home can go up in as little as three days when installed by experienced Hebel installers.

Minimising risk

Hebel wall systems provide a solid foundation for risk minimisation in design and construction. They are tested, well proven and designed to achieve NCC fire and thermal compliance easily. Combining the non-combustible property of PowerPanelXL with advanced system designs, CSR Hebel delivers high value cost effective solutions that significantly reduce risk points in construction.

Gaining high sustainability values

Hebel AAC is a durable inert product, made from raw materials in a process that minimises embodied energy. The low bulk density of Hebel AAC means less than a quarter of the resources in raw materials are used in its production than for concrete and bricks.

Waste in production is reduced through extensive recycling. Production waste, slurry and even the steam generated are all recycled back into the manufacturing process while waste steel and oil are recycled off site. Even the non-toxic citrus

based solvents used for cleaning are recycled. Onsite the combination of panel sizes designed to suit standard building modules and the ease of working with standard power tools means there is very little waste. This goes a step further when panels are made-to-order. Altogether, Hebel is one of the most environmentally responsible building materials for wall system construction.

Leveraging the exceptional value-add of Hebel systems

Quite simply the Hebel PowerPanelXL External Wall System for houses and low rise multi-residential projects delivers a holistic solution that no other systems can match. It benefits all stakeholders in the project lifecycle through its role in value-adding to the project's quality, design and construction efficiency, risk minimisation and cost and time certainty.



75mm steel reinforced Hebel PowerPanelXL. For fast construction with minimised waste, 600mm wide panels can be in ordered in stock lengths of 2400, 2550, 2700, 2800, 2850, 3000 and 3300mm.

Typical home construction application

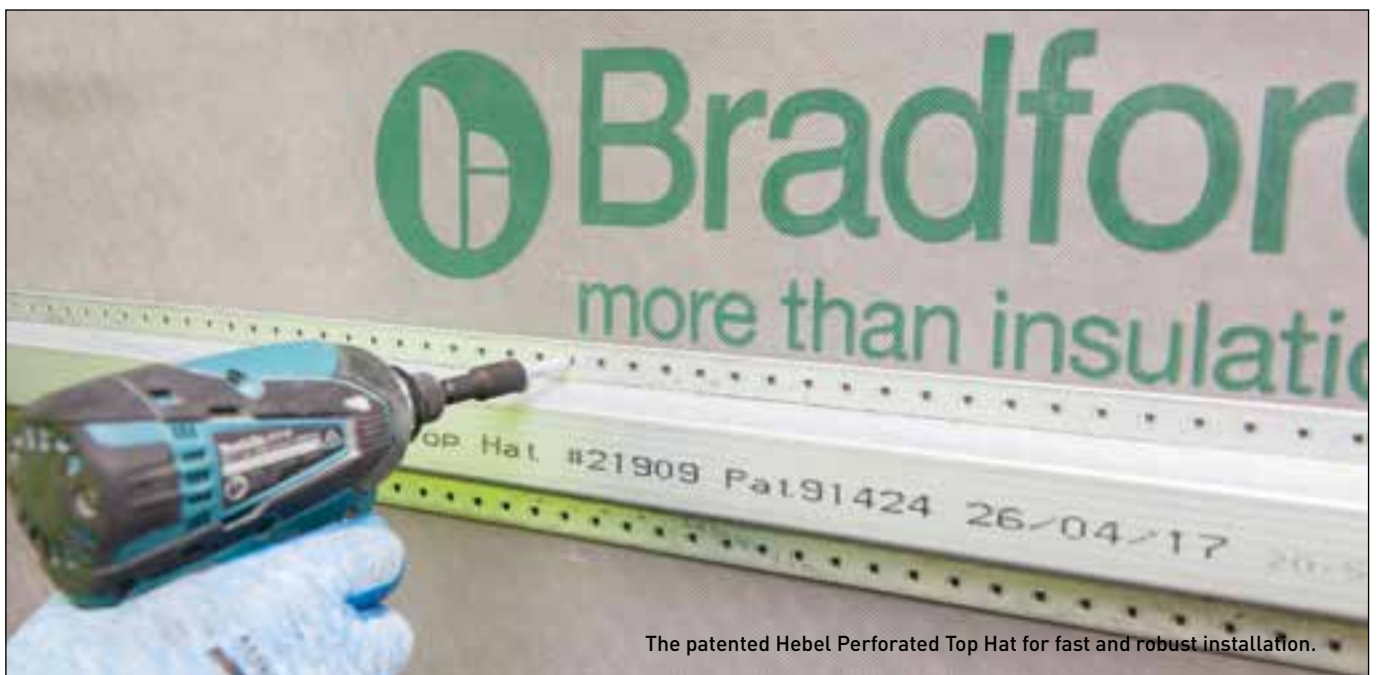
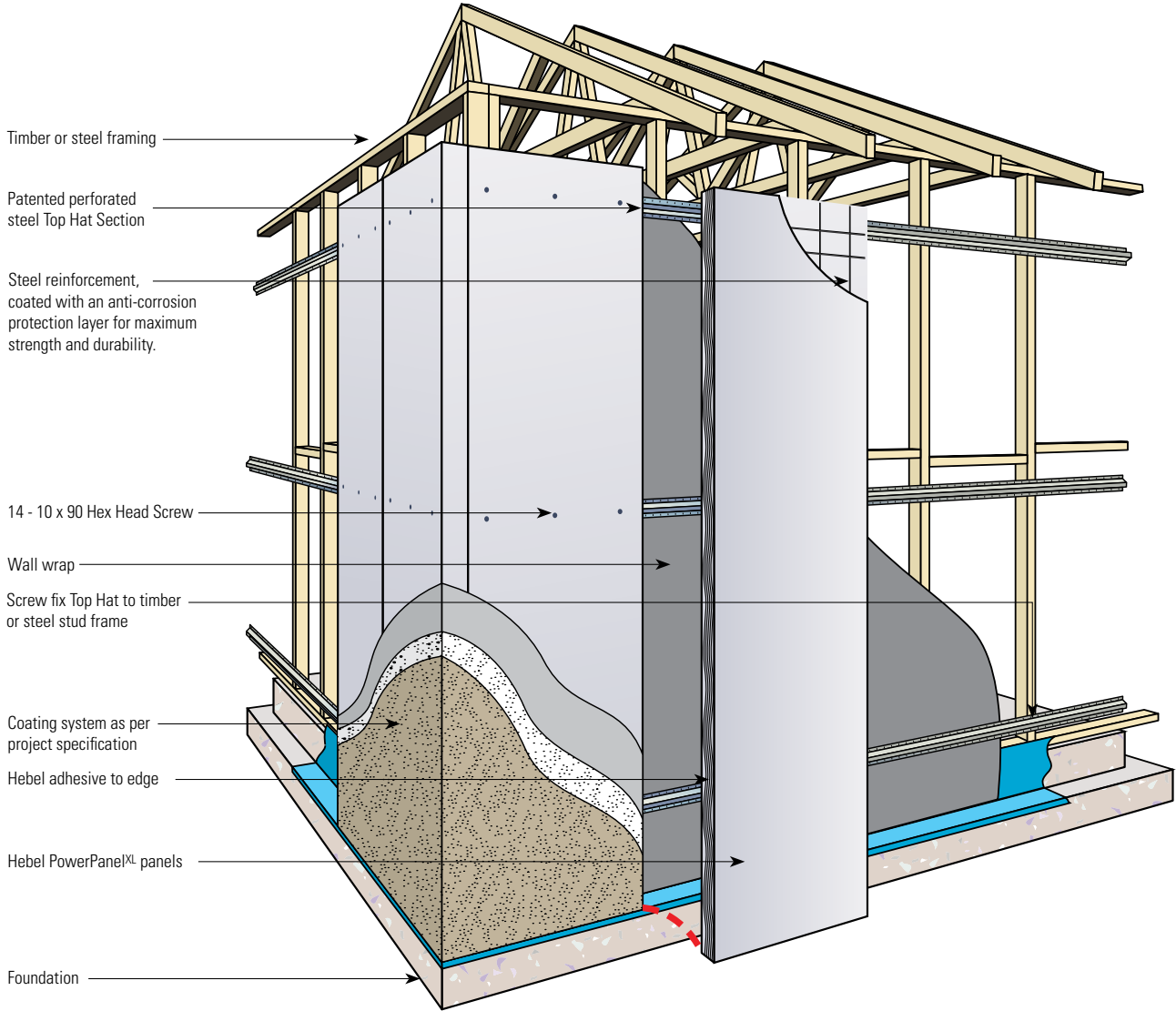

BENEFITS OF BUILDING WITH HEBEL



STRONG AND SOLID

Hebel panels are high-performance building products made from autoclaved aerated concrete (AAC) containing steel reinforcement for added strength, with an anti-corrosion layer on the steel for maximum durability.



ENERGY EFFICIENT

Hebel panels have superior insulation qualities compared to brick and concrete. Tests have shown a house built with Hebel PowerPanel^{XL} performs better than brick veneer in terms of both heating and cooling. This can save the homeowner in heating and cooling energy costs.



QUALITY AND SPEED

Building with Hebel can mean faster construction times, without sacrificing on quality. One standard Hebel panel is the equivalent of 75 traditional bricks, which means the external walls of a 150m² home can go up in just 3 days when installed by experienced Hebel installers. A high quality building material, Hebel provides a great solution in terms of speed and ease of construction which is why it is increasingly becoming the preferred choice of builders and developers.



ECO-FRIENDLY

Independent testing shows that overall, Hebel has a 30% lower environmental impact than concrete or brick veneer. Hebel panels use 60% less embodied energy and produce 55% less greenhouse emissions compared to concrete or brick veneer, making it a more sustainable, environmentally friendly choice of building material.



NOISE REDUCTION

A Hebel home is a quiet one. Building your home in Hebel can significantly reduce the noise transmission between rooms, and when used for floors, can reduce sound transference between levels as well. Compared to polystyrene and many fibre cement substrates, use of Hebel for external walls reduces noise from external sources like traffic, meaning more peace and quiet.



FIRE RESISTANT

Hebel is renowned for its fire resistant properties, and is a non-combustible building material. Hebel systems have been tested by the CSIRO and are proven to achieve Fire Resistance Levels (FRLs) of 60 minutes through to 240 minutes – as well as meeting or exceeding the requirements for all six Bushfire Attack Level (BAL) categories. This makes it an ideal choice in bushfire zones.



PROVEN

CSR Hebel is the only manufacturer of AAC in Australia. With over 25 years of experience in developing, testing and producing AAC you can be assured you're getting high quality products and systems and unmatched technical expertise with Hebel.

1.1 DESIGNING AN EXTERNAL WALL USING HEBEL POWERPANEL^{XL}

DESIGN PROCESS

This section outlines the design process for determining the adequacy of Hebel PowerPanel^{XL} panel.

- STEP 1** Determine the wind category, stud framing layout and panel height requirements.
- STEP 2** Design Criteria. Where required identify the National Construction Code (NCC) Performance Requirements:
 - Fire Resistance Level (FRL).
 - Sound insulation performance (R_w values).
 - Energy efficiency (R-Value).
- STEP 3** The table below can be used to select a type, spacing and quantity of top hats and fixings to suit requirements.
- STEP 4** Select insulation and/or sarking material to suit energy efficiency and condensation requirements.
- STEP 5** Check adequacy of sound insulation and fire resistance level.
- STEP 6** Complete detailed design and documentation.

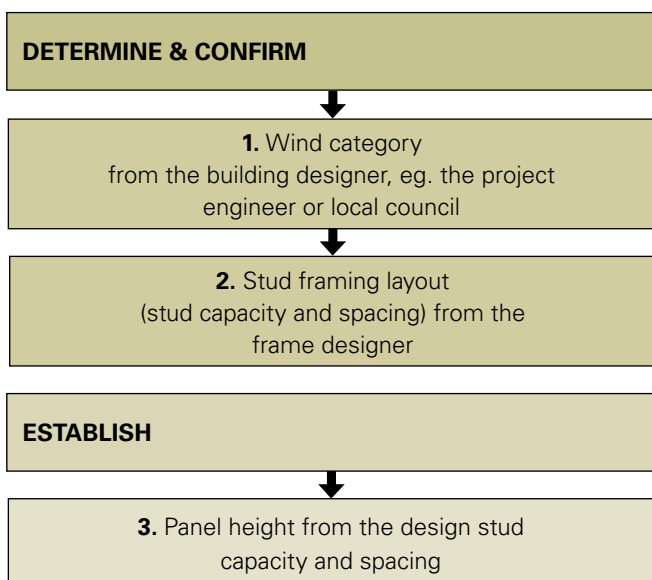

Table 1.1.1 Design process referencing

Determine	Table
No. of top hats	1.2.1 & 1.2.4
Max. stud spacing	1.2.1–1.2.5
No. of screws	1.2.2, 1.2.3 & 1.2.5
Corner effects	1.2.1–1.2.5
Control joint layout	Refer to control joints in construction details section

COMPLIANCE WITH THE NATIONAL CONSTRUCTION CODE OF AUSTRALIA (NCC)

All building solutions such as walls, floors, ceilings, etc. must comply with the regulations outlined in the NCC or other authority.

The NCC is a performance based document, and is available in two volumes which align with two groups of ‘Class of Building’:

- Volume 1 – Class 2 to Class 9 Buildings; and
- Volume 2 – Class 1 & Class 10 Buildings – Housing Provisions.

Each volume presents Regulatory Performance Requirements for different Building Solutions for various classes of buildings and performance provisions.

These Performance Provisions include: Structure; Fire Resistance; Damp & Weatherproofing; Sound Transmission & Insulation; and Energy Efficiency.

This guide presents tables, charts and information necessary to assist in the design of a system incorporating Hebel PowerPanel^{XL} that complies with the Performance Requirements of the NCC. The designer must check the adequacy of the building solution for Performance Requirements outlined by the appropriate authority.

COMPLIANCE WITH AS 5146 REINFORCED AUTOCLAVED AERATED CONCRETE

All Hebel reinforced panel products conform with the Australian Standard for Reinforced Autoclaved Aerated Concrete (AAC), AS 5146.

The set of AS 5146 standards comprise of 3 parts:

- AS 5146 Part 1 – Structures
- AS 5146 Part 2 – Design
- AS 5146 Part 3 – Construction

These Standards are referenced in the Building Code of Australia making compliant AAC products Deemed-to-Satisfy (DTS) building materials.

AS 5146.3 – Construction, Section 4 contains details for 75mm reinforced AAC external walls in houses and low rise multi residential buildings, considered a DTS building system.

This provides the endorsement and confidence to regulatory and building certification bodies that the Hebel PowerPanel^{XL} External Wall System is a NCC compliant construction system.

1.2 STRUCTURAL PROVISIONS

OVERVIEW

The Hebel PowerPanel^{XL} External Wall System consists of Hebel PowerPanel^{XL} panels secured to the framing via horizontal steel top hats. This section provides the basic information on the selection of top hat spacings for a given stud spacing and wind category, as well as considerations to assist the designer in determining the appropriate wall configuration.

The design information presented in Tables 1.2.1 to 1.2.5 has been determined for 24mm and 35mm Hebel Perforated Top Hat section.

Minimum performance requirements for the metal studs, Hebel Perforated Top Hats, fixings and Hebel PowerPanel^{XL} have been provided to assist the designer.

IMPORTANT: The design and approval of the structural framing (cold-formed steel or timber) is to be provided by the framing product manufacturer and/or project engineer.

PRINCIPLES OF DESIGN

The principles on which the design is based include:

- a) The lateral wind loads applied to the panels are transferred into the horizontal top hats, then to the stud frame, which should be designed in accordance with the relevant Australian Standards for the imposed loads. The frame should be designed for all bracing and hold-down requirements.
- b) The design of the stud frame shall consider the weight of the suspended panels (such as the upper storey of two-storey construction).
- c) The system is not considered as cavity construction, as the Top Hat clearly bridges the cavity, hence the details show the necessity of sealing the windows and door frames, as well as applying a water resistant external coating.
- d) The system specifications vary with wind load. The notation used in AS 1684 Residential Timber Framed Construction has been adopted.
- e) The localised effects of wind around corners of buildings have been considered in the design and included in the tables. The extent of this effect is discussed towards the end of this section.

Design Procedure

Design procedures for the verification of wall systems consisting of Hebel Autoclaved Aerated Concrete (AAC) PowerPanel^{XL} panels generally follow the design principles outlined in Australian Standard AS 3600 – Concrete Structures for strength and serviceability design, with the exception of cover requirements for durability and development length for reinforcement.

The serviceability design of the Hebel PowerPanel^{XL} panels has been carried out using the Transformed Section Theory, as detailed in the text book, 'Reinforced Concrete' by Warner, Rangan and Hall (Longman Cheshire). The load carrying capacity of the Hebel PowerPanel^{XL} panels is influenced by several factors, such as:

- Imposed action (wind).
- Lateral stiffness of the supporting structure, lightweight structural, cold-formed steel framing.
 - Stud size and spacings.
 - Deflection limit.
- Height of the wall.
- Number and spacing of the top hats.
- Number of screw fixings considered effective.

Criteria for corner panels

Due to the increase of wind load around the corners of buildings, extra top hats and screws may be necessary (N3 and greater) for a distance of 1200mm in each direction from the corner.

Tables 1.2.1 to 1.2.5 identify the installation criteria in these areas in the columns titled 'Panel Location – Corner'.

Earthquake loads

Earthquake loading has not been considered in this design guide.

DESIGN TABLES

This section presents tables to assist the designer in the selection of the number of top hats and number of screws for securing the Hebel PowerPanel^{XL} panels to the framing for a given wind category.

NOTES:

1. The wind category is to be used as a guide. The designer should check the project wind pressure against the values given in the tables.
2. Panels not tested for impact loading from windborne debris in Regions C and D as per AS1170.2. Building designer should allow for internal pressures resulting from dominant openings.

STUD FRAME – STEEL OR TIMBER

The stud frame shall be designed by the stud manufacturer or appropriate project engineer. Hebel PowerPanel^{XL} panels are a steel reinforced AAC product and the support structure should be designed to provide sufficient stiffness.

The steel stud frame shall be designed and constructed in accordance with AS 3623 and AS/NZS 4600 (NCC Performance Requirement).

The timber stud frame shall be designed and constructed in accordance with AS 1684.

HEBEL PERFORATED TOP HAT

Hebel Perforated Top Hats in galvanised steel are provided in nominal widths of 24mm and 35mm and have been designed and constructed in accordance with AS 3623 and AS/NZS 4600 (NCC Performance Requirement). The following tables are based on the 24mm and 35mm Hebel Perforated Top Hat section:

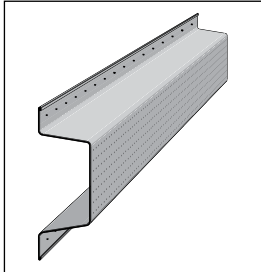

24mm Perforated Steel Top Hat section properties:

- Cold-formed perforated steel top hats
- Minimum thickness 0.42mm BMT
- Minimum yield strength 550MPa (zincalume)
- Coating class AZ150 (see Durability).

35mm Perforated Steel Top Hat section properties:

- Cold-formed perforated steel top hats
- Minimum thickness 0.55mm BMT
- Minimum yield strength 270MPa (Galvabond)
- Coating class Z275 (see Durability).

PANELS SUPPORTED AT BASE

Table 1.2.1 Number of top hats – panel supported at base (such as slab edge or shelf angle)

Wind category	Ultimate wind pressure (kPa)		Stud spacing (mm)	Number of top hats per panel							
	Away from corners	Within 1200mm of corners		Panel length (mm)							
				≤ 2400		≤ 2700		≤ 3000		≤ 3300	
				Panel location		Panel location		Panel location		Panel location	
				Typical	Corner	Typical	Corner	Typical	Corner	Typical	Corner
N2	0.67/-0.62	-1.25	600	3	3	3	3	4	4	4	4
N3,C1	1.05/-0.98	-1.95	600	3	4	3	4	4	4*	4	5
N3,C1	1.05/-0.98	-1.95	450	3	3	3	3	4	4	4	4
N4,C2	1.56/-1.45	-2.90	450	3	4	3	5	4	5	4	6
N5,C3	2.30/-2.14	-4.27	450	4	5	5	5	5	6	5	6

* One additional top hat is required when Hebel direct fix clips are used to support top hats.

NOTES:

1. Negative pressure indicates wind suction.
2. All top hats to be spaced evenly, with top and bottom top hats installed 250mm (maximum) from the end of the PowerPanel^{XL}.
3. The bottom top hat may be installed 450mm from the bottom edge of the panel (distance measured from the centre of the top hat) for N2 and N3, C1 wind category, provided the amount of screws are installed as follows. 3 screws per top hat at typical panel locations and 4 screws per top hat at corner panel locations.
4. Additional top hats will be required below all window openings and above openings if a PowerPanel^{XL} or sill block is to be installed in this location.
5. Corner panel location applies to a PowerPanel^{XL} panel within 1200mm of corners.

Table 1.2.2 Number of screws per panel at each top hat location – panel supported at base (such as slab edge or shelf angle)

Wind category	Ultimate wind pressure (kPa)		Stud spacing (mm)	Number of screws per panel per top hat			
	Away from corners	Within 1200mm of corners		Panel location			
				Typical		Corner	
				Top hat location		Top hat location	
				Ends	Middle	Ends	Middle
N2	0.67/-0.62	-1.25	600	2	2	2	2
N3,C1	1.05/-0.98	-1.95	600	2	3	2	3
N3,C1	1.05/-0.98	-1.95	450	2	2	2	3
N4,C2	1.56/-1.45	-2.90	450	2	3	3	3
N5,C3	2.30/-2.14	-4.27	450	2	3	3	4

NOTES:

1. Type of screw used is 14-10x90mm hex head type 17 screw, fixed from outside the building.
2. Corner panel location applies to PowerPanel^{XL} within 1200mm of corners.

PANELS SUSPENDED FROM FRAME

Table 1.2.3 Number of screws per panel at each top hat location – panel suspended at gable ends

Wind category	Ultimate wind pressure (kPa)		Stud spacing (mm)	Number of screws per panel per top hat		Maximum spacing of top hat (mm)	
	Away from corners	Within 1200mm of corners		Panel location		Panel location	
				Typical	Corner	Typical	Corner
N2	0.67/-0.62	-1.25	600	2	3	800	750
N3,C1	1.05/-0.98	-1.95	600	3	4	800	600
N3,C1	1.05/-0.98	-1.95	450	3	4	800	650
N4,C2	1.56/-1.45	-2.90	450	4	4	800	450
N5,C3	2.30/-2.14	-4.27	450	4	4	600	350

NOTES:

1. Top and bottom top hats installed 250mm (maximum) from the end of the PowerPanel^{XL} panel.
2. Top hats to be installed horizontally with panels to span vertically. Number of screws per panel per top hat information is not suitable for soffits or any other areas where the panel is not vertical.
3. Corner panel location applies to PowerPanel^{XL} panels within 1200mm of corners.
4. Type of screw used is 14-10x90mm hex head type 17 screw, fixed from outside the building.

Table 1.2.4 Number of top hats – panel suspended from framing (e.g second storey construction)

Wind category	Ultimate wind pressure (kPa)		Stud spacing (mm)	Number of top hats per panel							
	Away from corners	Within 1200mm of corners		Panel length (mm)							
				≤ 2400		≤ 2700		≤ 3000		≤ 3300	
				Panel location		Panel location		Panel location		Panel location	
Typical	Corner	Typical	Corner	Typical	Corner	Typical	Corner				
N2	0.67/-0.62	-1.25	600	4	4	4	4	4	4	4	4
N3,C1	1.05/-0.98	-1.95	600	4	4	4	4	4	4	4	4*
N3,C1	1.05/-0.98	-1.95	450	4	4	4	4	4	4	4	4
N4,C2	1.56/-1.45	-2.90	450	4	4	4	4*	4	5	4	5*
N5,C3	2.30/-2.14	-4.27	450	4	5	5	6	5	6	5	6

* One additional top hat is required when Hebel direct fix clips are used to support top hats.

NOTES:

1. Negative pressure indicates wind suction.
2. All top hats to be spaced evenly, with top and bottom top hats installed 250mm (maximum) from the end of the PowerPanel^{XL} panel.
3. Additional top hats will be required below all window openings and above openings if a panel or sill block is to be installed in this location.
4. Corner panel location applies to PowerPanel^{XL} panels within 1200mm of corners.

Table 1.2.5 Number of screws per panel at each top hat location – panel suspended from framing (e.g second storey construction)

Wind category	Ultimate wind pressure (kPa)		Stud spacing (mm)	Number of screws per panel per top hat			
	Away from corners	Within 1200mm of corners		Panel location			
				Typical		Corner	
				Top hat location		Top hat location	
Ends	Middle	Ends	Middle				
N2	0.67/-0.62	-1.25	600	2	2	2	3
N3,C1	1.05/-0.98	-1.95	600	2	3	3	4
N3,C1	1.05/-0.98	-1.95	450	2	3	3	4
N4,C2	1.56/-1.45	-2.90	450	2	4	3	4
N5,C3	2.30/-2.14	-4.27	450	2	4	4	4

NOTES:

1. Type of screw used is 14-10x90mm hex head type 17 screw, fixed from outside the building.
2. Corner panel location applies to PowerPanel^{XL} panels within 1200mm of corners.

PANELS FIXED TO DROP EDGE BEAM

Table 1.2.6 Number of top hats per panel - drop edge beam fixing

Wind category	Ultimate wind pressure (kPa)		Fixing spacing of top hat to concrete (mm)	Max. top hat spacing							
	Away from corners	Within 1200mm of corners		Panel length (mm)							
				≤ 2400		≤ 2700		≤ 3000		≤ 3300	
				Panel location		Panel location		Panel location		Panel location	
				Typical	Corner	Typical	Corner	Typical	Corner	Typical	Corner
N2	0.67/-0.62	-1.25	600	900	600	900	600	900	600	900	600
N3, C1	1.05/-0.98	-1.95	600	900	600	900	600	900	450	900	600
N3, C1	1.05/-0.98	-1.95	450	900	450	900	450	900	450	900	450
N4, C2	1.56/-1.45	-2.9	450	600	450	600	450	600	450	600	450
N5, C3	2.30/-2.14	-4.27	450	450	300	450	300	450	300	450	300

NOTES:

1. Top and bottom top hats installed 250mm (maximum) from the end of the PowerPanel^{XL} panel.
2. Maximum end overhang of top hat to be 150mm.
3. Minimum concrete grade is 25MPa.
4. Corner panel location applies to PowerPanel^{XL} panels within 1200mm of corners.
5. Ramset Ramplug DNP08 to be used to fix the top hats to the concrete drop edge beam. Screw selection and installation of fixings must be in accordance to manufacturer's requirements.
6. At each fixing point, two anchors are required. Minimum anchor spacing and minimum concrete edge distance to be 50mm.
7. Screws to fix panel to top hat to be in accordance to table 1.2.2.

FIXINGS

Table 1.2.7 outlines the connection type and requirements for constructing Hebel PowerPanel^{XL} detailed in this design guide.

NOTE: From Table 1.2.7, 14-10x90mm hex head type 17 screws are specified and recommended for fixing the Powerpanel^{XL} panel to top hat sections from the outside of the building. Refer to Hebel Technical Update TU-017 where bugle head screws are desired to be used in lieu of the 14-10x90mm hex head type 17 screws for this connection.

The project engineer or framing manufacturer is responsible for specification of alternative details. The minimum performance requirement of the screw is:

- Minimum screw coating class in accordance with AS 3566: Class 3 (Refer Section 2.1 for Durability).

Zero boundary wall installation

Where access is limited or unavailable for fixing the PowerPanel^{XL} panel to the top hat section from the outside of the building, such as in zero boundary wall installations, then fixing of the panel from the inside of the building using 14-10x65mm hex head type 17 screws is permitted on the basis that one additional screw (to the number of screws noted in Tables 1.2.2, 1.2.3 & 1.2.5 is provided per panel per top hat connection. For more details refer to Figure 3.6.4.2 and Hebel Technical Update TU-018.

Table 1.2.7 Screws types

Type of screw	Application	Socket type
12-11x35mm hex head type 17 screw	Fix top hat to timber frame	5/16" hex mag. socket
10-16x16mm hex head self drilling screw	Fix top hat to steel stud frame (1.2mm BMT max.)	5/16" hex mag. socket
14-10x65mm hex head type 17 screw	Fix PowerPanel ^{XL} to top hat from inside of building (zero boundary application only)	3/8" hex mag. socket
14-10x90mm hex head type 17 screw*	Fix PowerPanel ^{XL} to top hat from outside of building	3/8" hex mag. socket

* The screws fixing the PowerPanel^{XL} panels to top hats are countersunk min. 5mm into the panel and filled with Hebel Adhesive

STRUCTURAL FRAMING DESIGN

The use of Hebel PowerPanel^{XL} in two-storey construction involves a number of design issues that require attention. In conjunction with the following, refer to the Construction Details in Section 3.6.

NOTE: When PowerPanel^{XL} panels are suspended from the stud frame the project engineer shall design the frame to support the weight of the PowerPanel^{XL} panels.

Steel joists or engineered timber joists (≤1% shrinkage)

Lower storey panels are to bear on the slab edge. However, consideration should be given to the sectional size of the lintels over openings on the lower storey. As the details reveal, only a dummy control joint (nominal 10mm packers, backing rod and an external grade acoustic and/or fire rated paintable sealant joint) is required at the horizontal PowerPanel^{XL} junction between the upper and lower panels. The panel support packer should consist of a durable material that will not degrade during the life of the structure.

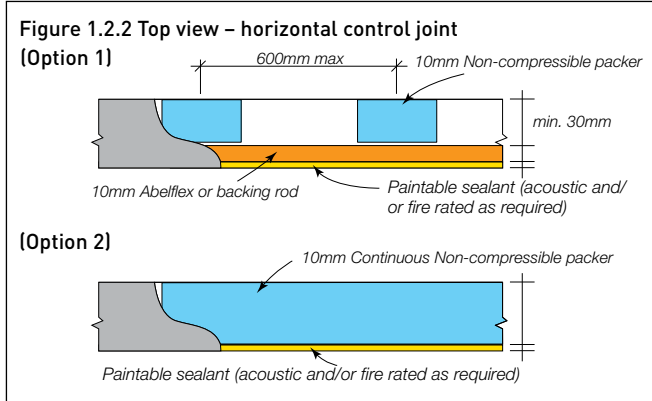
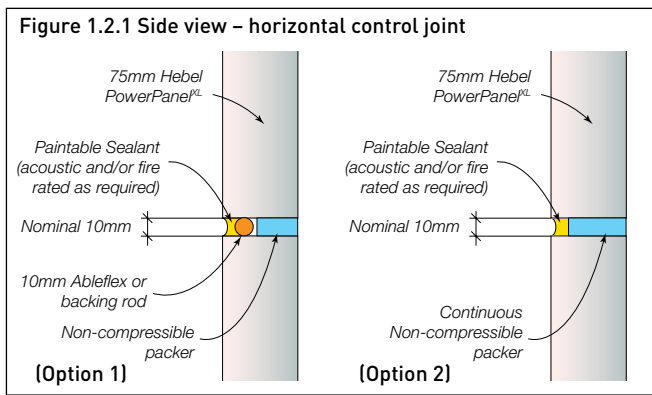

NOTE: Use 10mm wide by 16mm deep CSR Fireseal or Fireblock XT Sealant at vertical and horizontal control joints to achieve FRL of -/120/120 for the wall system. See Section 2.2. Protect CSR Fireseal Sealant from rain until sealant has developed a thick skin. Once cured, CSR Fireseal should be painted over with a compatible external grade acrylic coating i.e. Dulux AcraTex or similar.

Timber frame construction (>1% shrinkage joist).

Movements in the order of 25mm can occur in a two storey timber frame with a timber first floor. The fixing method used in the Hebel PowerPanel^{XL} External Wall System does not allow for this extent of differential movement between the external skin and the timber frame.

The allowances for shrinkage of timber framing in NCC Vol. 2, by providing gaps between framing and masonry, should be adopted as a minimum.

It is therefore recommended that the upper storey PowerPanel^{XL} panels be installed 35mm clear of the lower storey panels. During construction a temporary packer can be used to separate the panels and is then removed after the panels have been fixed. An architectural trim (feature moulding) must be used to hide the horizontal control joint. Contact Hebel Technical Services for further details.

The impact of this construction is to load the lower storey frame with the weight of the upper storey panels. In effect, an extra 44kg/m² (for the weight of the upper panels) is being added to the load already carried by the timber frame. The load approximates 1.05kN/m (2.4m wall height).

To simplify the design implications of this extra load, it is recommended to add an extra 1.4m of tributary width for a 90kg/m² tile roof load (for 2.4m upper wall heights) for the design of the lower storey frame and timber lintels, when using AS 1684. – cyclonic or non-cyclonic areas.

NOTE: Additional considerations should be undertaken for installation of the Hebel PowerPanel^{XL} External Wall System onto copper treated timber including wall framing treated with CCA (Copper Chrome Arsenic). Contact Hebel Technical Services for more information.

Bracing of the building

The walls of the dwelling should be braced using steel cross bracing wherever possible to allow the fixing of the PowerPanel^{XL} panels without the need for additional packing. Ply or sheet bracing should be used on the external wall if the walls are too short for the steel cross bracing (refer AS 1684 – cyclonic or non-cyclonic areas). In this case, the full length of the wall should be sheeted to prevent misalignment of the panels.

Alternatively, localised strips of the sheeting can be fixed to the intermediate studs between the areas of full sheet bracing to maintain the panel alignment. All fixing is only from the outside, except on zero boundary walls. The extent of the bracing should be determined by the frame designer or project engineer.

NOTE: Minimum screw embedment depth into timber frame must be 25mm.

Table 1.2.8 Comparative wall thicknesses (mm)

Wall system	Wall element width			Total width
	Stud	Cavity	Masonry leaf	
Brick veneer	70	40	110	220
Hebel PowerPanel ^{XL}	70	24 – 35*	75	169 – 180*
Brick veneer	90	40	110	240
Hebel PowerPanel ^{XL}	90	24 – 35*	75	189 – 200*

* NOTE: Depending on top hat selection

1.3 DESIGN & DETAILING CONSIDERATIONS

BUILDING SETOUT

The Hebel PowerPanel^{XL} External Wall System is principally designed for modular construction. The full benefit of savings in time and cost will be fully realised when the construction is designed to suit a 300mm module. In principle, thoughtful setout on the drawing board will minimise the site-cutting of the panels, which is time consuming and wasteful compared to the installation of stock PowerPanel^{XL} panels.

External wall height

Typically the external wall height is the distance from the base of the slab step down up to 50mm above the height of the eaves lining.

Window and door heights should also be considered when determining panel layout. Typically a 300mm distance below or above door or window heights is desirable.

Wall length (horizontal dimensions)

Although not as critical as the wall height, the wall length designed to 300mm dimensions will help reduce waste.

TERMITES

It is the builder's responsibility to ensure that all council and NCC requirements are fully adhered to in regard to the design of the house for preventing termite attack. The construction details contained in this guide do not attempt to fully address the issues due to the variation of requirements from state to state. Hebel PowerPanel^{XL} is ideally suited to the exposed edge method of perimeter protection. NCC Vol. 2 deals with termite risk management and the reference code is AS 3660.

FOOTINGS

Footings for Hebel PowerPanel^{XL} should comply with articulated masonry veneer construction as specified in Australian Standard AS 2870. This is a minimum requirement. Local engineering advice should always be sought, especially in areas of highly reactive ground conditions.

MOVEMENT CONTROL JOINTS

During the life cycle of a building, the building and the materials that it is constructed from will move. These movements are due to many factors working together or individually, such as support structure movement (lateral sway or vertical deflection), thermal expansion and contraction and differential movements between materials. This movement, unless relieved or accommodated for, will

induce stress in the materials, which may be relieved in the form of cracking. To accommodate these movements and relieve any induced stresses, which could potentially crack the wall, movement joints need to be installed.

- Control joints are provided to relieve the induced stresses resulting from thermal expansion or contraction of the AAC, or differential movement between the AAC and another material or structure, such as abutting walls or columns of concrete or brickwork. Control joints can delineate coating shrinkage breaks.

Vertical control joints should coincide with control joints in the supporting structure and anywhere that significant structural movement is expected, where the wall abuts a vertical structure, such as an existing building, or adjacent to large openings. Refer to control joints in **construction details section**.

Table 1.3.1 Spacing of vertical control joint based on site classification

Site Class	Vertical control joint spacing
A, S	6
M, M - D	5.5
H1, H1 - D	5
H2, H2 - D	4.5

Notes:

1. Refer to AS2870 for guidance on the site classification.
2. Where building on a site with a class P identification, advice should be sought from a structural engineer. Sites identified as class P can relate to a single or number of soil conditions that may affect the behaviour of the slab (i.e. mine subsidence, varying depths of fill, abnormal moisture conditions etc.) As such, the project structural engineer would normally design the slab according to these site specific features and upon advice from a geotechnical report. From this assessment the engineer can then relate the soil type back to class A, S, M or H type soils based on the extent of settlement/heave (particularly in clay type soils). The spacing of control joints required in the external walls can then be determined based on Table 1.3.1, above. Note: The location of control joints for class E sites should be determined by engineering principles and specified by the project structural engineer.

Important: Where installing Hebel external wall claddings on slab edge rebates for sites that contain saline soils, a clearance between the base of the panel and the finished ground level must be maintained to avoid contact of the panels with these soils. Where the slab edge rebate is rendered, it must be ensured that the DPC under the panel is cut flush with the external face of the panel to form a barrier between the slab edge rebate and the underside of the overhanging section of panel to prevent the rise of salts (from saline soils) through the slab edge render and into the panel.

This guide proposes minimum widths for the movement joints. The project engineer shall determine if the joints are sufficient to accommodate the movement of the specific project building. Typically, the vertical joint is nominally 10mm wide and filled with an appropriate backing rod and flexible sealant.

NOTE: At all control joints, the top hat should be discontinuous to allow for the effective movement of the building at these locations.

A horizontal control joint is required beneath slabs or angles to accommodate any expected deflection. The magnitude of the deflection must be verified by the building designer. Typically, the horizontal joint is nominally 10mm wide and filled with an appropriate external grade acoustic and / or fire rated paintable sealant. External aluminium render beads can be used as an option at horizontal control joints providing neat and consistent finished joints (Refer to Section 3.4).

CONDENSATION

Condensation is a complex problem and can occur under a variety of conditions, not just cold conditions. Literature on this subject is available from CSIRO/BRANZ/ASHRAE and must be consulted when building in areas where condensation is likely to occur.

In these cases, the appropriate use of a sarking as a vapor barrier or as thermal insulation, or both, can be effective in controlling condensation.

PENETRATIONS

Small service penetrations through the panel should allow for differential movement between the panel and the service. All penetrations are a potential source for water ingress and should be sealed with an appropriate acoustic and/or fire rated paintable sealant.

WINDOWS

The builder should also ensure that the reveal size is correct to suit PowerPanelXL. Refer to Table 1.3.1 for recommendations.

The sizes below typically apply to aluminium framed windows. If timber windows are being used similar tolerances and guidelines apply.

Table 1.3.2 Reveal size

Stud size 70mm	
Top hat size	Reveal size**
24mm	100mm*
35mm	115mm
Stud size 90mm	
Top hat size	Reveal size**
24mm	120mm
35mm	135mm

*Reveal sizes may vary from one manufacturer to another.

**Figures shown assume brace board is used on framework.

NOTE: The external sealant in the control joints adjacent to windows must be retuned to the window frame, and sealant installed along the window head, sill and junction of the sides of the window to the panel. No gap should exist between the external sealant and the window frame.

SUPPLEMENTARY CLADDING







Supplementary cladding systems such as weatherboards and lightweight fibre cement may be installed over the top of the Hebel PowerPanelXL External Wall System. For more details please contact Hebel Technical services.



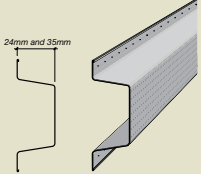





Photo courtesy of Danette Architecture.

1.4 SYSTEM COMPONENTS

The PowerPanelXL External Wall System is a complete system and Hebel stocks many of the products and materials required for your convenience.

Product	Description	Supplied by CSR Hebel																												
Hebel PowerPanelXL	<p>The core component of the Hebel PowerPanelXL External Wall System is the 75mm thick Hebel PowerPanelXL panel. The panel is manufactured in a range of stock sizes as detailed below:</p> <table border="1"> <thead> <tr> <th colspan="3">Panel weight (kg)</th> </tr> <tr> <th>Length (mm)</th> <th>Width (mm)</th> <th>Weight (kg) at 35% M.C.</th> </tr> </thead> <tbody> <tr> <td>2400</td> <td>600</td> <td>58</td> </tr> <tr> <td>2550</td> <td>600</td> <td>62</td> </tr> <tr> <td>2700</td> <td>600</td> <td>66</td> </tr> <tr> <td>2800</td> <td>600</td> <td>68</td> </tr> <tr> <td>2850</td> <td>600</td> <td>69</td> </tr> <tr> <td>3000</td> <td>600</td> <td>73</td> </tr> <tr> <td>3300</td> <td>600</td> <td>80</td> </tr> </tbody> </table> <p>NOTE: 75mm PowerPanel 1200 x 600mm weight 37kg. 75mm PowerPanel 1800 x 600mm weight 56kg.</p>	Panel weight (kg)			Length (mm)	Width (mm)	Weight (kg) at 35% M.C.	2400	600	58	2550	600	62	2700	600	66	2800	600	68	2850	600	69	3000	600	73	3300	600	80	✓	
Panel weight (kg)																														
Length (mm)	Width (mm)	Weight (kg) at 35% M.C.																												
2400	600	58																												
2550	600	62																												
2700	600	66																												
2800	600	68																												
2850	600	69																												
3000	600	73																												
3300	600	80																												
Top Hat	<p>Hebel Perforated Top Hats are used to fix the Hebel PowerPanelXL panel to the structural support framing. There are two nominal widths available: 24mm and 35mm – incorporating perforated flanges for ease of installation on to external wall frame.</p>	✓																												
Fasteners & Fixings	<p>Fixing of top hat to timber stud frame; 12-11x35mm hex head type 17 screw.</p>	✓																												
	<p>Fixing of top hat to steel framing; 10-16x16mm hex head self drilling screw.</p>	✓																												
	<p>Fixing of Hebel PowerPanelXL panels to top hat from inside of buildings 14-10x65mm hex head type 17 screw (zero boundary walls only). Refer to Table 1.2.7.</p>	✓																												
	<p>Fixing of Hebel PowerPanelXL panels to top hat 14-10x90mm hex head type 17 screw.</p>	✓																												
Hebel Direct Fixing Clip	<p>For attaching top hat to structural stud frame (zero boundary application only).</p>	✓																												

Product	Description	Supplied by CSR Hebel	
Hebel Mortar	Hebel Mortar (supplied in 20kg bags) when required is used as a thick bed mortar base to provide a level base for PowerPanel ^{XL} installation as well as providing acoustic and fire protection at the base of the panels.	✓	
Hebel Adhesive	Hebel Adhesive (supplied in 20kg bags) is used for gluing the PowerPanel ^{XL} panels together at vertical and horizontal joints.	✓	
Hebel Patch	Minor chips or damage to PowerPanel ^{XL} panels are to be repaired using Hebel Patch (supplied in 10kg bags).	✓	
Hebel Anti-Corrosion Protection Paint	To coat exposed reinforcement during cutting.	✓	
Hebel Base Sealer	For use when sealing the base of Hebel panels that may come into contact with soil levels (supplied in 5L tubs)	✓	
Hebel External Aluminium Render Bead (Optional)	Hebel External Aluminium Render Bead is used to provide neat and consistent horizontal control joints.	✓	

NOTE: CSR has engineered and tested the PowerPanel^{XL} External Wall System to comply with the NCC and relevant Australian Standards. It cannot guarantee products and accessories not specified by CSR will perform to these standards. The Product Guarantee will only apply if all components used in the system are specified by CSR.

2.1 DURABILITY

OVERVIEW

Durability means the capability of a building or its parts to perform a function over a specified period of time. It is not an inherent property of a material or component. It is the outcome of complex interactions among a number of factors, including:

- The service conditions
- Material characteristics
- Design and detailing
- Workmanship
- Maintenance

(‘ABCB Guideline Document – Durability in buildings: 2003’)

The following sub-sections of the durability topic are written in order to provide general guidelines on how best to provide, enhance and maintain adequate durability of Hebel PowerPanel^{XL} panels.

MAINTENANCE & ENHANCEMENT OF DURABILITY

The durability of the Hebel PowerPanel^{XL} External Wall System can be enhanced by periodic inspection and maintenance. Inspections should include examination of the coatings, flashings and sealants. Paint finishes must be maintained in accordance with the manufacturer’s recommendations. Any cracked and damaged finish or sealants, which would allow water ingress, must be repaired immediately by recoating or resealing the effected area. Any damaged flashings or panels must be replaced as for new work.

The durability of the system can also be increased by using Class 4 fixings throughout, additional treatment of steelwork, and by painting all exposed sealants to the sealant manufacturer’s recommendations.

COASTAL AREAS

Hebel PowerPanel^{XL} panels can be used in coastal areas with additional precautions to ensure salt does not build up on the surface of the wall. For buildings up to 1000 metres from a shoreline or large expanse of salt water the following is required:

- All horizontal and vertical movement joints must be appropriately caulked; and
- All walls must be sufficiently exposed from above so that rain can perform natural wash-down of the wall; or
- Walls which are protected by soffits above must be washed down twice per year to remove salt and debris build-up particularly at the joints; and
- In all cases, Class 3 screws must be used.

NOTE: Class 3 screws must be countersunk in outer face of the PowerPanel^{XL} by at least 5mm and filled with Hebel Adhesive.

HEBEL CLADDING WHERE INSTALLED IN FLOOD AFFECTED AREAS

Hebel panels are an autoclaved aerated concrete (AAC) material containing macropores (i.e the air voids in the Hebel material structure) that create a porous structure. The panels are coated with an acrylic coating system generally comprising a base skim coat, texture coat and final coat layer to prevent the ingress of water from inclement weather.

Should Hebel external walls be subject to inundation by flood waters, this will likely affect and possibly breach the integrity of the external coatings and sealants causing the panels to absorb moisture. Although the mineral properties of the Hebel AAC material structure are generally unaffected by moisture, the integrity of the panels must be re-assessed following a flood event, by removal of the external coatings. It is likely that extended periods of inundation could cause long-term damage to the durability of panels (i.e manifested corrosion of reinforcement, damage from impact caused by flood debris etc), in which case, the affected panels should be removed and replaced.

For these reasons, best building practice would be to ensure that the base of panels remain within the freeboard region of the determined and site-specific flood level to avoid inundation, as Hebel AAC panel product warranties following exposure to a flood event are not guaranteed and are subject to the discretion of CSR Hebel.

HEBEL POWERPANEL^{XL}

Hebel PowerPanel^{XL} has many characteristics which make it a very durable product, including:

- Will not rot or burn
- Is not a food source for termites
- Unaffected by sunlight
- Not adversely affected over normal temperature ranges
- One quarter the weight of conventional concrete
- Solid and strong with corrosion protection coated steel reinforcement.

DURABILITY OF COMPONENTS

It is the responsibility of the building designer to ensure that the components such as screws, top hat battens and other steel components have the appropriate corrosion protection to be able to maintain their strength and integrity to suit the required design life of the project.

IMPORTANT: Termite treated timber frames (such as LOSP treated frames) may require sarking to prevent corrosion of steel components. Please refer to frame manufacturer for compatibility. CCA treated pine frames have a deleterious effect on the top hat coatings, which can lead to corrosion. Where timber is CCA treated, provide a barrier between top hat and timber member. Refer to frame manufacture for compliance with the frames compatibility with steel top hats and screw fixings.

When assessing durability the following documents can be referred to for guidance:

- ABCB Guideline Document – Durability in buildings: 2003.
- AS/NZS 2312: 2002 – Guide to the protection of structural steel against atmospheric corrosion by the use of protective coatings.
- ISO 9223: 1992 – Corrosion of metals and alloys – Corrosivity of atmospheres – Classification.
- AS 3566: 2002 – Self drilling screws for the building and construction industries.
- AS 2331 Series.

Reference to AS 3566 should always be adhered to when selecting the screw's corrosion resistance classification.

WALL FRAMES

Steel frames

The designer needs to ensure that the steelwork and Hebel AAC products have adequate protective systems to ensure that durability is maintained. The durability of the stud frame can be enhanced by the provision of a membrane such as sarking. The manufacturer of the steel stud frame can provide guidance on the appropriateness of this solution on a project-by-project basis.

IMPORTANT: The steel frame requirements outlined in the BCA Vol. 2, Part 3.4.2 should be considered in conjunction with steel frame design and construction advice from the steel frame manufacturer. These requirements consist of minimum protective surface coatings with restrictions on the location of the building and exposure condition of the steel frame.

Timber frames

Information on the durability design of timber structures and components can be obtained from documents such as:

- AS 1720.1 Timber Structures, Part 1: Design Methods
- AS 1684 Timber Framing Code
- State timber framing manuals
- AS 3660 Subterranean Termites.



Photo courtesy of Metricon Homes

2.2 FIRE RESISTANCE PERFORMANCE

OVERVIEW

The Hebel PowerPanel^{XL} External Wall System can be subjected to a fire loading as the result of either an external fire source, or an internal fire source. When the wall requires a fire resistance level (FRL) rating, Hebel provides the following guidance:

External fire source

For an external fire source, the excellent fire resistance qualities of the Hebel PowerPanel^{XL} External Wall System protects the structural support framing and provides a high fire resistance level.

NOTE: The FRL rating of the wall can be affected by the penetrations and the method adopted to protect these penetrations. A fire collar with a –/60/60 FRL rating will govern the FRL of the wall, even if the wall configuration has a FRL rating of –/90/90. Where required, the performance of the external coating when subjected to a fire loading shall meet the appropriate performance requirements outlined in the NCC. Joints and gaps need to be appropriately fire rated, e.g. vertical control joint will need fire rated sealant and horizontal joints must be blocked with compressible fire rated material.

Fire certificates and reports

Copies of the test reports and/or opinions can be obtained by contacting Hebel Technical Services. The Hebel PowerPanel^{XL} External Wall System achieves a FRL of up to 180/180/180 minutes up to a maximum wall height limit of 3300mm per level. (CSIRO assessment report FCO-3003)

Only figures 3.6.4.1, 3.6.4.2, 3.6.4.4, 3.6.5.7, 3.6.6.5, 3.6.6.7, 3.6.6.8, 3.6.7.1, 3.6.7.2, 3.6.7.5, 3.6.7.9 and 3.6.7.10 in section 3.6 achieve a fire performance. Where other details are required to provide a fire performance or where a greater Fire Rating Level (FRL) is required, then assessment by a qualified fire engineer is necessary to verify such performance.

Internal fire source

For an internal fire source the studs must be protected by the internal wall linings. The protective lining system can consist of CSR Gyprock FyrchekTM plasterboard fixed to the support framing. The Hebel PowerPanel^{XL} External Wall System can achieve an internal and external (two way) FRL of up to 120/120/120. For more details please contact Hebel Technical services.

External walls in fire – NCC Provisions

Where necessary the designer and builder should ensure the structural support framing, its connections and the Hebel PowerPanel^{XL} installation are satisfactory when subjected to fire conditions. The NCC Vol 2 outlines provisions for external walls for fire resistance in a residential building where the external wall is less than 900mm from an allotment boundary or 1.8m from another building on the same allotment. If this occurs an FRL of not less than 60/60/60 is required from the outside.

FIRE PERFORMANCE OF HEBEL POWERPANEL^{XL}

The Hebel PowerPanel^{XL} External Wall System has been assessed by CSIRO to achieve a Fire Resistance Level (FRL) of up to 180/180/180. Note, the fire source is considered on the PowerPanel^{XL} side. This enables Hebel PowerPanel^{XL} to be used in the following applications:

- Walls on zero line allotment blocks.
- Multi-storey residential dwellings – external walls.

NOTE: In the above applications, each PowerPanel^{XL} panel should be screwed as specified in this guide, except a minimum of three screws should be installed through the middle top hat into each PowerPanel^{XL} panel.

DESIGN CONSIDERATIONS

Fire stop penetrations

Penetrations through Hebel PowerPanel^{XL} to accommodate pipework, electrical cabling or ductwork will have to be protected (fire stop), to prevent the spread of fire through the penetration. The penetration can be protected with proprietary products such as:

- Fire rated sealants.
- Fire collars and intumescent wraps.
- Fire rated mortars.
- Fire rated pillows.
- Fire rated switch boxes.

Hebel recommends contacting the manufacturer to obtain the appropriate product/solution and installation method for the application and wall configuration.

BUSHFIRE ZONE REQUIREMENTS

The Hebel PowerPanel^{XL} External Wall System can achieve the construction requirements up to BAL - FZ as specified in Australian Standard AS 3959. When constructing in BAL - FZ a minimum setback distance of 10m from the edge of the classified vegetation is required. It is the responsibility of the building designer to ensure compliance to AS 3959 is achieved in accordance with clause F2.7.4 of NCC 2019 Volume 2.

2.3 ENERGY EFFICIENCY

NATIONAL CONSTRUCTION CODE (NCC)

The NCC is available in two volumes which align with two groups of 'Class of Building':

- Volume 1 – Class 2 to Class 9 Buildings; and
- Volume 2 – Class 1 & Class 10 Buildings – Housing Provisions.

Each volume presents the Performance Requirements for the efficient use of energy for internal heating and cooling in buildings. The majority of changes have been associated with the Housing Provisions.

The Performance Requirements for energy efficiency ratings are dependent upon the form of construction (i.e. walls or floors), Class of Building, and the type of areas being separated. The performance requirement is a value that is the Total R-Value, which is the cumulative total of the individual R-Values of the building system components.

THE HEBEL POWERPANEL^{XL} EXTERNAL WALL SYSTEM

One of the primary design objectives in planning a building is to provide a cost effective comfortable living / working environment for the building's inhabitants. Exploiting the inherent thermal mass and insulation qualities of Hebel enables the designer to achieve this objective.

Several international comparative studies have been conducted to investigate the benefits of incorporating AAC walls in place of conventional wall systems. A common trend was the lower heating and cooling energy consumption and smaller mechanical equipment required to maintain a comfortable living environment, especially with regards to regions of mainly cold weather. The excellent performance was the result of the three characteristics – thermal mass, thermal insulation and the air tightness of the construction.

The level of insulation provided in a wall is determined by the required Total R-Value. The higher the required Total R-Value the greater the insulation provided. Hebel PowerPanel^{XL} External Wall System incorporating CSR Bradford insulation can provide the R-Value ratings outlined in Tables 2.3.4 and 2.3.5.

THERMAL INSULATION

It is recommended that insulation materials be installed to enhance thermal insulation properties and occupant comfort. Insulation also improves the acoustic performance of the wall against outside noise.

The NCC provides Deemed-to-Satisfy Provisions for compliance and installation of the various types of insulation. The insulation should be installed with Hebel PowerPanel^{XL} such that it forms a continuous barrier to contribute to the thermal barrier. All insulation installed in Hebel PowerPanel^{XL} External Wall systems must comply with: AS/NZS 4859.1; or AS 2464.3 for loose fill insulation.

AIR TIGHTNESS

The thermal performance can be influenced by many factors. Most of these are related to the design decisions and properties of the adopted materials. Construction practices can also significantly affect the performance with poor sealing, resulting in drafts. The tight construction tolerances of AAC provide a wall with low air infiltration rate. Testing at the CSIRO (Test Report DTM327) on Hebel blockwork with thin bed adhesive joints has determined an air infiltration rate of 0.3L/s (0.014% of internal volume). For PowerPanel^{XL} panels having fewer thin bed adhesive joints, a rate less than this could be achieved.

SARKING

As well as controlling condensation and acting as an air barrier, sarking can be used to significantly improve the thermal insulation and energy efficiency performance of a building solution. Sarking layers can alter the performance of the cavity by providing a reflection side. The design of the sarking arrangement is complex and should be performed by the appropriate project consultant.

Where the sarking layer provides a weatherproofing function, the sarking material must comply with AS/NZS 4200 Parts 1 and 2.

The following tables show the performance levels required for walls and floors under the NCC and the thermal performance of the Hebel PowerPanelXL External Wall System.

Figure 2.3.1 Climate zones for thermal design

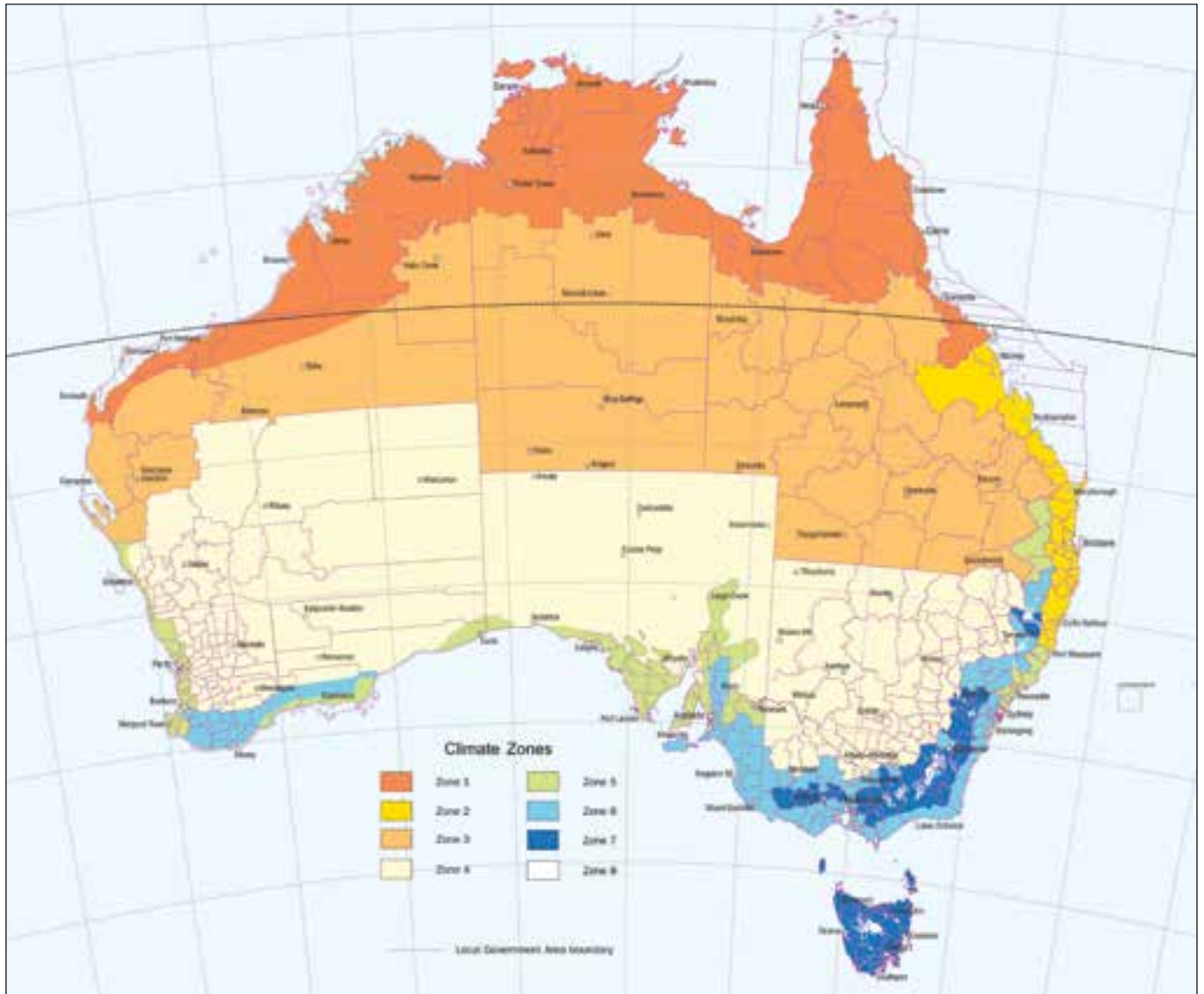

- STEP 1** Determine which climate zone your project is located in Australia from the map.
- STEP 2** From Table 2.3.1, determine the design conditions ('Summer' heat flow in or 'Winter' heat flow out) according to the building class and climate zone for your project. Note: Building classes are defined by the NCC.
- STEP 3** Refer to the roof, wall or floor system applicable to your construction type to determine Total R-Value.

NOTE: Some applications may achieve Total R-Values sufficient to comply with the minimum performance levels of the Deemed-to-Satisfy requirements contained in the Energy Efficiency Provision of the NCC.

Table 2.3.1 Climate zones for thermal design

Climate Zone	1	2	3	4	5	6	7	8
	Below 300metres		Above 300metres					
Class 1-10,2,3,4,9c	Summer		Winter					
Class 5,6,7,8,9a,9b	Summer						Winter	
Class 1-10	Summer		Winter					
Class 2,3,4,5,6,7,8,9a,9b,9c	Summer			Winter				

Table 2.3.2 Low-rise multi-residential buildings

Climate Zone	Options		
1, 2,3,4 and 5	(a)	(i)	Achieve a minimum <i>Total R-Value</i> of 2.8.
	(b)	(i) (ii)	Achieve a minimum <i>Total R-Value</i> of 2.4; and Shade the external wall of the storey with a verandah, balcony, eaves, carport or the like, which projects at a minimum angle of 15 degrees in accordance with Figure 3.12.1.2. of NCC 2019.
6 and 7	Achieve a minimum <i>Total R-Value</i> of 2.8.		
8	Achieve a minimum <i>Total R-Value</i> of 3.8.		

Table 2.3.3 Comparison of thermal properties

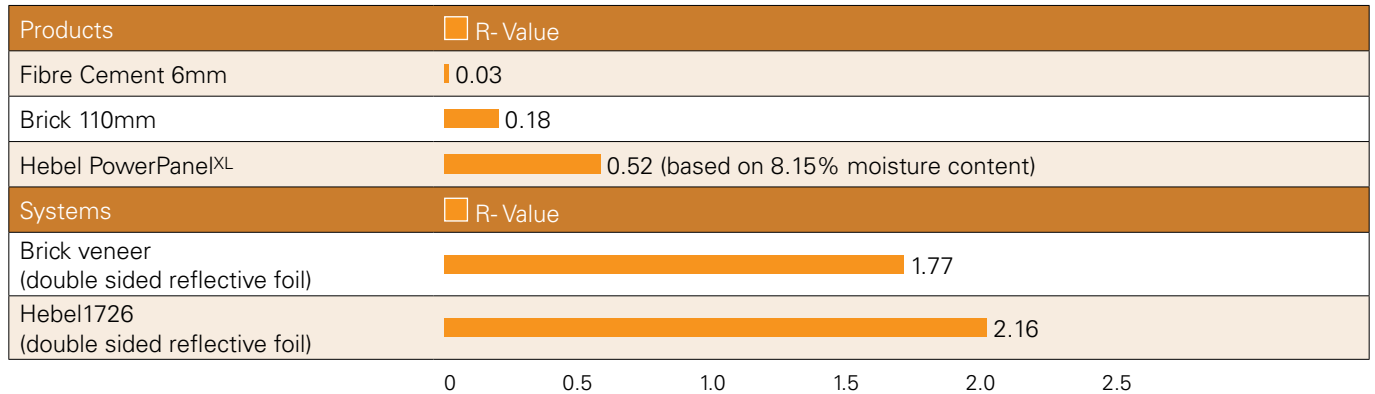

NOTES:

- Sarking or insulation to be added to the above values where applicable to comply with NCC climate zone requirements.
- R-Values above (excluding Hebel PowerPanel^{XL} solution) are taken from NCC 2019.
- Refer to Table 2.3.4 and 2.3.5 for Hebel PowerPanel^{XL} configuration and thermal insulation options.
- R-Values provided for brick veneer have been provided by James Fricker calculation 107.50 dated July, 2010.

Table 2.3.4 Thermal performance of Hebel PowerPanel^{XL} External Wall System - timber stud frame

Hebel code	Description						Total R-value m ² .K/W		
	Platerboard	Stud frame	Batts	Wall wrap	Top hat cavity	Hebel Panel	Summer	Winter	
Hebel1716	10mm Gyprock Plasterboard Plus	70mm timber Stud frame	None	Polyair Performa 4.0 XHD	24mm	75mm thick Hebel PowerPanel ^{XL}	2.13	2.16	
Hebel1752			None	Thermoseal Wall Wrap Prime			1.55	1.59	
Hebel1753			75mm Bradford Gold Wall Batts R1.5	Thermoseal Wall Wrap Prime			2.23	2.36	
Hebel 1717			70mm Bradford Soundscreen Batts R2.0	Thermoseal Wall Wrap XP			2.89	3.01	
Hebel1718			70mm Bradford Soundscreen Batts R2.0	Enviroseal ProctorWrap RW			2.55	2.66	
Hebel1721			None	Polyair Performa 4.0 XHD	35mm		2.13	2.16	
Hebel1754			None	Thermoseal Wall Wrap Prime			1.55	1.59	
Hebel1755			75mm Bradford Gold Wall Batts R1.5	Thermoseal Wall Wrap Prime			2.23	2.36	
Hebel1722			70mm Bradford Soundscreen Batts R2.0	Thermoseal Wall Wrap XP			3.00	3.13	
Hebel1723			70mm Bradford Soundscreen Batts R2.0	Enviroseal ProctorWrap RW			2.65	2.77	
Hebel1726		90mm timber Stud frame	90mm Gyprock Plasterboard Plus	None	Polyair Performa 4.0 XHD		24mm	2.13	2.16
Hebel1760				None	Thermoseal Wall Wrap Prime			1.55	1.59
Hebel1762				90mm Bradford Gold Wall Batts R2.0	Thermoseal Wall Wrap Prime			2.67	2.83
Hebel1727				90mm Bradford Gold Wall Batts R2.0	Thermoseal Wall Wrap XP			2.99	3.15
Hebel1728				90mm Bradford Gold Wall Batts R2.5	Enviroseal ProctorWrap RW			3.00	3.15
Hebel1730				90mm Bradford Gold Wall Batts R2.7	Enviroseal ProctorWrap RW		3.15	3.29	
Hebel1733				None	Polyair Performa 4.0 XHD		35mm	2.13	2.16
Hebel1763				None	Thermoseal Wall Wrap Prime			1.55	1.59
Hebel1764				90mm Bradford Gold Wall Batts R2.0	Thermoseal Wall Wrap Prime			2.67	2.83
Hebel1734				90mm Bradford Gold Wall Batts R2.0	Thermoseal Wall Wrap XP			2.99	3.15
Hebel1735	90mm Bradford Gold Wall Batts R2.5	Enviroseal ProctorWrap RW	3.00	3.15					
Hebel1737	90mm Bradford Gold Wall Batts R2.7	Enviroseal ProctorWrap RW	3.15	3.29					

Table 2.3.5 Thermal performance of Hebel PowerPanelXL External Wall System - steel stud frame

Hebel code	Description						Total R-value m ² .K/W	
	Platerboard	Stud frame	Batts	Wall wrap	Top hat cavity	Hebel Panel	Summer	Winter
Hebel1706	10mm Gyprock Plasterboard Plus	64mm steel Stud frame	None	Polyair Performa 4.0 XHD	24mm	75mm thick Hebel PowerPanelXL	2.13	2.16
Hebel1707			70mm Bradford Soundscreen Batts R2.0	Thermoseal Wall Wrap XP			2.89	3.01
Hebel1708			70mm Bradford Soundscreen Batts R2.0	Enviroseal ProctorWrap RW			2.55	2.66
Hebel1711			None	Polyair Performa 4.0 XHD	35mm		2.13	2.16
Hebel1712			70mm Bradford Soundscreen Batts R2.0	Thermoseal Wall Wrap XP			2.89	3.01
Hebel1713			70mm Bradford Soundscreen Batts R2.0	Enviroseal ProctorWrap RW			2.55	2.66
Hebel1756		70mm steel Stud frame	None	Thermoseal Wall Wrap Prime	24mm		1.44	1.48
Hebel1757			75mm Bradford Gold Wall Batts R1.5	Thermoseal Wall Wrap Prime			2.00	2.11
Hebel1758			None	Thermoseal Wall Wrap Prime	35mm		1.44	1.48
Hebel1759			75mm Bradford Gold Wall Batts R1.5	Thermoseal Wall Wrap Prime			2.00	2.11
Hebel1765		90mm steel Stud frame	None	Thermoseal Wall Wrap Prime	24mm		1.45	1.48
Hebel1766			90mm Bradford Gold Wall Batts R2.0	Thermoseal Wall Wrap Prime			2.35	2.49
Hebel1767			None	Thermoseal Wall Wrap Prime	35mm		1.45	1.48
Hebel1768			90mm Bradford Gold Wall Batts R2.0	Thermoseal Wall Wrap Prime			2.35	2.49
Hebel1740		92mm steel Stud frame	None	Polyair Performa 4.0 XHD	24mm		2.13	2.16
Hebel1741			90mm Bradford Gold Wall Batts R2.0	Thermoseal Wall Wrap XP			2.99	3.15
Hebel1742			90mm Bradford Gold Wall Batts R2.5	Enviroseal ProctorWrap RW			3.00	3.15
Hebel1744			90mm Bradford Gold Wall Batts R2.7	Enviroseal ProctorWrap RW			3.15	3.29
Hebel1747			None	Polyair Performa 4.0 XHD	35mm		2.13	2.16
Hebel1748			90mm Bradford Gold Wall Batts R2.0	Thermoseal Wall Wrap XP			2.99	3.15
Hebel1749			90mm Bradford Gold Wall Batts R2.5	Enviroseal ProctorWrap RW			3.00	3.15
Hebel1751	90mm Bradford Gold Wall Batts R2.7		Enviroseal ProctorWrap RW	3.15		3.29		

Table 2.3.6 Guidance on wall wrap/sarking

Performance criteria	Guidance on wall wrap/sarking	Recommended wall wrap/ sarking	Reflective or non-reflective
Vapour barrier	Vapour barrier products are not recommended for condensation control in colder climate zones in conjunction with high insulation R Values.	Polyair Performa 4.0 XHD	Reflective double-sided
		Thermoseal Wall Wrap Prime	Reflective single-sided
		Thermoseal Wall Wrap XP	Reflective single-sided
Vapour permeable	Vapour permeable products are not recommended for use in tropical climate zones.	Enviroseal ProctorWrap RW	Non-reflective

NOTES:

1. Refer to NCC for state & territory variations.
2. Refer to NCC for alternative means of satisfying the required performance levels.
3. Refer to CSR Bradford product literature for design & installation requirements on wall wrap/ sarking and insulation.
4. The density of Gyprock plasterboard plus is 5.7 kg/m².
5. Stated R-values in Tables 2.3.4 and 2.3.5 has been provided by J.Fricker calculations in report i107e, dated 03/03/2020, and report i107f dated 13/05/2020. Determinations based upon AS/NZS 4859:2018, including thermal bridging.
6. Stated R-values in Tables 2.3.4 and 2.3.5 includes 6mm skim render.
7. As per NCC 2019, where wall wrap is installed in an external wall it must be vapour permeable wall wrap for climate zones 6,7 and 8.
8. For systems where Thermoseal Wall Wrap Prime is used, timber frame size is 70mm x 35mm.

2.4 SOUND TRANSMISSION & INSULATION

OVERVIEW

Current NCC sound transmission and insulation requirements

The Hebel PowerPanel^{XL} External Wall System is primarily used in buildings that have a domestic type of activity purpose. The NCC generally classifies these buildings into Class 1 or 10. The acoustic performance requirements for external walls in these buildings or their building elements are not currently stated in the NCC. If a building using the Hebel wall system was required to provide acoustic performance, then the performance level requirements for a building envelope and elements would be set by the relevant authorities (i.e. local councils, client specific requirements, etc).

Design recommendations

Acoustic design is a complex science and there will be instances where a specialist acoustic consultant is required.

For walls requiring acoustic performance Hebel recommends:

1. Engaging a reputable acoustic consultant on a project-by-project basis to provide design advice and installation inspections
2. When selecting the appropriate components for the Hebel wall system, the designer or specifier must be aware that the laboratory R_w values are almost always higher than the field measured values. Therefore, allowances should be made for the lower expected field values during the selection of the system
3. Separate advice from a specialist acoustic consultant should be sought to determine the effect on acoustic performance due to any changes to the Hebel wall system, and any required modification of the installation details pertaining to the systems
4. Increasing cavity widths, using higher density or thicker insulation or plasterboard, will generally maintain or increase the acoustic performance of the Hebel wall system.

Table 2.4.1 Acoustic performance of Hebel PowerPanel^{XL} External Wall System - timber stud frame

Hebel code	Description						Acoustic	
	Platerboard	Stud frame	Batts	Wall wrap	Top hat cavity	Hebel Panel	R_w	$R_w + C_{tr}$
Hebel1716	10mm Gyprock Plasterboard Plus	70mm timber Stud frame	None	Polyair Performa 4.0 XHD	24mm	75mm thick Hebel PowerPanel ^{XL}	38	23
Hebel1717			70mm Bradford Soundscreen Batts R2.0	Thermoseal Wall Wrap XP			40	25
Hebel1718			70mm Bradford Soundscreen Batts R2.0	Enviroseal ProctorWrap RW			40	25
Hebel1721			None	Polyair Performa 4.0 XHD	35mm		38	23
Hebel1722			70mm Bradford Soundscreen Batts R2.0	Thermoseal Wall Wrap XP			41	26
Hebel1723			70mm Bradford Soundscreen Batts R2.0	Enviroseal ProctorWrap RW			41	26
Hebel1726		90mm timber Stud frame	None	Polyair Performa 4.0 XHD	24mm	38	23	
Hebel1727			90mm Bradford Gold Wall Batts R2.0	Thermoseal Wall Wrap XP		41	26	
Hebel1728			90mm Bradford Gold Wall Batts R2.5	Enviroseal ProctorWrap RW		41	26	
Hebel1730			90mm Bradford Gold Wall Batts R2.7	Enviroseal ProctorWrap RW	41	26		
Hebel1733			None	Polyair Performa 4.0 XHD	35mm	38	23	
Hebel1734			90mm Bradford Gold Wall Batts R2.0	Thermoseal Wall Wrap XP		42	27	
Hebel1735			90mm Bradford Gold Wall Batts R2.5	Enviroseal ProctorWrap RW		42	27	
Hebel1737			90mm Bradford Gold Wall Batts R2.7	Enviroseal ProctorWrap RW		42	27	

Table 2.4.2 Acoustic performance of Hebel PowerPanel^{XL} External Wall System - steel stud frame

Hebel code	Description						Acoustic	
	Platerboard	Stud frame	Batts	Wall wrap	Top hat cavity	Hebel Panel	R_w	$R_w + C_{tr}$
Hebel1706	10mm Gyprock Plasterboard Plus	64mm steel Stud frame	None	Polyair Performa 4.0 XHD	24mm	75mm thick Hebel PowerPanel ^{XL}	40	30
Hebel1707			70mm Bradford Soundscreen Batts R2.0	Thermoseal Wall Wrap XP			43	32
Hebel1708			70mm Bradford Soundscreen Batts R2.0	Enviroseal ProctorWrap RW			43	32
Hebel1711			None	Polyair Performa 4.0 XHD	35mm		40	31
Hebel1712			70mm Bradford Soundscreen Batts R2.0	Thermoseal Wall Wrap XP			44	33
Hebel1713			70mm Bradford Soundscreen Batts R2.0	Enviroseal ProctorWrap RW			44	33
Hebel1740		92mm steel Stud frame	None	Polyair Performa 4.0 XHD	24mm	40	31	
Hebel1741			90mm Bradford Gold Wall Batts R2.0	Thermoseal Wall Wrap XP		44	33	
Hebel1742			90mm Bradford Gold Wall Batts R2.5	Enviroseal ProctorWrap RW		44	33	
Hebel1744			90mm Bradford Gold Wall Batts R2.7	Enviroseal ProctorWrap RW	44	33		
Hebel1747			None	Polyair Performa 4.0 XHD	35mm	40	31	
Hebel1748			90mm Bradford Gold Wall Batts R2.0	Thermoseal Wall Wrap XP		44	33	
Hebel1749			90mm Bradford Gold Wall Batts R2.5	Enviroseal ProctorWrap RW		44	33	
Hebel1751			90mm Bradford Gold Wall Batts R2.7	Enviroseal ProctorWrap RW		44	33	

NOTE: Acoustic values in Tables 2.4.1 and 2.4.2 are based on acoustic assessment 20140366.34/1909A/R3/GW.

2.5 COATING REQUIREMENTS

Hebel PowerPanel^{XL} panels require an appropriate external coating system and sealant detailing to ensure a water resistant and vapour permeable building envelope is achieved.

Generally, the external face of the Hebel PowerPanel^{XL} panel is coated with a high build acrylic levelling and finishing system, applied in accordance with the recommendations of the coating manufacturer.

NOTE: The coating system is a necessary part of the Hebel PowerPanel^{XL} external wall system to ensure the durability of the panel, validity of the applicable warranty and weathertightness of wall system is maintained. Hebel recommends the coating system to be applied as soon as possible, but within 60 days from the date of installation of Hebel PowerPanel^{XL} panels.

Prior to application of the coating it must be ensured that:

- The PowerPanel^{XL} panels are dry
- The panel substrate is clean from any dirt, imperfections or contamination that may prevent adhesion of the coating system onto the panel

PERFORMANCE REQUIREMENTS

The following are items to be considered when selecting a coating system:

Manufacturer approved:

- Hebel recommends the use of a three layer coating system. The application of a two layer coating system is also acceptable. The acrylic coating manufacturer must ensure they have evidence of suitability of their coating system over the Hebel substrate, where a two layer coating system is used.

NOTE: Where other manufacturer's coating systems are applied to Hebel external walls these coatings systems must be warranted by the coating manufacturer as appropriate for coating an AAC substrate. As a minimum coating manufacturers must verify and warrant coating system performance to the properties defined below. Coating application rates and film thickness must comply with (or exceed) the coating system manufacturer's minimum specifications.

Surface adhesion:

- The substrate preparation and coating application should be in accordance with the coating manufacturer's specification.
- Before applying finishes in coastal areas (Refer to Section 2.1 – Durability), all PowerPanel^{XL} panels must be thoroughly washed with fresh water to remove any salt residue. Refer to coating manufacturer for additional requirements.

Water resistance:

- The primary objective of the coating system is to prevent liquid water ingress, yet allow water vapour transmission both in and out of the AAC substrate.
- Proven water resistance capability: Transmission: <10 grams/m²/24hr/1kPa.

Water vapor permeability:

- For a coating to allow the 'escape' of water vapour, the coating must be vapour permeable.
- The coating system should comply with the following performance parameters:
 - Equivalent air layer thickness of water vapor diffusion $S_d \leq 2m$.

NOTE:

- A coating with an ($s_d \leq 2m$) has less resistance to water vapour diffusion (escape) than a static 2m thick air layer.

Compatibility:

- Ensure the coating system is compatible with the AAC substrate and construction system components, i.e:
 - Coatings may not adhere to silicone or other sealants and mastics.
 - Excessive joint adhesive or mortars smears across the panel face may require removal or specific primers.

Durability:

- The coating must be durable and should not overly deteriorate with exposure to light (UV) and weather for the life of the coating system manufacturer's warranty.

Coating Elasticity:

- The coating system must be able to bridge a 1mm minimum crack width.
- The coating system manufacturer can specify the minimum design specification (thickness), so that the coating is serviceable and durable.

IMPORTANT: This list of performance requirements indicates that a specific fit-for purpose coating system must be adopted, and that a simple paint coating would most likely be an inadequate coating system. Variations to the coating system must be approved and warranted by the coating system manufacturer or representative. Coating application rates and film thickness must comply with (or exceed) the coating system manufacturer's minimum specifications.

Maintenance:

All external coating systems and sealants/caulking should be cleaned and maintained on a regular basis. Please refer to Section 2.1 - Durability.

Contact reputable coating manufacturers for their current coating maintenance guide.

2.6 WEATHERPROOFING

SEALANTS

All control joints must be sealed with a suitable external grade acoustic and/or fire rated paintable sealant. All gaps between the PowerPanel^{XL} panels and framing around windows must be caulked with an appropriate external grade sealant.

NOTE: Caulking should be applied prior to base coat with care taken not to cut the caulking during application of trowelled on render/coating.

The sealant should be installed in accordance with the sealant manufacturer's specifications.

WALL FLASHINGS

In general, flashings shall be designed and installed in accordance with SAA-HB39 2015 – Installation Code for Metal Roofing and Wall Cladding.

NCC 2019 Volumes One and Two contain Performance Requirement (P2.4.7) relating to Condensation and Water Vapour Management and requirement states:

CONDENSATION MANAGEMENT

Risks associated with water vapour and condensation must be managed to minimise their impact on the health of occupants.

This requirement implies that moisture levels resulting from condensation within the building must be managed such that they do not cause undue (health) impacts to occupants living within the building.

Hebel has undertaken Hygrothermal modelling in accordance with Verification Method, V2.4.7 - Verification of condensation management of NCC 2019 of the Hebel PowerPanel^{XL} Dual Zero Boundary and External Wall Systems to justify that moisture levels satisfy the intent of Performance Requirement P2.4.7 and that omitting the installation of wall wrap in the Hebel PowerPanel^{XL} Dual Zero Boundary and External Wall Systems will not cause a risk of condensation. (Report Ref: ff0054(03) Hygrothermal_Assessment prepared by Fabric First dated 19th April 2020).

However, where a wall wrap is installed, particularly in climatic zones 6,7 & 8, this wall wrap must be a vapour permeable membrane.

WALL WRAP

For Hebel PowerPanel^{XL}, wall wrap is recommended for insulation, condensation control as well as a corrosion barrier over CCA treated timber frames.

Where wall wrap is installed in an external wall it must be of a vapour permeable type for climate zones 6, 7 and 8 as per NCC 2019 Volume Two Clause 3.8.7.2 Pliable building membrane. Wall wrap must be designed and installed in accordance with AS/NZS 4200 Part 1 – Materials and Part 2 – Installation.

ZERO BOUNDARY WALL SYSTEM

Hebel zero boundary walls are used when access is unavailable from outside. The design and installation of the zero boundary walls should be based on the information and details provided in this guide.

On zero boundary wall applications where the external wall is up against another existing building, it is good practice to flash the top of the wall to the adjacent property to shelter the wall from external weather conditions. In cases where Hebel zero boundary wall is higher than the wall on the adjacent property, the Hebel wall cladding at the upper level is considered an external wall system and therefore should be coated as per the recommendations in this guide. For more details refer to figures 3.6.6.7 and 3.6.6.8 and Hebel technical update (Doc Ref: Boundary wall weathertightness. doc - 14 Nov 2011).

POWERPANEL^{XL} EXTERNAL WALL SYSTEM

The Hebel PowerPanel^{XL} External Wall System has been tested (and results of the test assessed by AECOM) in accordance with the Verification Methods of NCC 2019, specifically the verification methods FV1 for clause FP1.4 (Volume One) and V2.2.1 for clause P2.2.2 (Volume Two).

The results of this test demonstrate the Hebel PowerPanel^{XL} External Wall System (with adhesive applied at the panel joints) and with a suitable acrylic coating system applied over the panel will comply with the performance requirements NCC 2019 for Wind Categories N2 & N3, specifically the verification methods FV1 for clauses FP1.4 (Volume One) and V2.2.1 for clause P2.2.2 (Volume Two).

FACE-SEALED SYSTEM

The Hebel PowerPanel^{XL} External Wall System is considered a face-sealed system (functioning as a closed, un-drained cavity wall system, excluding weepholes) whereby the external coatings and sealant at control joints, around external window and door openings etc. form the weather tightness barrier to the external wall of the building. As such, a fit-for-purpose acrylic coating system and compatible external grade sealants, applied in accordance with manufacturers specification (and maintained in accordance with the manufacturers maintenance schedule) are important in ensuring the ongoing weather tightness performance and long term durability of the external wall system.

3.1 INSTALLATION OVERVIEW

1. COMPLETE FRAMES AND TRUSSES

2. DPC

- Fix DPC to bottom plate of frame
- Cover rebate completely
- Overlap DPC at corners



3. WALL WRAP

- Install wrap as specified by supplier ensuring that it overlaps DPC at base



4. TOP HATS

- Check control joint layouts for installation of discontinuous top hats
- Check the number of top hats and screws required (refer to tables on pages 6 and 7)
- Use packers and pack top hat to string line where required, screw to frame
- Check with a straight edge/spirit level that top hats are plumb
- Install top hats above and below openings



5. CUTTING PANELS

- Cut panels to size (refer to Appendix A notes on page 54)
- Ensure any exposed steel reinforcing has been coated with Hebel anti-corrosion paint



6. ADHESIVE

- Mix adhesive to a thick flowable consistency
- Apply Hebel adhesive to entire edge of panel with notched trowel
- The use of notched trowel to apply Hebel adhesive at the panel joints is essential to ensure sufficient adhesive is applied. Insufficient application of adhesive at the panel joints may result in hairline cracks at the joints.



7. CONTROL JOINT

- Check control joint layout
- Install backing rod into control joint at the required depth
- Apply suitable sealant to control joint
- Clean up any excess sealant ensuring it does not adhere to panel face



8. HEBEL POWERPANEL^{XL} PANELS

- Corner PowerPanel^{XL} panel to be installed first, lifting into place using panel lifters
- Fix panel to top hats (refer to tables on pages 6 and 7)
- Check panel is straight and level
- Continue installation by lifting panels into position
- Butt panel tightly to adjoining panel, screwing off as you go
- Adhesive should slightly ooze from the joint
- Once the joint adhesive is semi hard it can be cleaned up with a pallet knife, ensuring adhesive is flush with the panel face
- Patch holes and panel damage



9 FINISH WALL

- Trim off excess DPC
- Lightly sand and prepare surface ready for acrylic coating



3.2 TOOLS AND EQUIPMENT

The basic tools required to assist in the installation of the PowerPanel^{XL} External Wall System are shown in Figure 3.2.1. These may be purchased through a Hebel distributor and include:

- 1. Stirrer** – fitted to the electric drill, the stirrer is used to mix the Hebel Mortar, Hebel Adhesive and base levelling coat render inside the mixing bucket
- 2. Notched trowel** – the notched trowel is used to apply the Hebel Adhesive to the Hebel surfaces. The width of the trowel must match the panel thickness to ensure the adhesive is applied with full and even coverage
- 3. Panel lifters** – used to carry the panels around the work site
- 4. Sand float** – used to remove excess Hebel Adhesive and smooth joints between panels
- 5. Levelling plane** – used to even out inconsistencies in the Hebel panels.

Extra equipment will also be required and includes the following:

- Power drill (clutch driven)
- Power saw with metal or diamond tipped cutting blades
- Dust extraction system
- Sockets for screws
- Personal Protective Equipment (PPE) such as goggles, ear muffs/plugs and face mask used when site cutting the PowerPanel^{XL} panels.

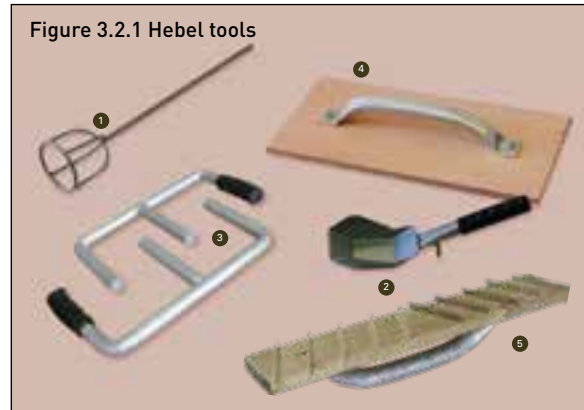

3.3 INSTALLATION OF SERVICES

The installation of services in the building are the same as the methods currently being used throughout the industry.

Services should be installed through the frame to avoid interfering with top hat layout, but if they are to be fixed on the outside of the frame, they should only run horizontally



Figure 3.3.1 Installed piping services prior to the installation of Hebel PowerPanel^{XL}

parallel to the top hats – typically 300mm up from the bottom plate.

Penetrations through the PowerPanel^{XL} panel for services should be neatly filled and the joint sealed.



Figure 3.3.2 Neat finishes of installed services

3.4 EXTERNAL ALUMINIUM RENDER BEAD (OPTIONAL)



Figure 3.4.1 Neat finish of horizontal joints

The external aluminium render bead can be used as an option at horizontal joints to provide neat and consistent finish joints. After installation of the PowerPanel^{XL} panels, the render bead is applied and hold onto place by using Hebel adhesive. Suitable external grade sealant is to be applied at the joint before rendering.

NOTES:

The external aluminium render bead is not recommended in the following conditions:

- Within 100m of breaking surf.
- Within 100m of heavy industrial emissions.
- Areas exposed to prevailing winds containing salt of heavy industrial emissions.
- Where continuous or cyclical moisture is present (eg retaining walls, planter boxes, garden beds)
- Environments where bore water or soils contain high chloride content.

3.5 CONSTRUCTION DETAILS – OVERVIEW

Table 3.5.1 CONSTRUCTION DETAILS

Single storey construction details	Isometric view detail panel supported at base	Figure 3.6.1.1	Page 28
	Isometric view detail panel suspended	Figure 3.6.1.2	Page 28
	Hip roof elevation	Figure 3.6.1.3	Page 29
	Gable end elevation	Figure 3.6.1.4	Page 29
	Typical section detail	Figure 3.6.1.5	Page 30
	High wall section detail (3900mm max.)	Figure 3.6.1.6	Page 30
Two storey construction details	Isometric view detail	Figure 3.6.2.1	Page 31
	Hip roof elevation	Figure 3.6.2.2	Page 32
	Gable end elevation	Figure 3.6.2.3	Page 32
	Typical timber frame section using joists with >1% shrinkage	Figure 3.6.2.4	Page 33
	Steel frame section or engineered joists with ≤1% shrinkage	Figure 3.6.2.5	Page 33
	Hebel external wall cladding detail extending above first floor	Figure 3.6.2.6	Page 34
Two storey addition details	Isometric view detail	Figure 3.6.3.1	Page 34
	Typical section with brick veneer below	Figure 3.6.3.2	Page 35
	Typical section with double brick below	Figure 3.6.3.3	Page 35
Fixing & installation details	Hebel PowerPanel ^{XL} External Wall System fixing detail	Figure 3.6.4.1	Page 36
	Hebel PowerPanel ^{XL} zero Boundary Wall System fixing detail	Figure 3.6.4.2	Page 36
	Screw layout drawing	Figure 3.6.4.3	Page 36
	PowerPanel ^{XL} zero Boundary Wall System	Figure 3.6.4.4	Page 36
Footing junction details	Junction to shallow concrete footing	Figure 3.6.5.1	Page 37
	Junction to deep concrete edge beam	Figure 3.6.5.2	Page 37
	Junction to masonry earth retaining wall	Figure 3.6.5.3	Page 37
	Junction to masonry dwarf wall	Figure 3.6.5.4	Page 37
	Junction to existing piers/stumps	Figure 3.6.5.5	Page 38
	Base detail suspended floor - pier connection	Figure 3.6.5.6	Page 38
	Junction to shallow concrete edge beam	Figure 3.6.5.7	Page 39
	Junction to steel angle	Figure 3.6.5.8	Page 39
	Junction to Hebel below finish ground	Figure 3.6.5.9	Page 39
	Junction to Hebel below concrete pavement slab	Figure 3.6.5.10	Page 39
Wall junction details & sections	Typical roof eaves detail – Option 1	Figure 3.6.6.1	Page 40
	Typical roof eaves detail – Option 2	Figure 3.6.6.2	Page 40
	Roof to wall junction detail - Option 1	Figure 3.6.6.3	Page 40
	Roof to wall junction detail - Option 2	Figure 3.6.6.4	Page 40
	Typical roof eaves detail for zero boundary wall systems	Figure 3.6.6.5	Page 40
	Balcony detail	Figure 3.6.6.6	Page 40
	Zero boundary wall detail to Hebel PowerPanel ^{XL} external wall system	Figure 3.6.6.7	Page 41
	Zero boundary wall detail to brick veneer	Figure 3.6.6.8	Page 41

Wall junction details & sections	Parapet capping	Figure 3.6.6.9	Page 41
	Hebel to pitched roof junction	Figure 3.6.6.10	Page 41
	Gable end wall detail	Figure 3.6.6.11	Page 42
	Gable end wall detail – lintel panel over window	Figure 3.6.6.12	Page 42
	Beam penetration detail	Figure 3.6.6.13	Page 42
	Column detail (glued and screwed)	Figure 3.6.6.14	Page 42
Control joint details	Internal corner	Figure 3.6.7.1	Page 43
	External corner	Figure 3.6.7.2	Page 43
	Typical detail for control joints positioned on corner	Figure 3.6.7.3	Page 44
	Typical detail for control joints positioned away from a corner	Figure 3.6.7.4	Page 44
	Typical horizontal control joint – engineered timber or steel frame	Figure 3.6.7.5	Page 45
	Horizontal control joint – cavity brickwork to Hebel PowerPanel ^{XL}	Figure 3.6.7.6	Page 45
	Horizontal control joint – Brick veneer to Hebel PowerPanel ^{XL} - Option 1	Figure 3.6.7.7	Page 45
	Horizontal control joint – Brick veneer to Hebel PowerPanel ^{XL} - Option 2	Figure 3.6.7.8	Page 45
	Typical vertical control joint	Figure 3.6.7.9	Page 45
	Typical vertical control joint with double studs	Figure 3.6.7.10	Page 45
	Control joint – aligned top hats on double stud	Figure 3.6.7.11	Page 46
	Control joint – discontinuous top hats on a single stud	Figure 3.6.7.12	Page 46
	Typical window control joint detail – lintel over	Figure 3.6.7.13	Page 46
Door & window details	Typical window sill detail – aluminium window frame – Option 1	Figure 3.6.8.1	Page 47
	Typical window sill detail – aluminium window frame – Option 2	Figure 3.6.8.2	Page 47
	Typical window sill detail – aluminium window frame – Option 3	Figure 3.6.8.3	Page 47
	Header detail	Figure 3.6.8.4	Page 47
	Garage head detail	Figure 3.6.8.5	Page 47
	Garage door – jamb detail – Option 1	Figure 3.6.8.6	Page 47
	Garage door – jamb detail – Option 2	Figure 3.6.8.7	Page 47
	Sliding door sill detail – Concrete sill < 270mm	Figure 3.6.8.8	Page 48
	Sliding door sill detail – PowerPanel ^{XL} sill > 270mm	Figure 3.6.8.9	Page 48
Miscellaneous detail	Panel layout drawing – Plan view	Figure 3.6.9.1	Page 49

Project specific requirements: please contact CSR Hebel for advice on any project specific designs not covered in this Design and Installation Guide.

3.6 CONSTRUCTION DETAILS

3.6.1 SINGLE STOREY CONSTRUCTION DETAILS

Figure 3.6.1.1 Single storey construction – isometric view detail panel supported at base

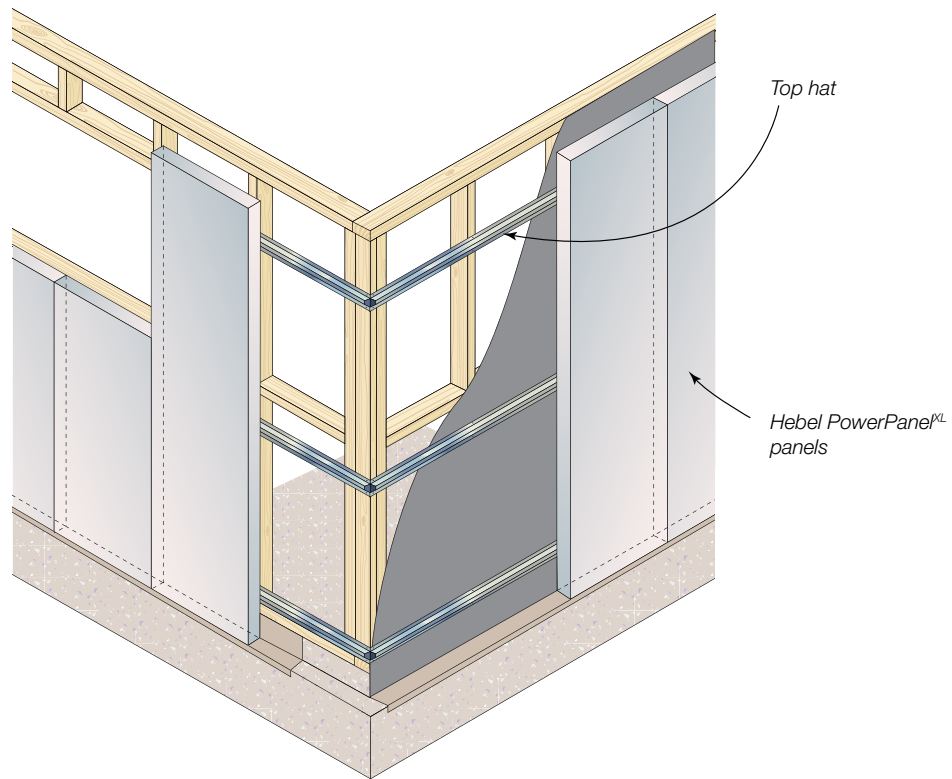
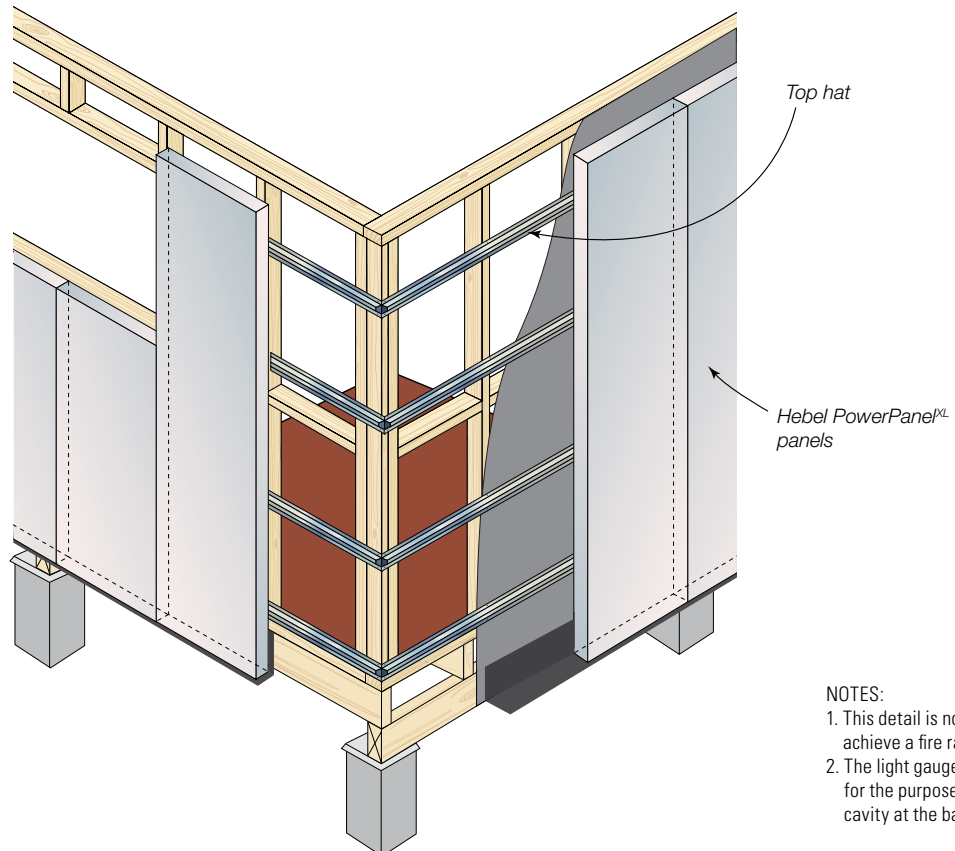

Figure 3.6.1.2 Single storey construction – isometric view detail panel suspended



- NOTES:
1. This detail is not considered to achieve a fire rating level.
 2. The light gauge steel angle is for the purpose of closing the cavity at the base of the wall.

Figure 3.6.1.3 Single storey construction – hip roof elevation

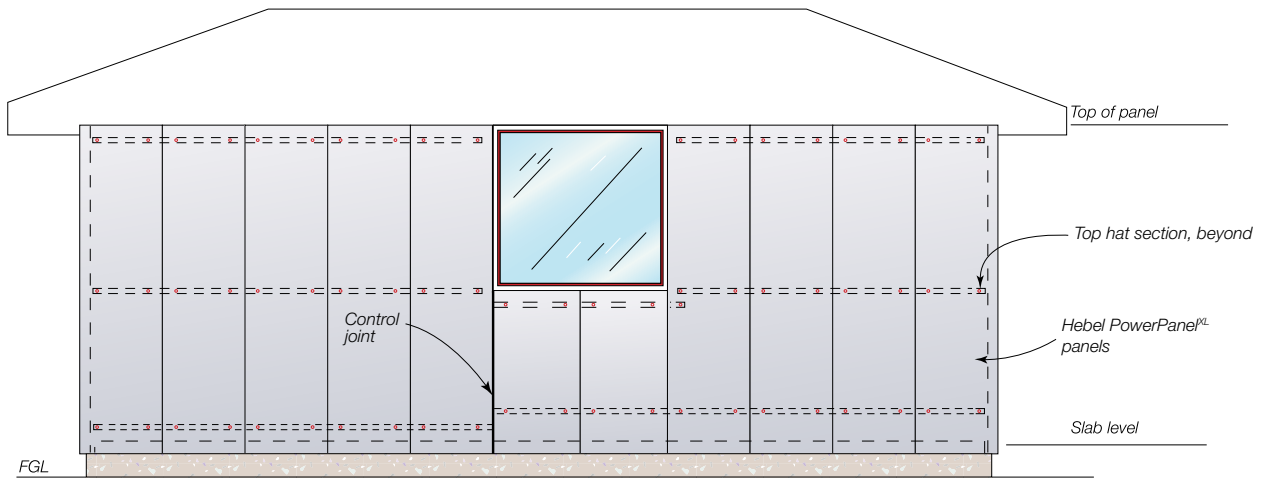
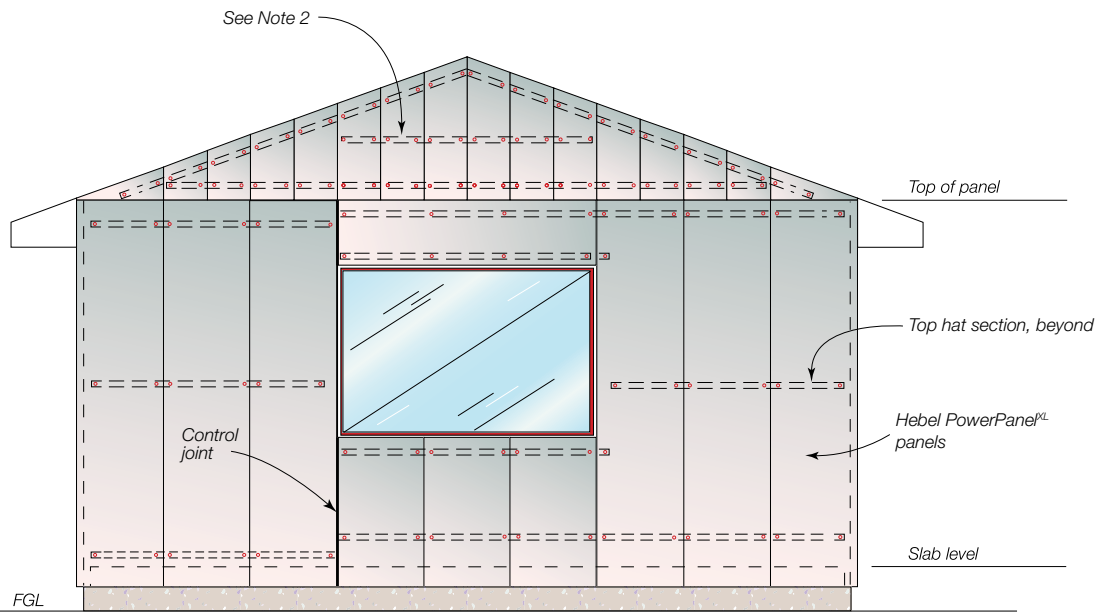

Figure 3.6.1.4 Single storey construction – gable end elevation



NOTES:

1. Number of top hats and top hat spacing to be confirmed by the building designer.
2. Additional top hats may be required, for suspended panels. Refer to Table 1.2.4 of this guide.
3. These details have not shown the set-out of top hats to accommodate control joint locations. This is the responsibility of the building designer.
4. Horizontally installed Hebel PowerPanelXL panels above openings can be installed with top hat sections running horizontally or vertically. A minimum 3 top hat sections will be required for vertically installed top hats. All top hats to be spaced evenly, with the two outer top hats installed 250mm (maximum) from the end of the PowerPanelXL. Refer to design tables 1.2.1 and 1.2.2.

Figure 3.6.1.5 Single storey construction – typical section detail

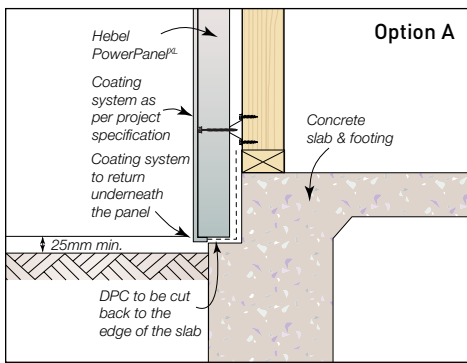
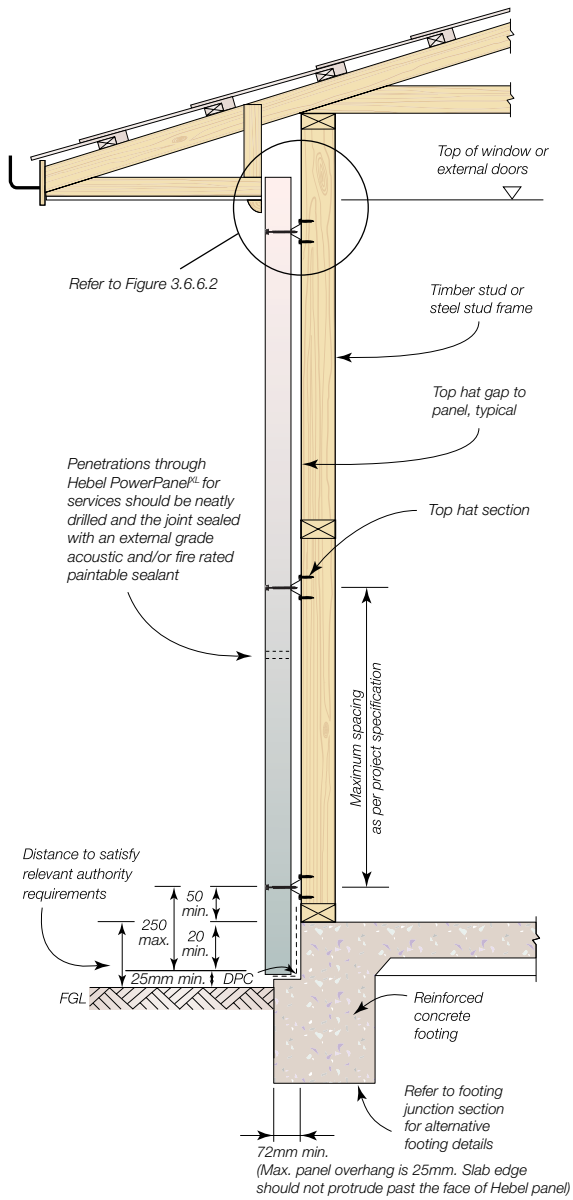
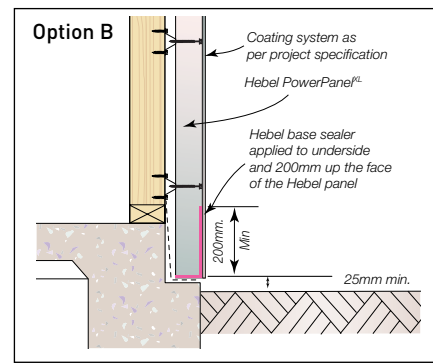
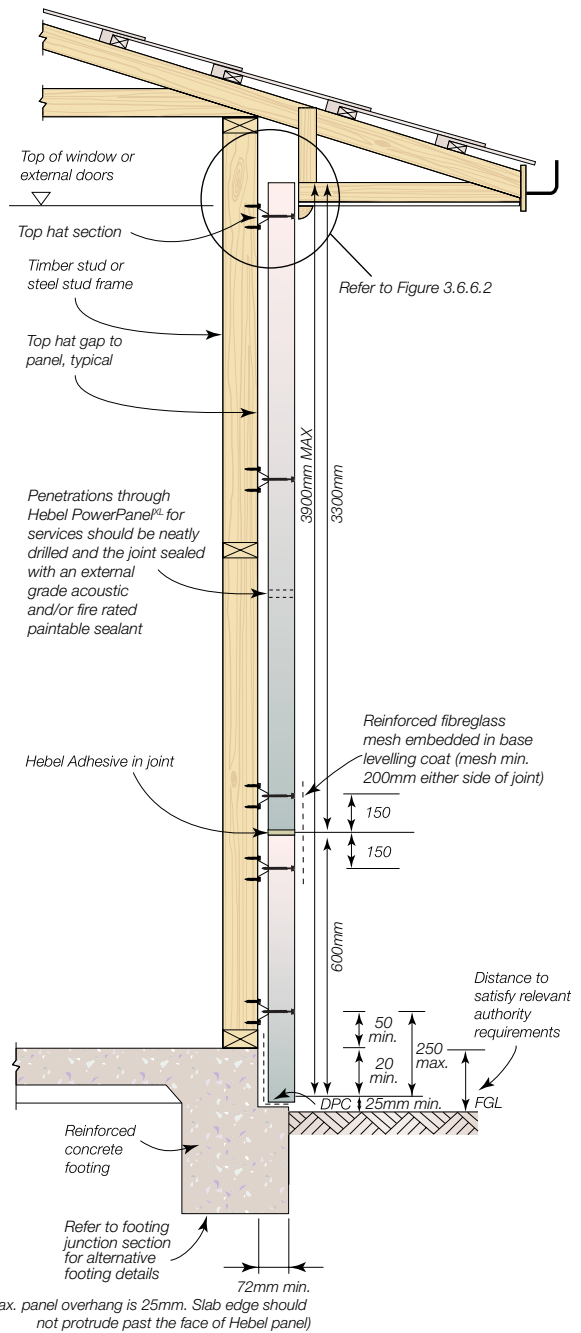

Figure 3.6.1.6 Single storey construction – high wall section detail (3900mm max.)



NOTES:

1. Figures 3.6.1.5 and 3.6.1.6 slab edge details do not comply with the termite visible inspection zone requirements. Alternate termite management systems must be used when selecting these details. It is the responsibility of the builder to provide a suitable physical or chemical barrier in accordance with AS 3660.
2. Hebel PowePanelXL panels are supported at the base on concrete slab edge.
3. The distance from the underside of the PowerPanelXL panel to Finished Ground Level (FGL) may be 25mm min. or as per relevant authority requirements, see option A and B. Ensure soil is cut away at the slab edge to provide enough room to accommodate the coating of the underside of the panel (applies to option A only). For more details please contact Hebel Technical services to obtain a copy of Hebel Technical Update TU-033.
4. Where the slab edge is rendered on sites that contain saline soils, please refer to page 10 of the guide for further details.

3.6.2 TWO STOREY CONSTRUCTION DETAILS

Figure 3.6.2.1 Two storey construction – isometric view detail

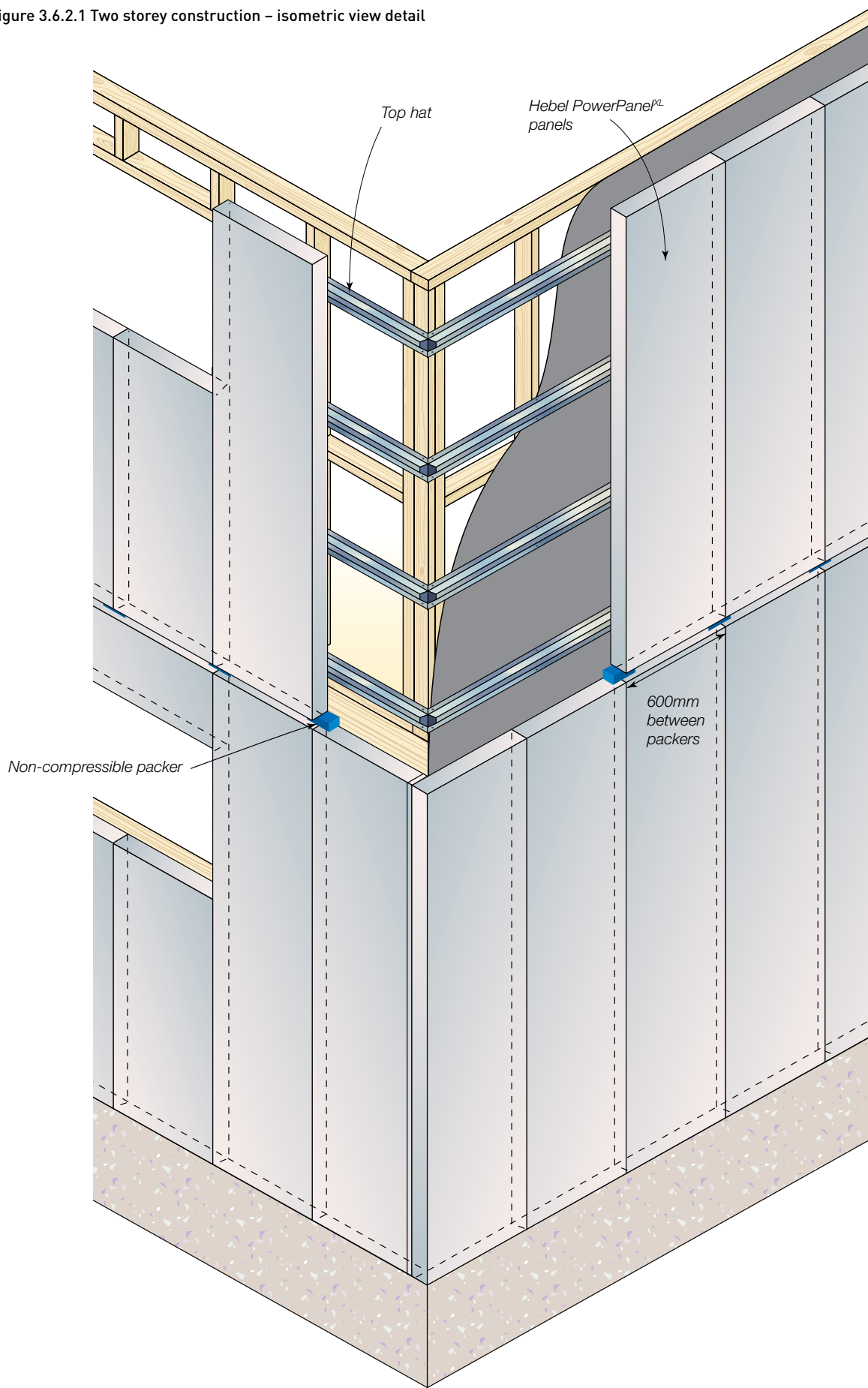

Figure 3.6.2.2 Two storey construction – hip roof elevation

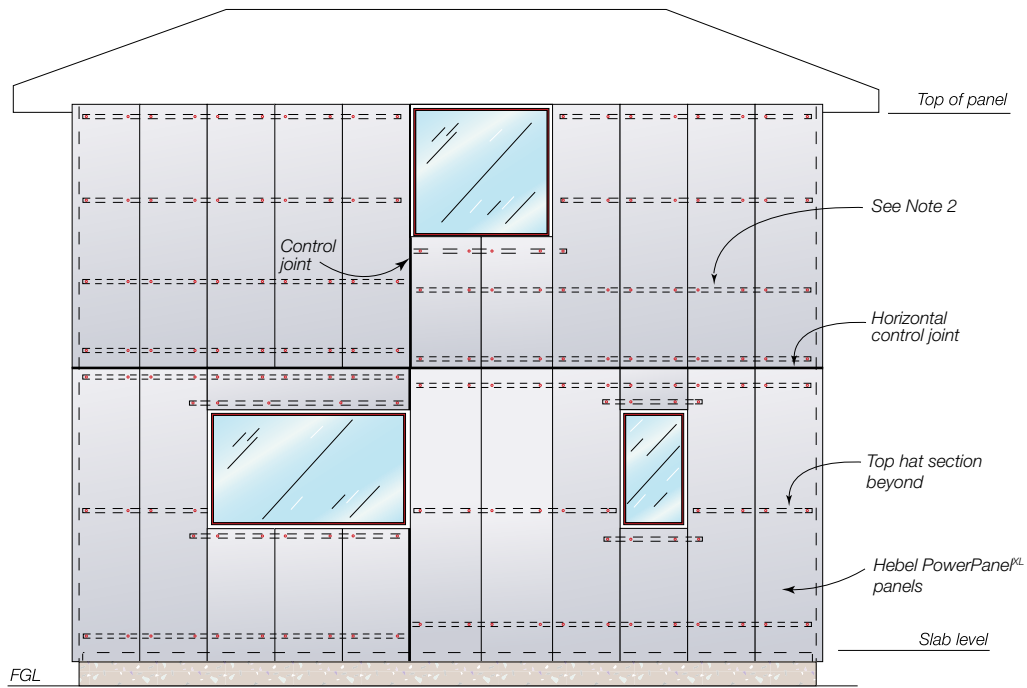
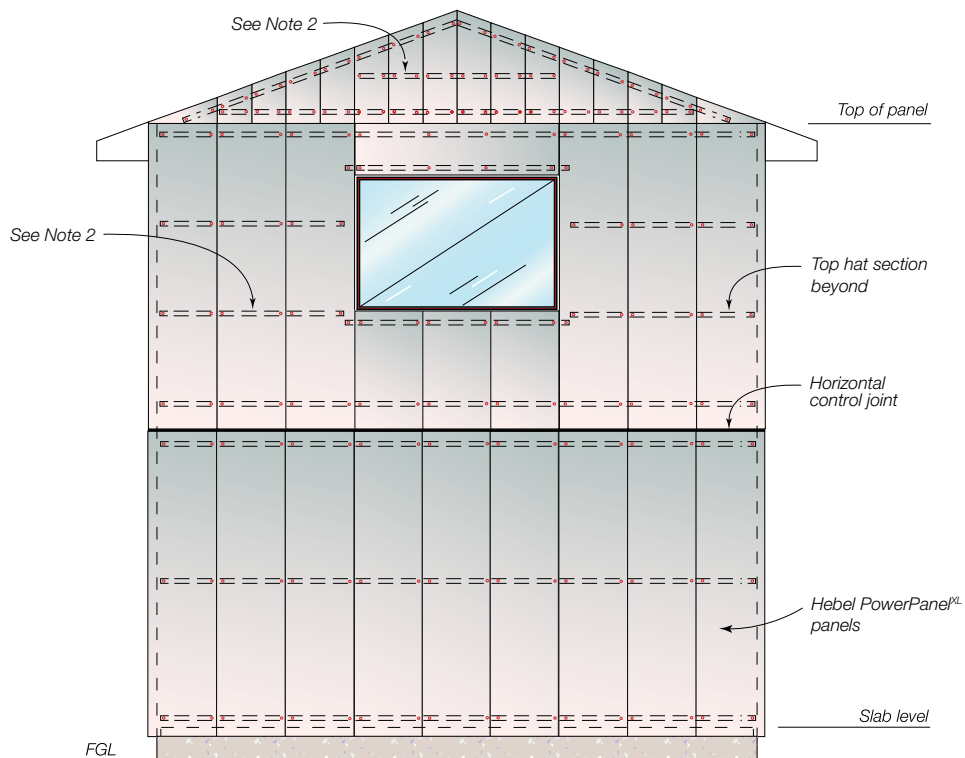

Figure 3.6.2.3 Two storey construction – gable end elevation



NOTES:

1. Number of top hats and top hat spacing to be confirmed by the building designer.
2. Additional top hats may be required, for suspended panels. Refer to Table 1.2.4 of this guide.
3. These details have not shown set-out of top hats to accommodate control joint locations. This is the responsibility of the building designer.
4. Frame design of lower floor to allow for extra load on wall from upper floor PowerPanelXL panels.
5. Minimum four horizontal top hats required for upper floor PowerPanelXL panels.
6. Horizontally installed Hebel PowerPanelXL panels above openings can be installed with top hat sections running horizontally or vertically. A minimum 3 top hat sections will be required for vertically installed top hats. All top hats to be spaced evenly, with the two outer top hats installed 250mm (maximum) from the end of the PowerPanelXL. Refer to design tables 1.2.1 and 1.2.2.

Figure 3.6.2.4 Two storey construction – typical timber frame section using joists with >1% shrinkage

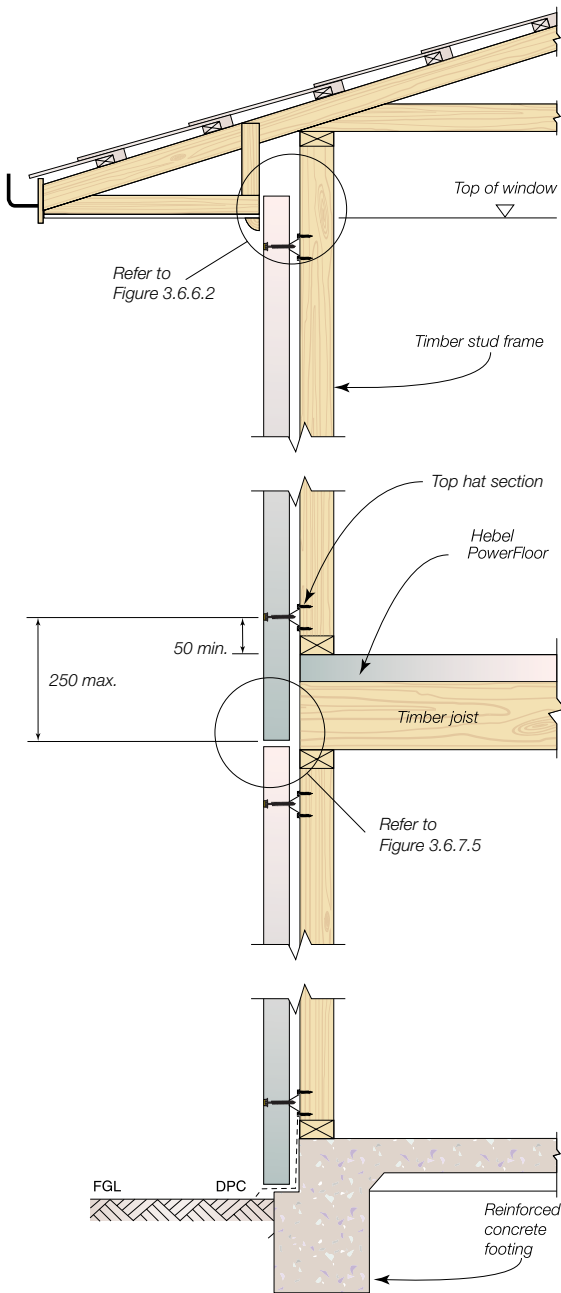
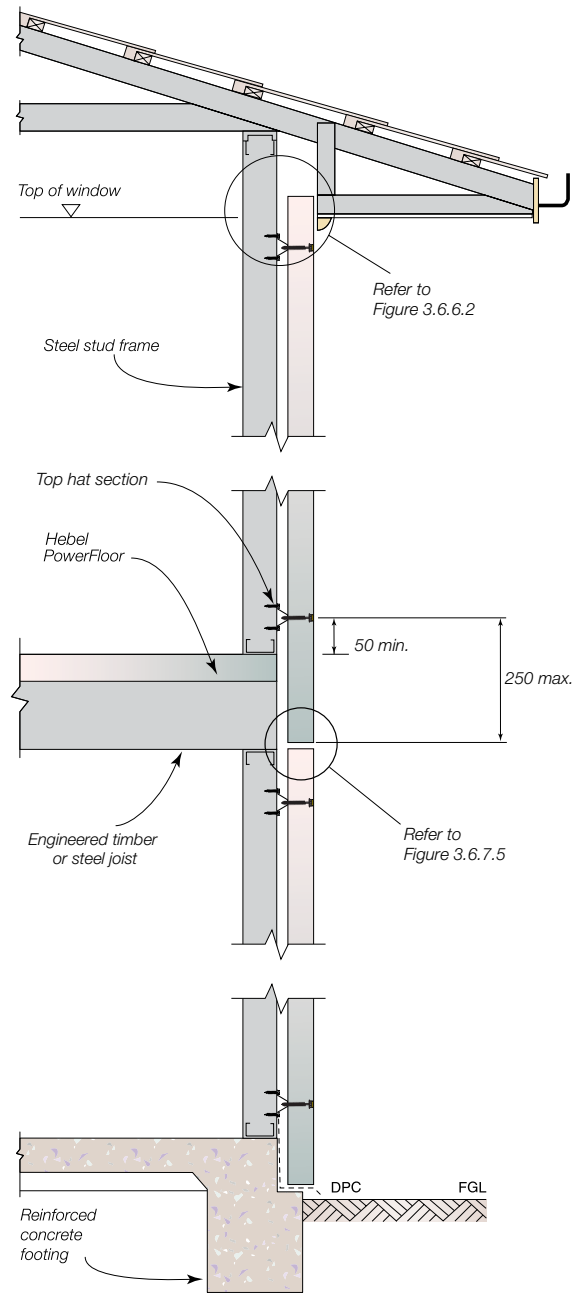

Figure 3.6.2.5 two storey construction – steel frame section or engineered joists with $\leq 1\%$ shrinkage



NOTES:

1. Lower storey Hebel PowerPanel^{XL} Panels are supported at the base on concrete slab edge.

3.6.3 TWO STOREY ADDITION DETAILS

Figure 3.6.2.6 Hebel external wall cladding detail extending above first floor

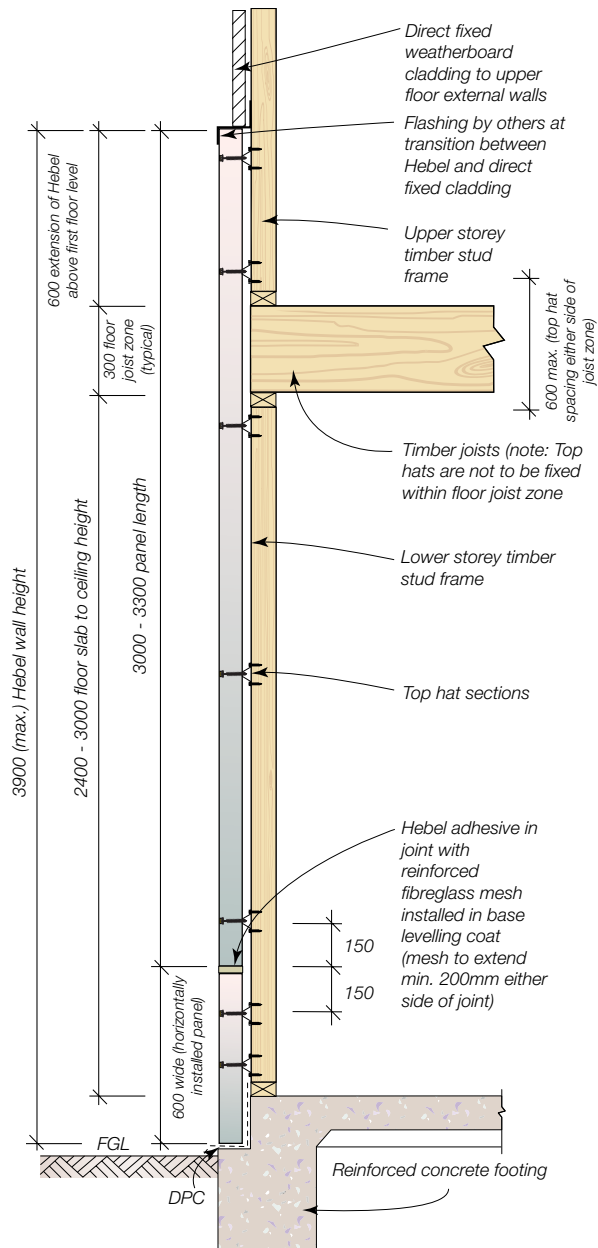

Note: 600mm wide (horizontally installed panel) can be installed above full length panel provided Hebel adhesive in joint with reinforced fibreglass mesh is installed in base levelling coat (mesh to extend min. 200mm either side of joint)

Figure 3.6.3.1 Two storey addition – isometric view detail

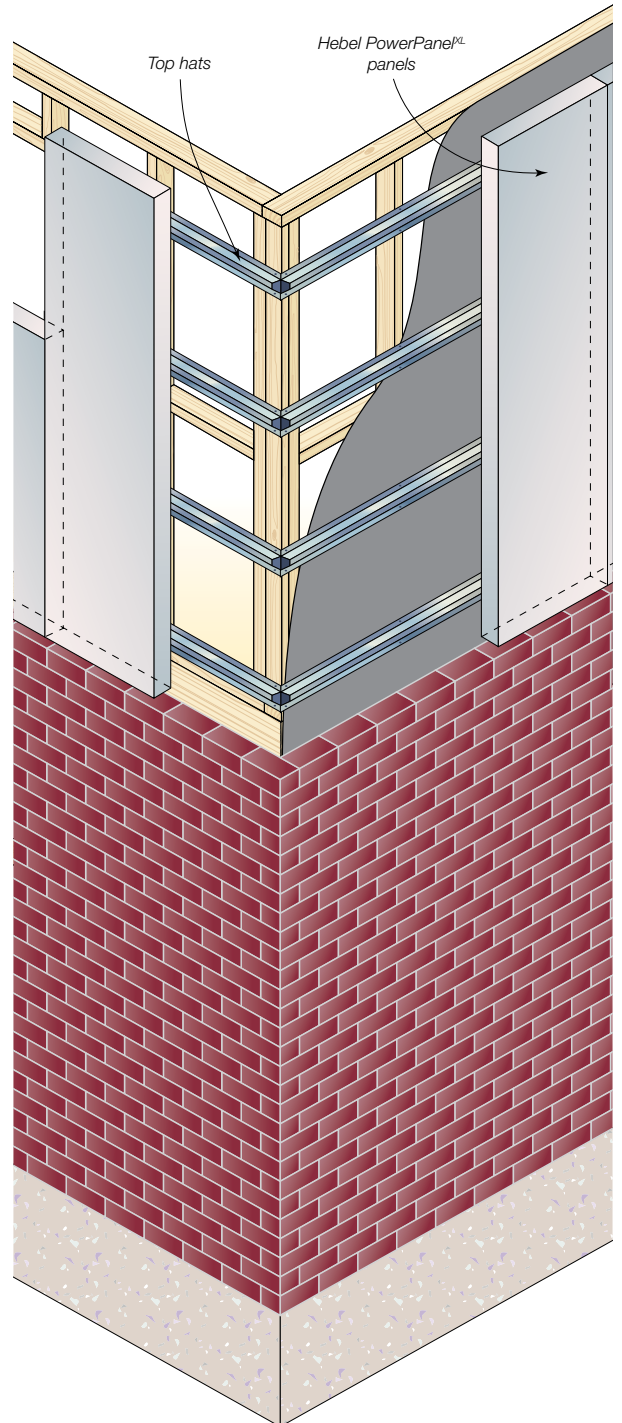

Figure 3.6.3.2 Two storey additions – typical section with brick veneer below

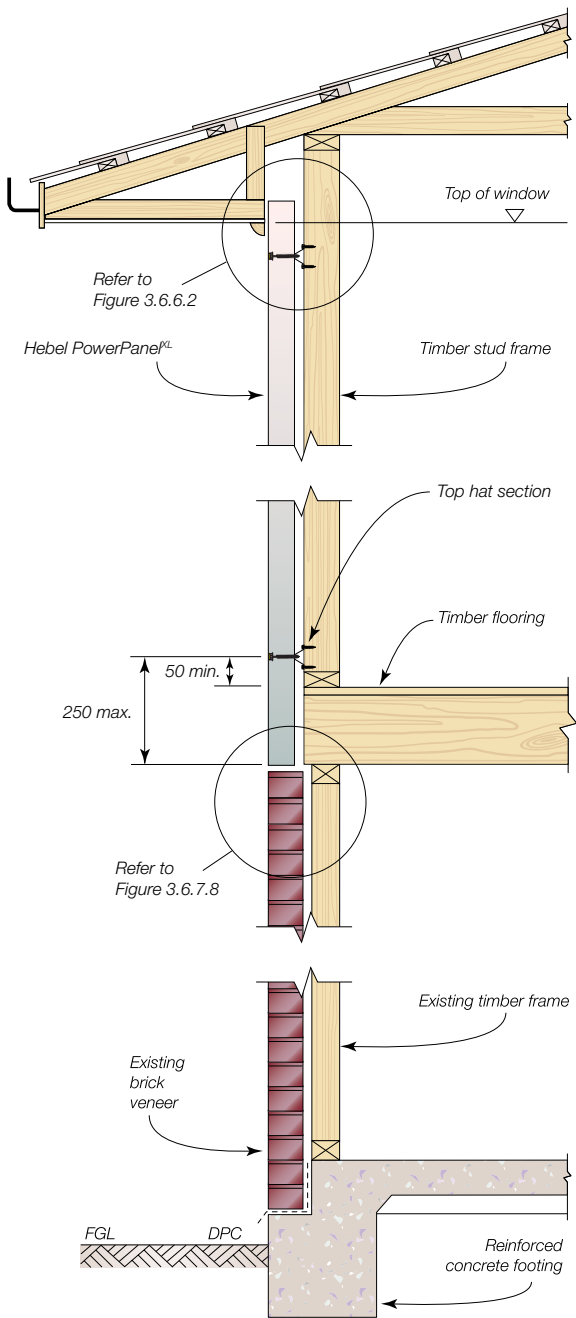
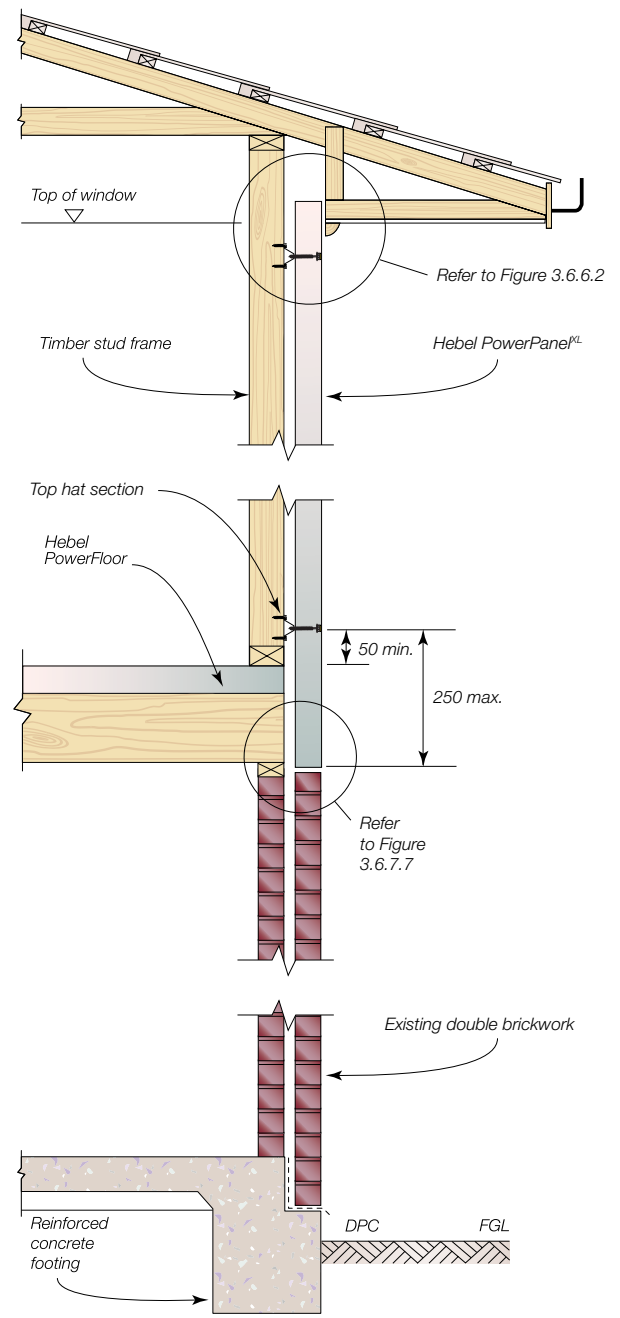

Figure 3.6.3.3 Two storey additions – typical section with double brick below



NOTES:

1. Minimum 4 top hats required for panels that are suspended off the frame. Refer to Table 1.2.4 of this guide.

3.6.4 FIXING & INSTALLATION DETAILS

Figure 3.6.4.1 Hebel PowerPanel^{XL} External Wall System fixing detail (Achieves FRL 90/90/90 when installed as part of the wall system. See Section 2.2)

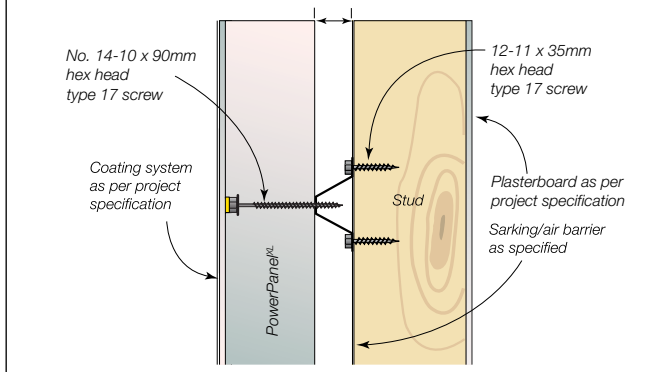

NOTE:
When positioning the stud frames allow 5-7mm extra cavity width for the sheet bracing between top hat and timber stud.

Figure 3.6.4.2 Hebel PowerPanel^{XL} Zero Boundary Wall System fixing detail (Achieves FRL 90/90/90 when installed as part of the wall system. See Section 2.2)

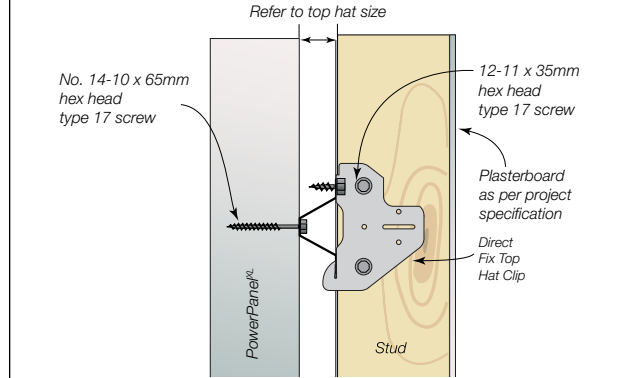

IMPORTANT: Top hat clip is fixed on the left hand side of the stud (when looking from inside to the outside of the building) except at the last stud, only, when the clip may be installed upside down.

Installing the clip upside down i.e. where the screw fixing from the clip to the top hat is at the bottom flange of the top hat, will be acceptable provided that:

- A: The upside down clip is fixed on the right hand side of the stud (when looking from the inside to the outside of the building)
- B: The upside down clip installation is to the last stud of a wall run (only), such that the spacing between the last and second last studs is no greater than 600mm,
- C: The top hat is continuous in this region for a minimum of two spans i.e. top hat extends across two stud spacings,
- D: In all other locations, clips are to be installed to the left hand side of the stud with the screw fixing to the top side of the clip i.e. into the top flange of the horizontal top hat.

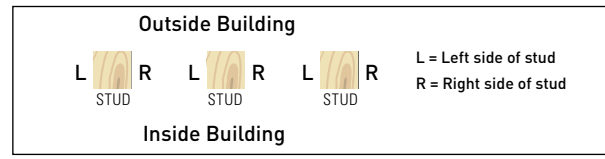
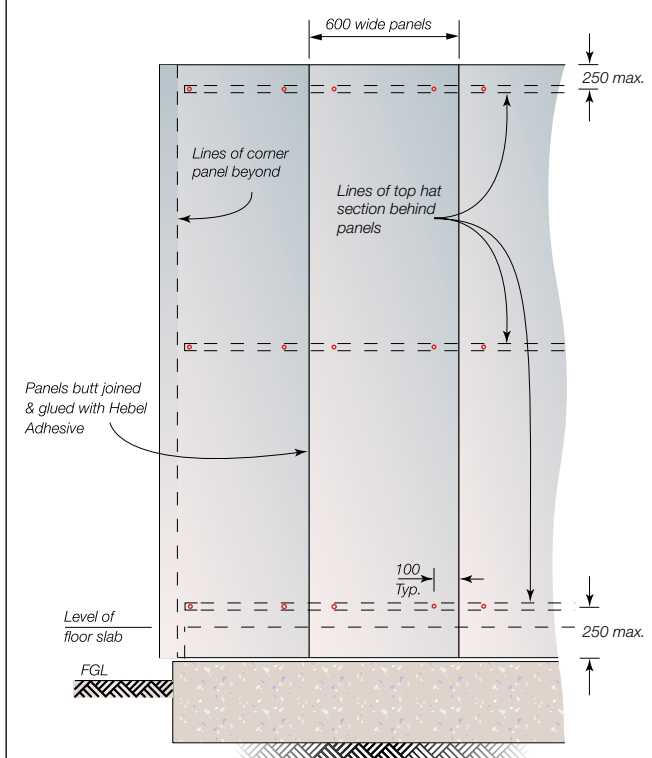
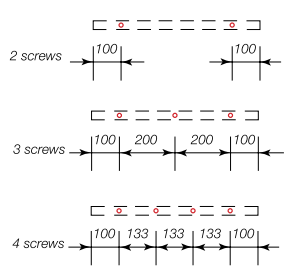

Figure 3.6.4.3 Screw layout drawing



PowerPanel^{XL} panel setout – elevation view



Screw layout

Figure 3.6.4.4 Hebel PowerPanel^{XL} zero Boundary Wall System (Achieves FRL 90/90/90 when installed as part of the wall system. See Section 2.2)

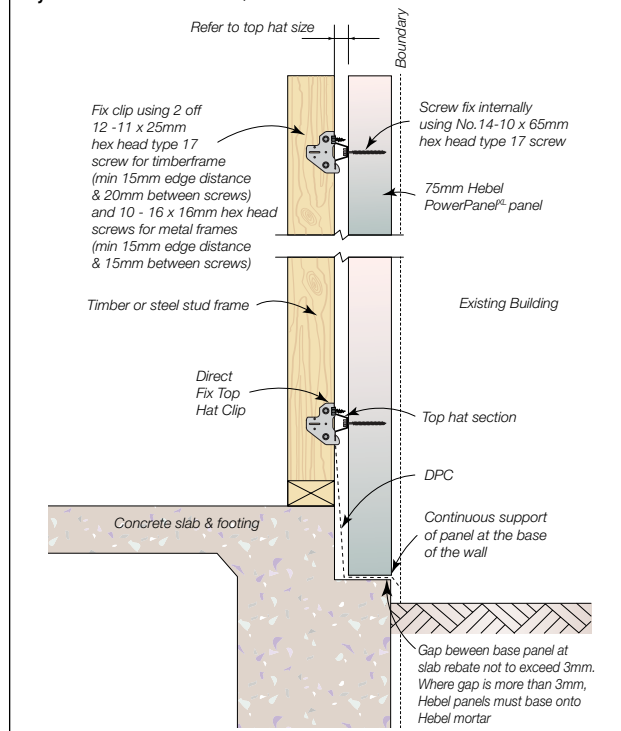

3.6.5 FOOTING JUNCTION DETAILS

Figure 3.6.5.1 Junction to shallow concrete footing

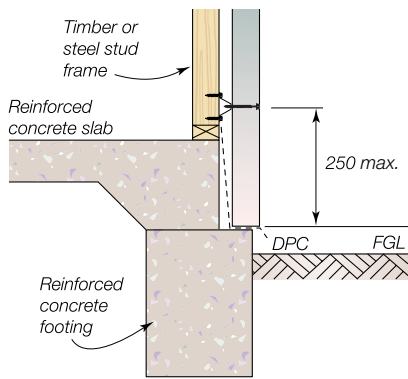

Figure 3.6.5.2 Junction to deep concrete edge beam

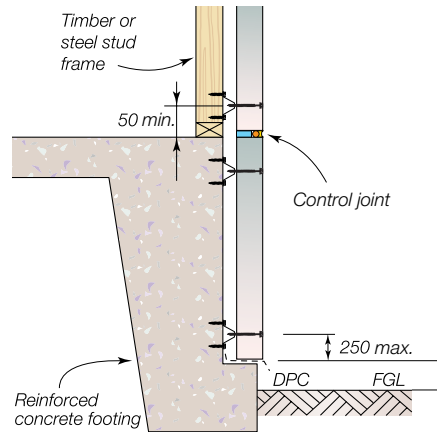

Figure 3.6.5.3 Junction to masonry earth retaining wall

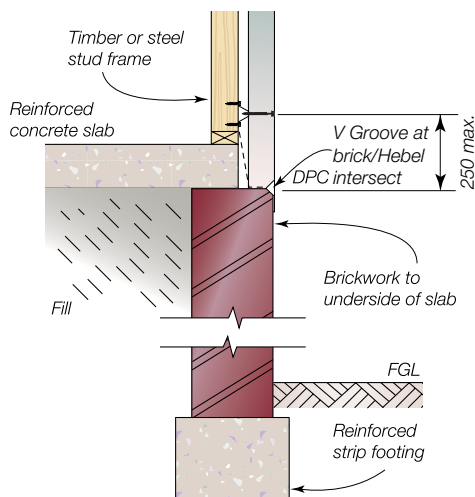
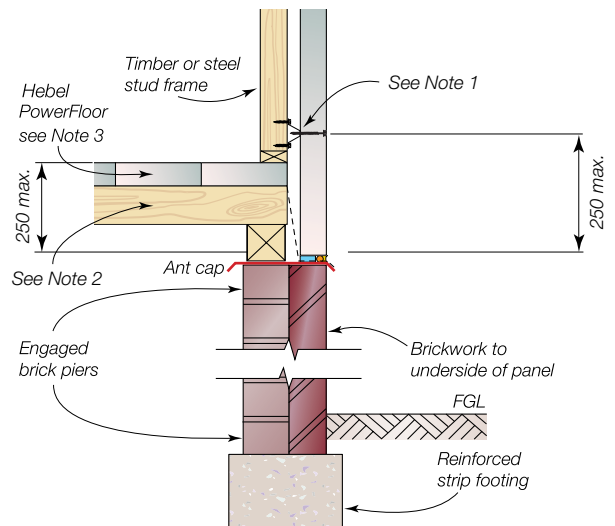

Figure 3.6.5.4 Junction to masonry dwarf wall



NOTES:

1. Do not fix top hat to floor joists.
2. If non-shrink floor joists are used, gap may be reduced or eliminated. Seek further technical advice from the framing manufacturer.
3. Refer to CSR Hebel for Hebel PowerFloor details.
4. Refer AS 3660 for termite protection.
5. When fixing top hats to concrete, contact the fixing manufacturer for details.
6. Refer to Table 1.2.6 for top hat requirements for deep concrete edge beam applications.

Figure 3.6.5.5 Junction to existing piers/stumps

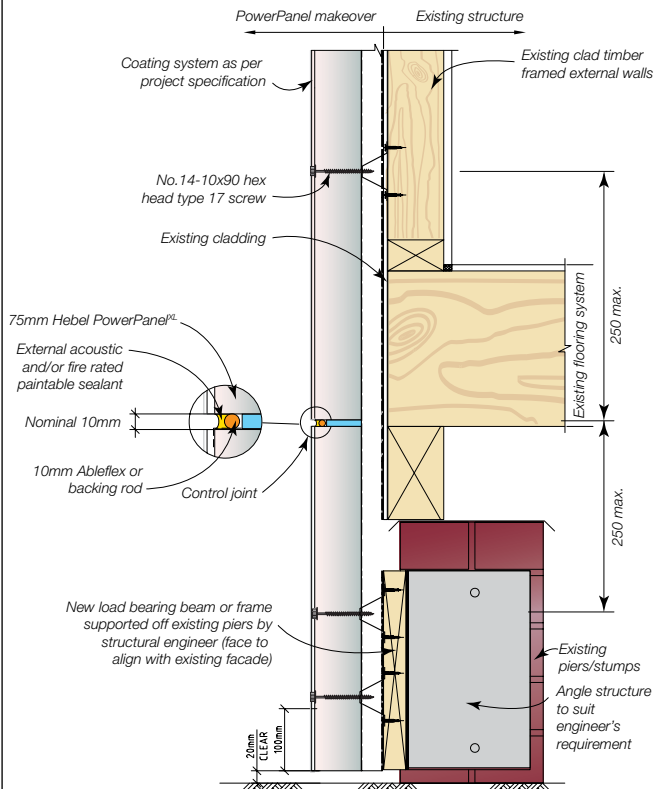

NOTES:

1. Refer to Tables 1.2.3 to 1.2.5 for top hat requirement for suspended applications
2. This detail is not considered to achieve a fire rating level
3. This slab edge detail does not comply with the termite visible inspection zone requirements. Alternate termite management systems must be used when selection this detail. It is the responsibility of the builder to provide a suitable physical or chemical barrier in accordance with AS 3660.

Figure 3.6.5.6 Base detail suspended floor – pier connection

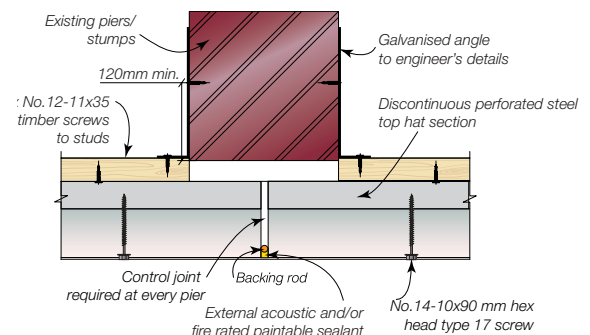
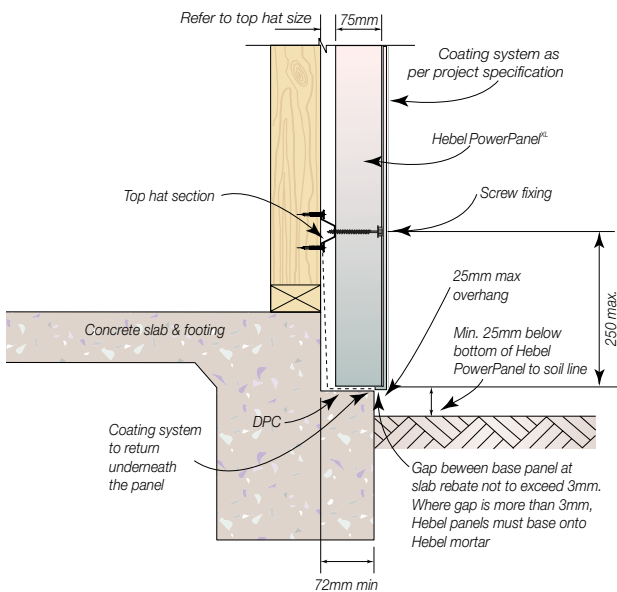

Figure 3.6.5.7 Junction to shallow concrete edge beam (Achieves FRL 180/180/180 when installed as part of the wall system. See Section 2.2)



NOTES:

1. All garden beds and /or finished soil line must remain a minimum of 25mm below the bottom of the finished rendered wall.
2. This slab edge detail does not comply with the termite visible inspection zone requirements. Alternate termite management systems must be used when selection this detail. It is the responsibility of the builder to provide a suitable physical or chemical barrier in accordance with AS 3660.

Figure 3.6.5.8 Junction to steel angle

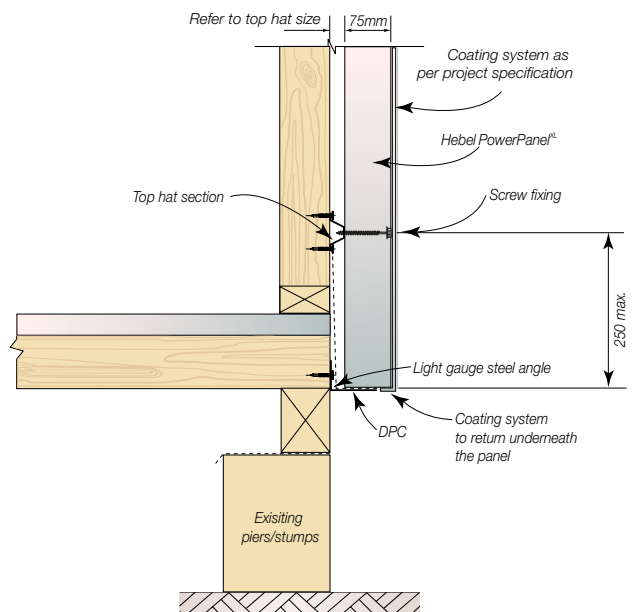

NOTES:

1. This detail is not considered to achieve a fire rating level.
2. The light gauge steel angle is for the purpose of closing the cavity at the base of the wall.

Figure 3.6.5.9 Junction to Hebel below finish ground

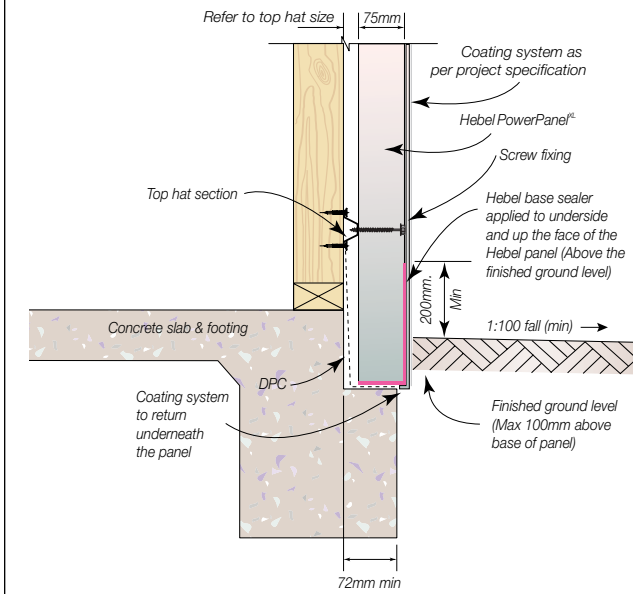
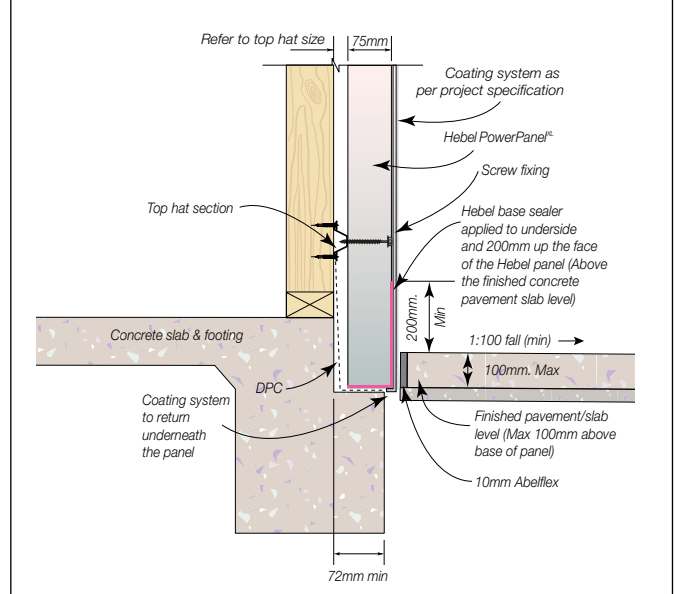

Figure 3.6.5.10 Junction to Hebel below concrete pavement slab



NOTES:

1. This slab edge detail does not comply with the termite visible inspection zone requirements. It is the responsibility of the builder to ensure chemical barrier in accordance with AS3660 is installed or other suitable termite protection system is adopted.
2. Hebel PowerPanel base must be coated with Hebel Base Sealer prior to installation.
3. Hebel Base Sealer to be applied min. 200mm finished ground level.

3.6.6 WALL JUNCTION DETAILS & SECTIONS

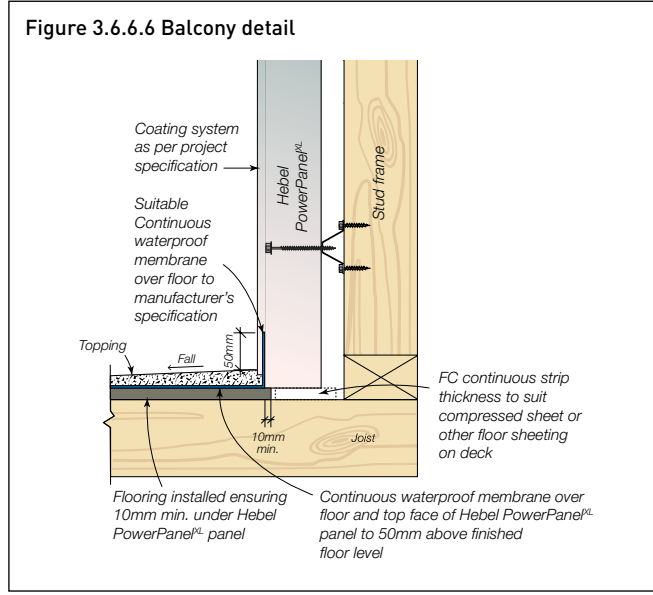
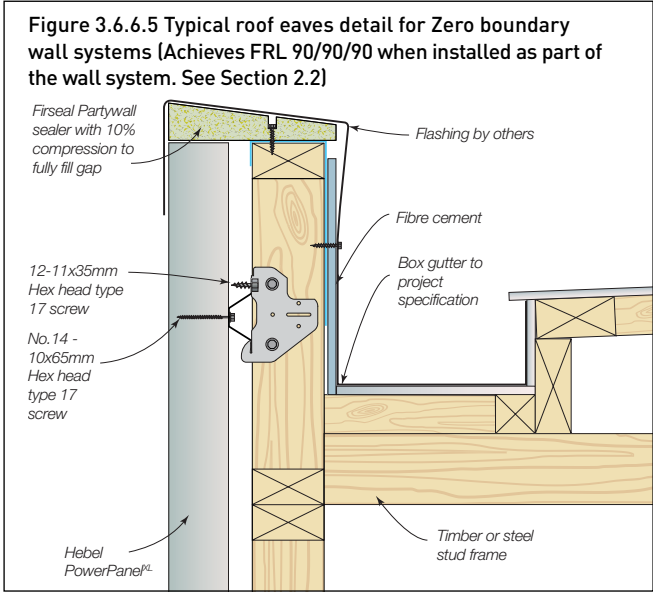
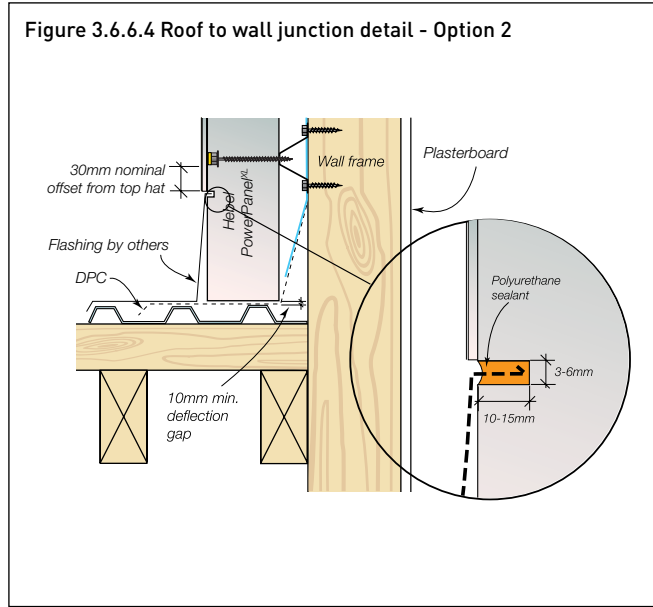
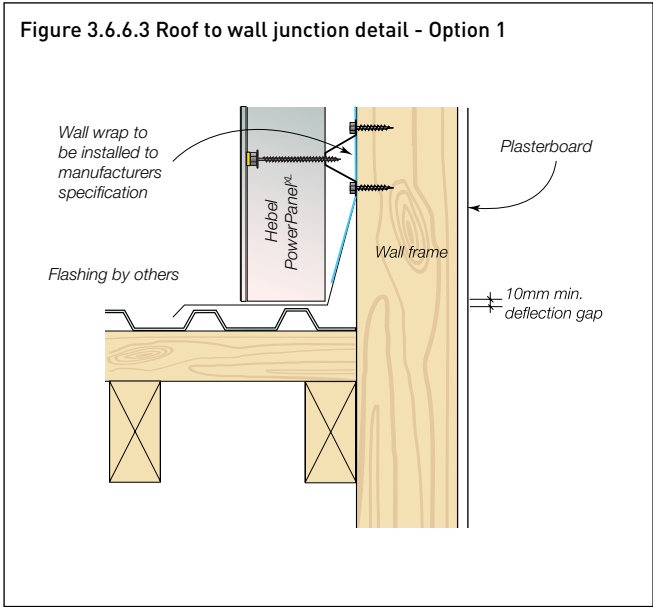
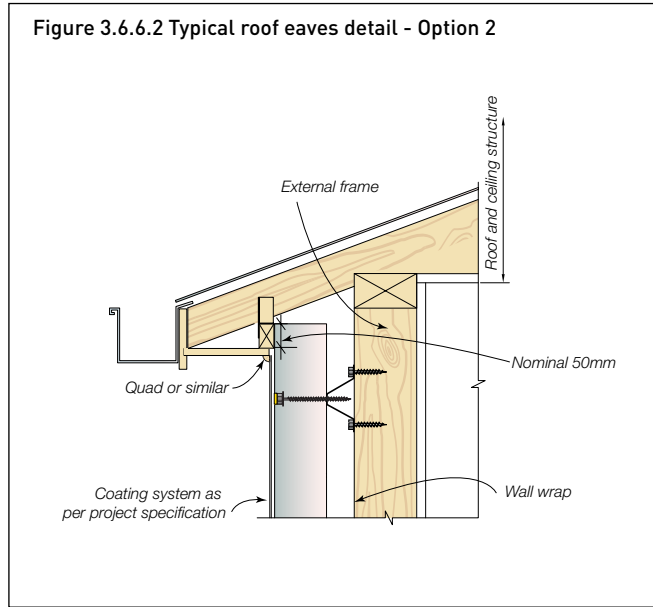
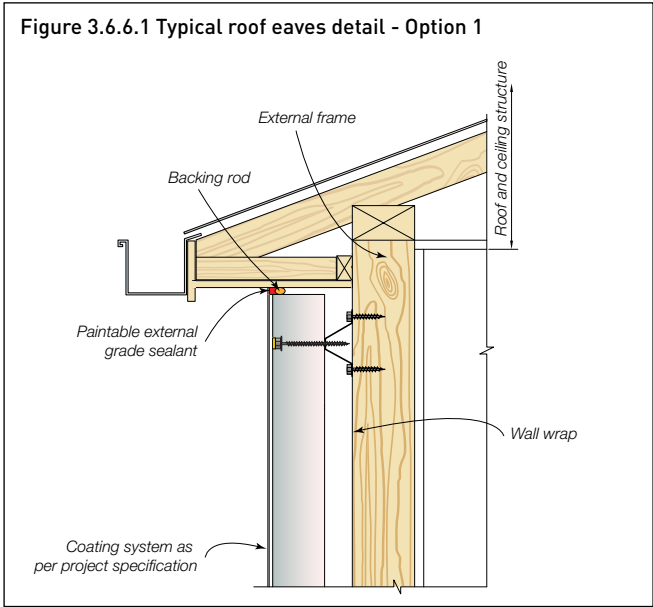

Figure 3.6.6.7 Zero boundary wall detail to Hebel PowerPanel^{XL} external wall system (Achieves FRL 90/90/90 when installed as part of the wall system. See Section 2.2)

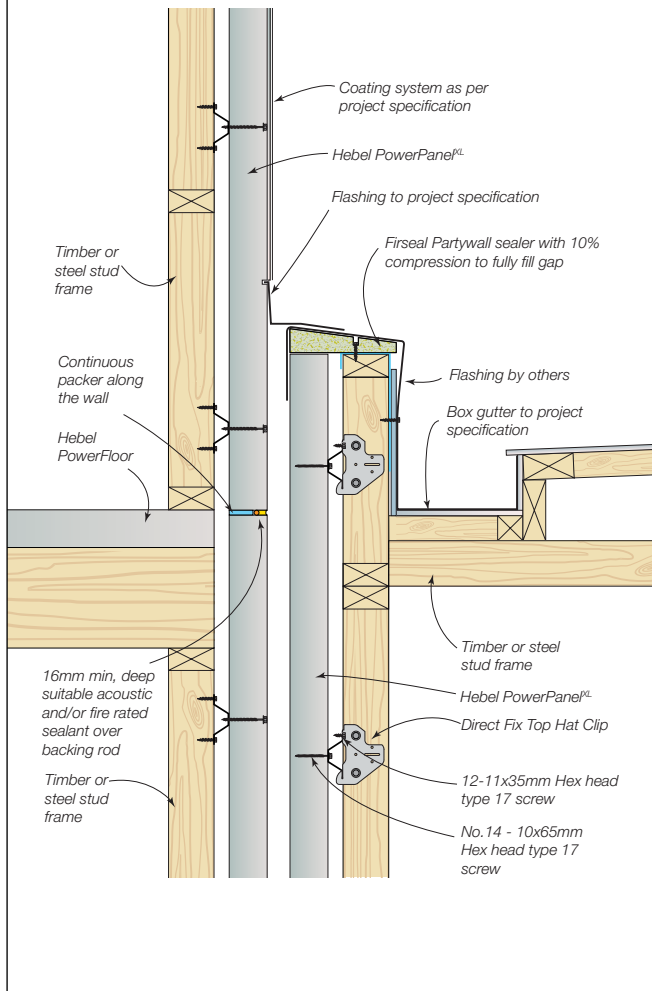

Figure 3.6.6.8 Zero boundary wall detail to brick veneer (Achieves FRL 90/90/90 when installed as part of the wall system. See Section 2.2)

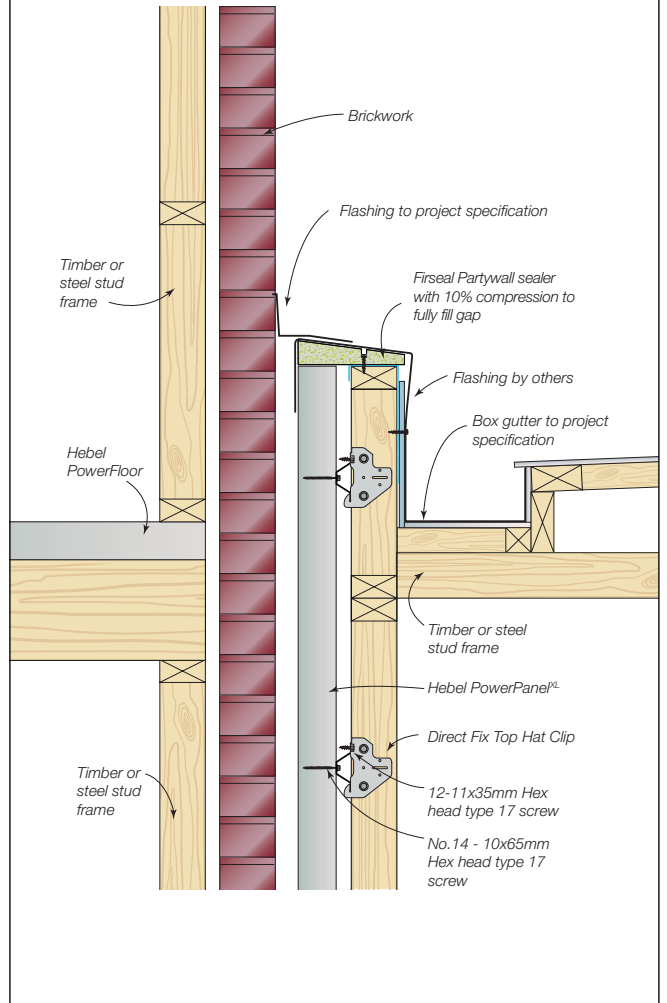
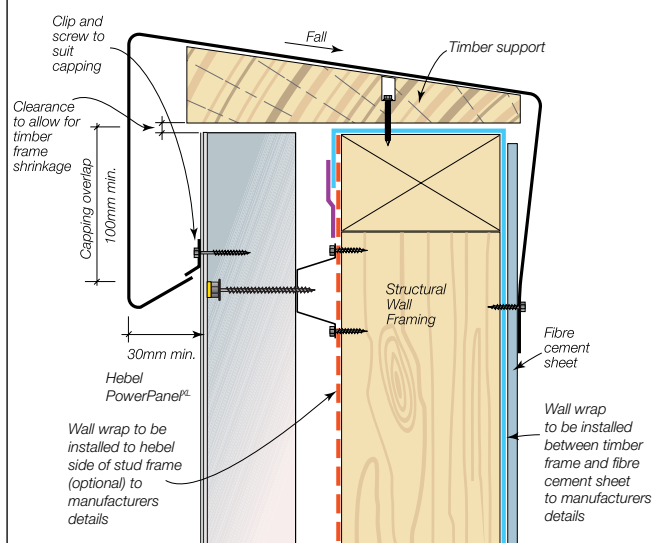
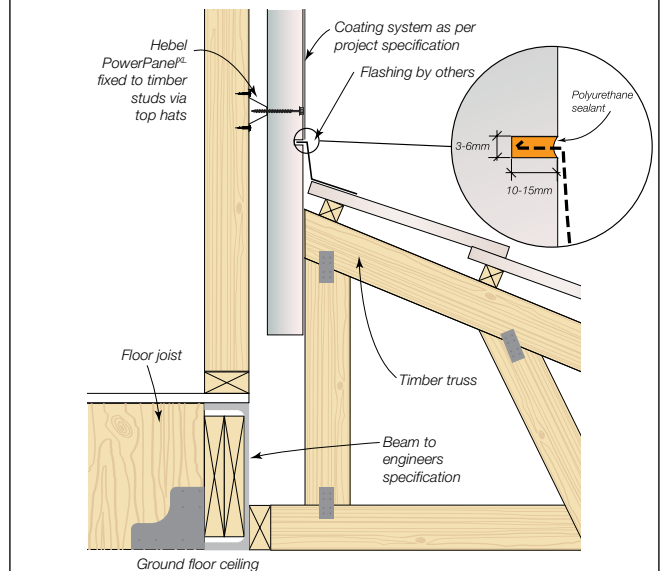

Figure 3.6.6.9 Parapet capping



NOTE:
Parapet capping shall be designed and fastened in accordance with SAA – HB39 2015 – Installation Code for Metal Roofing and Wall Cladding. Stop ends shall be incorporated to all flashings.

Figure 3.6.6.10 Hebel to pitched roof junction



NOTE: Hebel PowerPanel^{XL} panels are suspended from frame. Refer to tables 1.2.4 and 1.2.5 of this guide for design.

Figure 3.6.6.11 Gable end wall detail

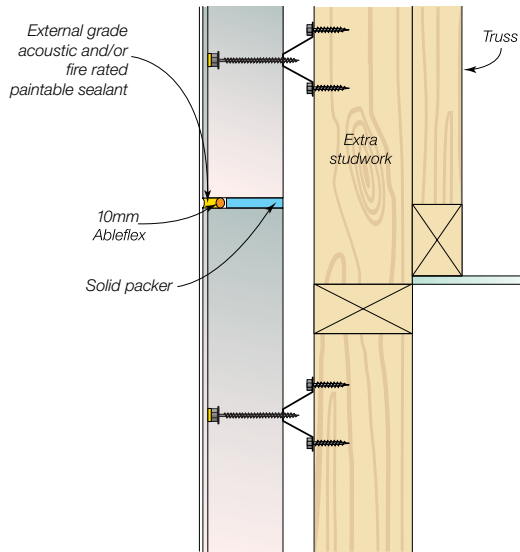

Figure 3.6.6.12 Gable end wall detail – lintel panel over window

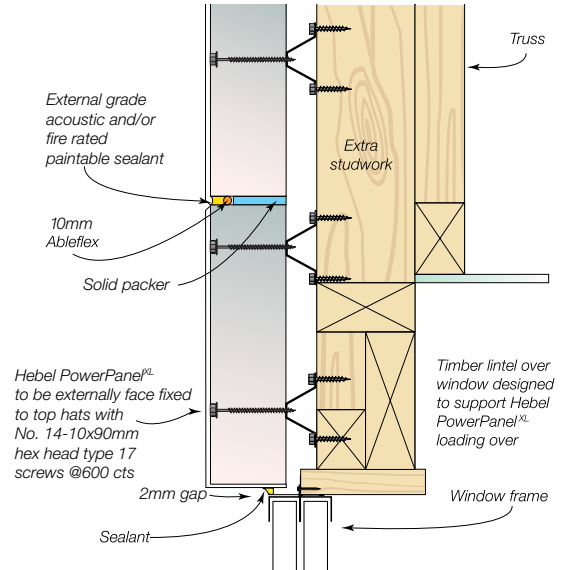

Figure 3.6.6.13 Beam penetration detail

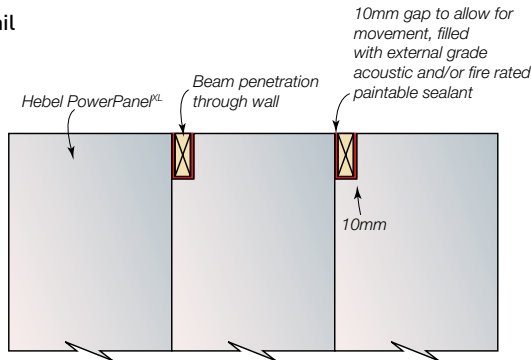
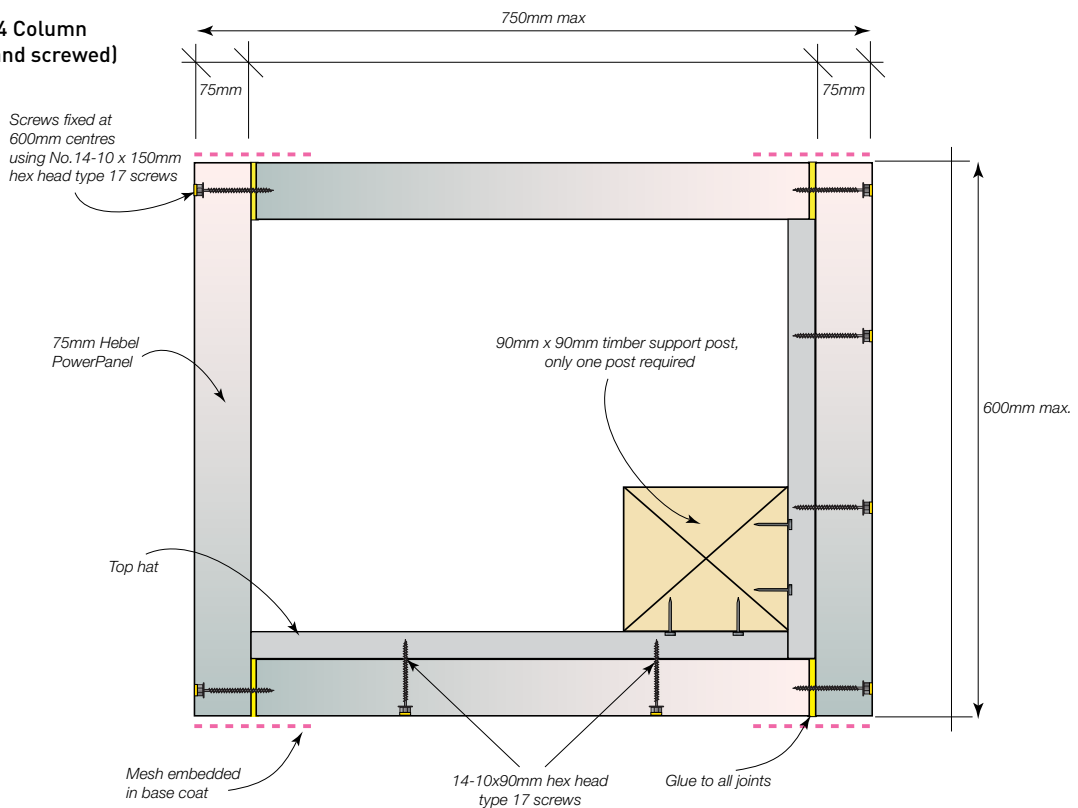

Figure 3.6.6.14 Column detail (glued and screwed)



3.6.7 CONTROL JOINTS

The following information provides the necessary rules for control jointing when installing the Hebel PowerPanel^{XL} External Wall System:

- Refer section 1.3 for vertical control joint spacing (based on site classification)
- Vertical control joints required at external and internal corners
- Vertical control joints required above and below all doors, including sliding and garage doors
- Vertical control joints required at the position where a wall changes height by more than 20% e.g a vertical control joint is required when wall height changes from 2700mm to ≥ 3240 mm.
- Horizontal control joints required at every horizontal floor junction
- Horizontal control joints required at a maximum height of 3.9m.

For openings < 2450mm in width

- Control joint not required. If the straight joint that extends above or below the window jamb is less than 600mm long, a control joint or a glued and meshed joint is required.

For openings ≥ 2450 mm and < 3600mm wide

- Control joint required to at least one side of the opening (i.e. above and below the opening). If the straight joint that extends above or below the window jamb is less than 600mm long a control joint or a glued and meshed joint is required to the opposite side of the opening.

For openings ≥ 3600 mm in width

- Control joint required to both sides of the opening (i.e. above and below the opening).

NOTES:

1. The minimum lintel panel height above windows is 270mm.
2. Footing and slab design to comply with AS 2870.
3. Vertical control joints are not required to align between storeys of the building and can be terminated at the horizontal control joint located within the upper storey floor framing structure zone/depth.
4. The PowerPanel^{XL} panels can be installed directly beside window or door openings (retaining a minimum 2-3mm gap between window jamb and panel) such that the control joint is only installed above and below the opening to the required width, negating the need to provide the width of the control joint directly beside the window or door. The 2-3mm gap is also required at the head of the window or door to the head panel.

Figure 3.6.7.1 Internal corner (Achieves FRL -/120/120 when installed as part of the wall system. See Section 2.2)

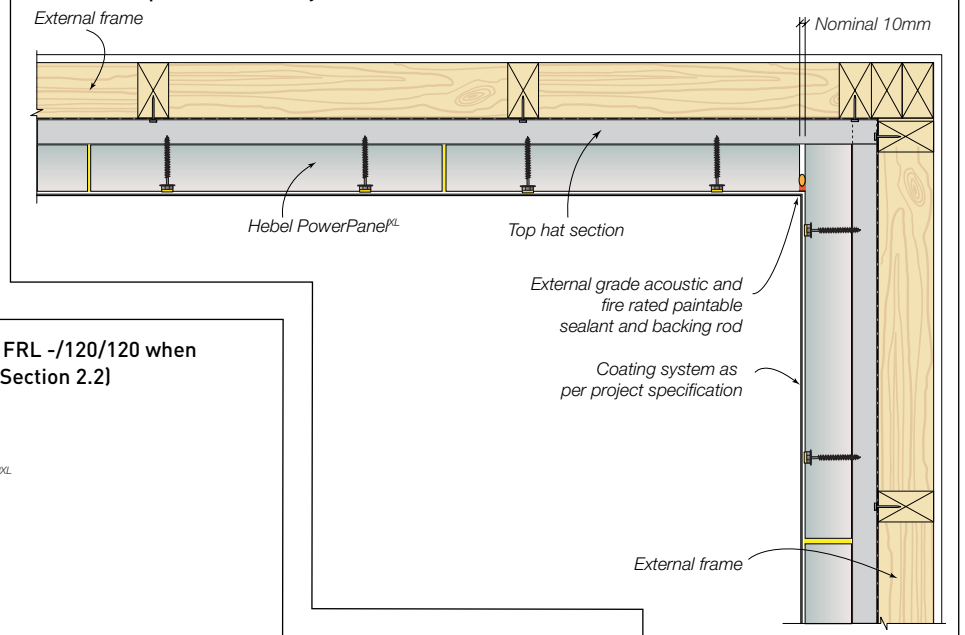

Figure 3.6.7.2 External corner (Achieves FRL -/120/120 when installed as part of the wall system. See Section 2.2)

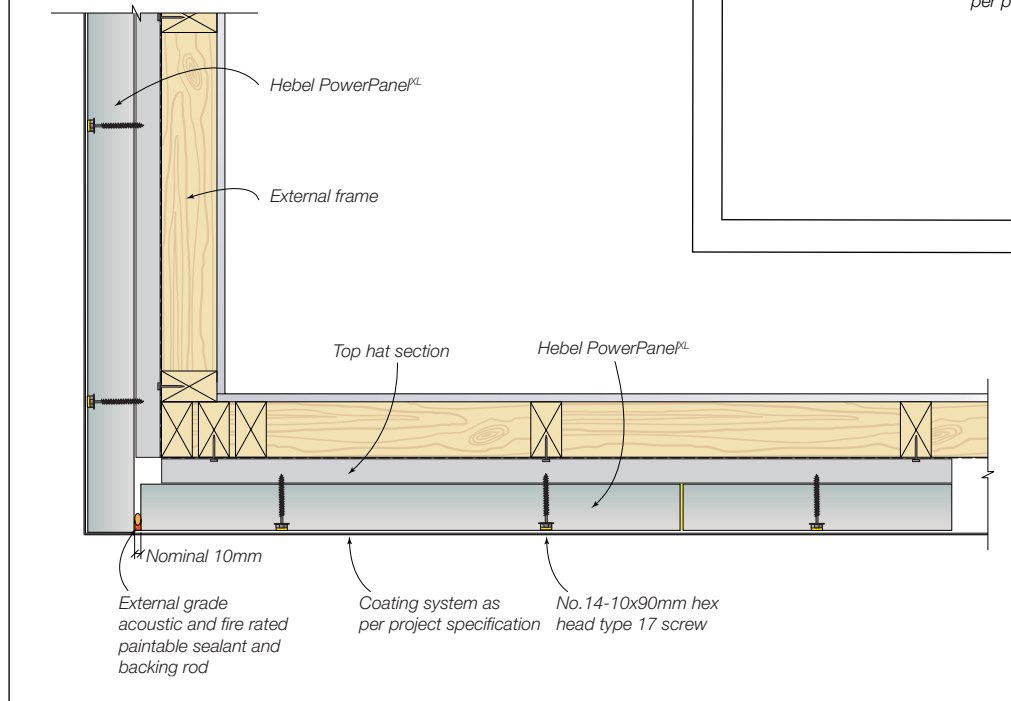

Figure 3.6.7.3 Typical detail for control joints positioned on corner

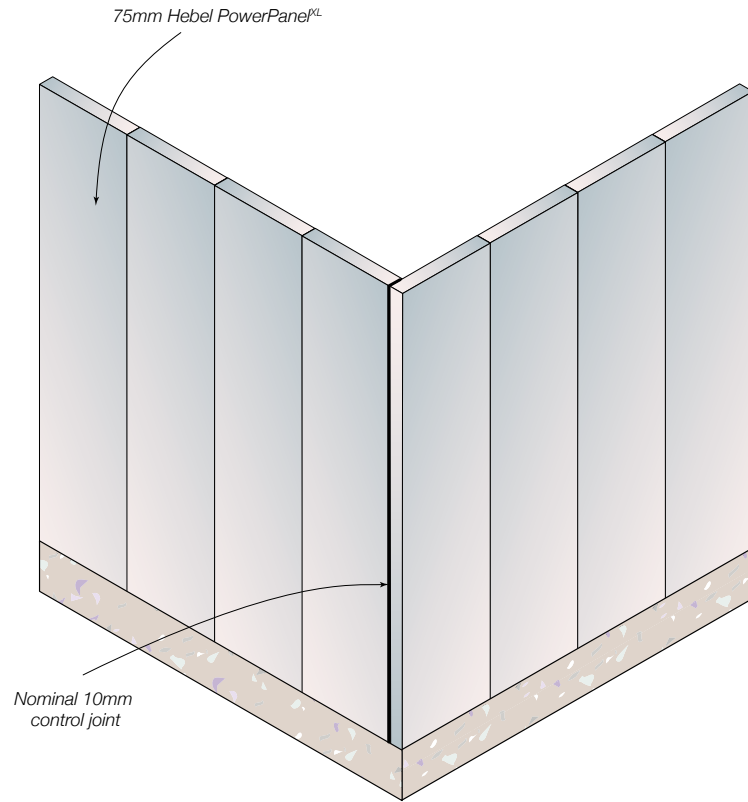

Figure 3.6.7.4 Typical detail for control joints positioned away from a corner

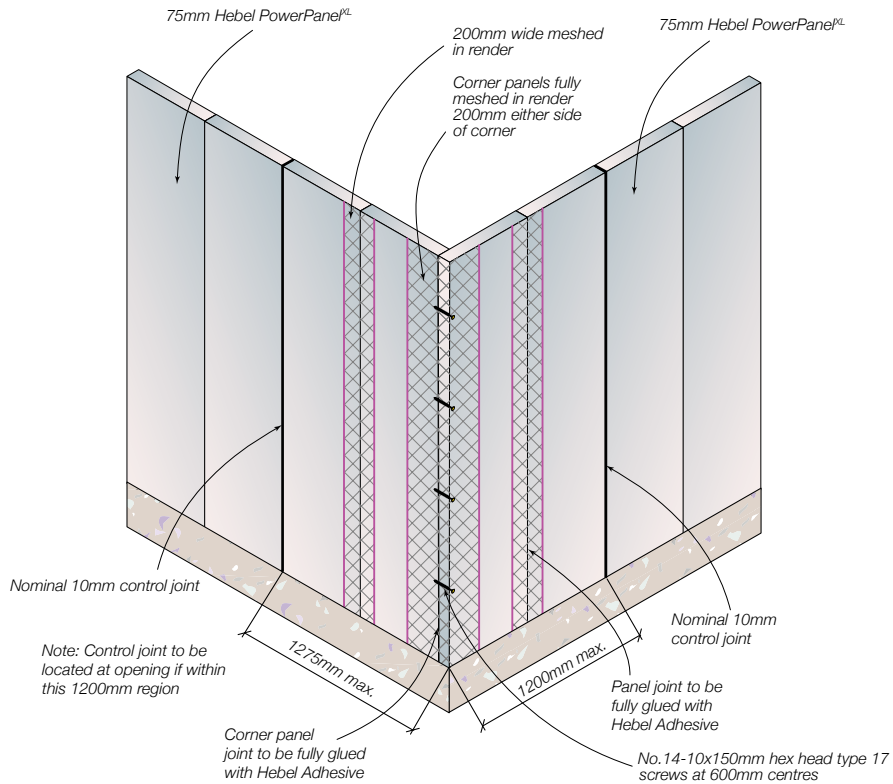

Figure 3.6.7.5 Typical horizontal control joint – engineered timber or steel frame (Achieves FRL -/120/120 when installed as part of the wall system. See Section 2.2)

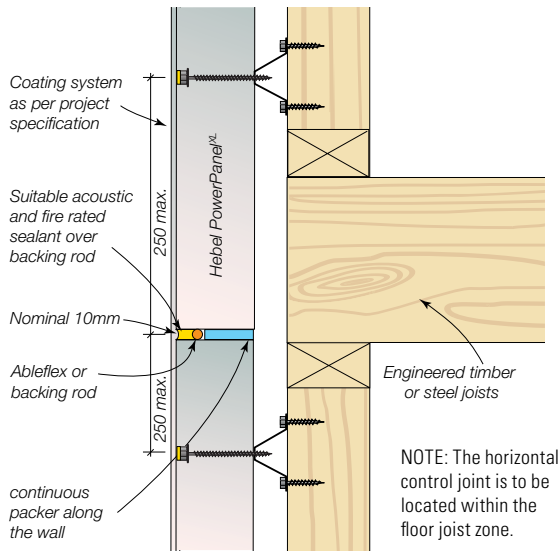

Figure 3.6.7.6 Horizontal control joint – Cavity brickwork to Hebel PowerPanelXL

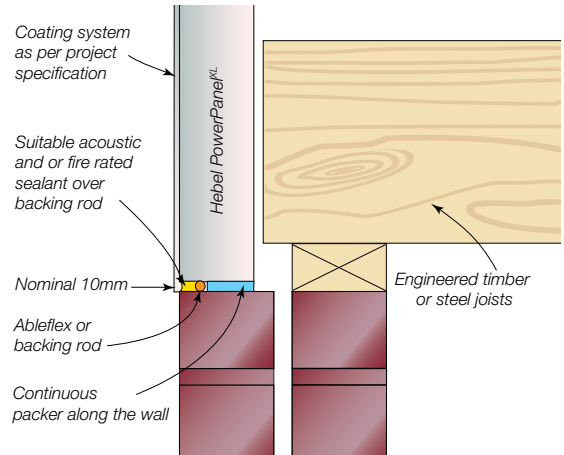

Figure 3.6.7.7 Horizontal control joint – Brick veneer to Hebel PowerPanelXL - Option 1

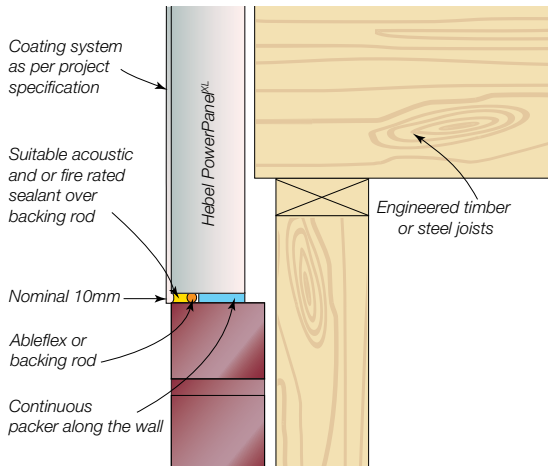

Figure 3.6.7.8 Horizontal control joint – Brick veneer to Hebel PowerPanelXL - Option 2

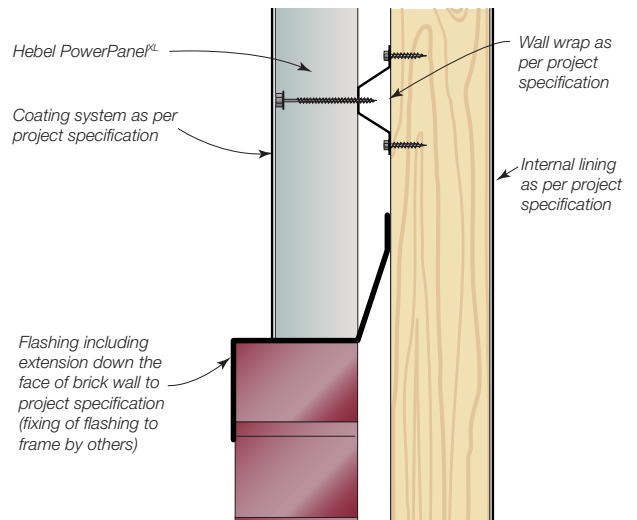

Figure 3.6.7.9 Typical vertical control joint (Achieves FRL -/120/120 when installed as part of the wall system. See Section 2.2)

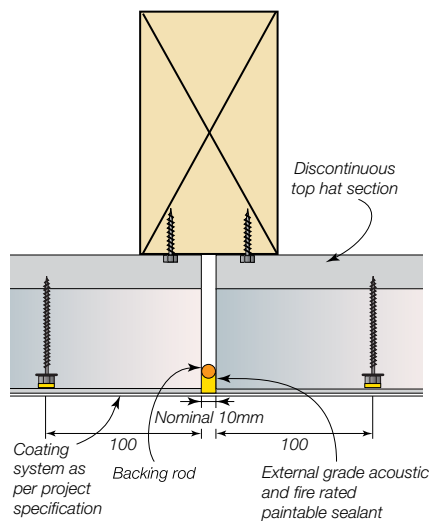

Figure 3.6.7.10 Typical vertical control joint with double studs (Achieves FRL -/120/120 when installed as part of the wall system. See Section 2.2)

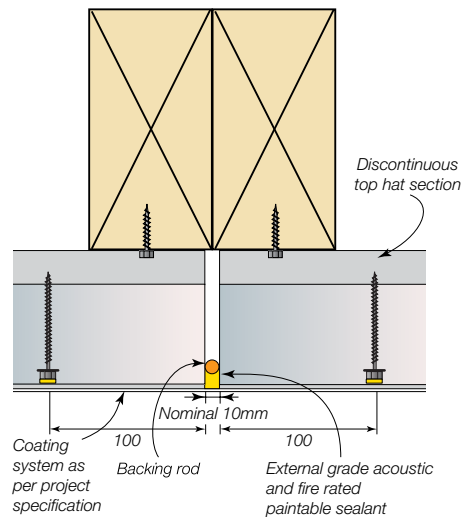

Figure 3.6.7.11 Control joint - aligned top hats on double stud

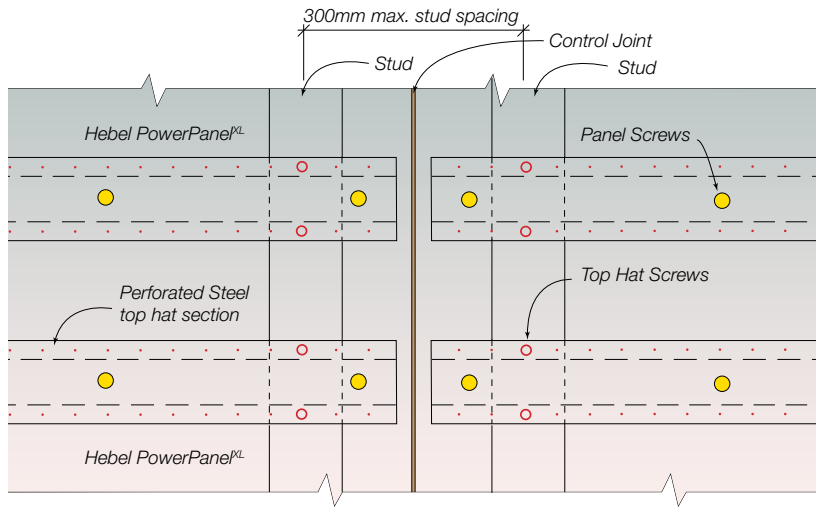

Figure 3.6.7.12 Control joint - discontinuous top hats on a single stud

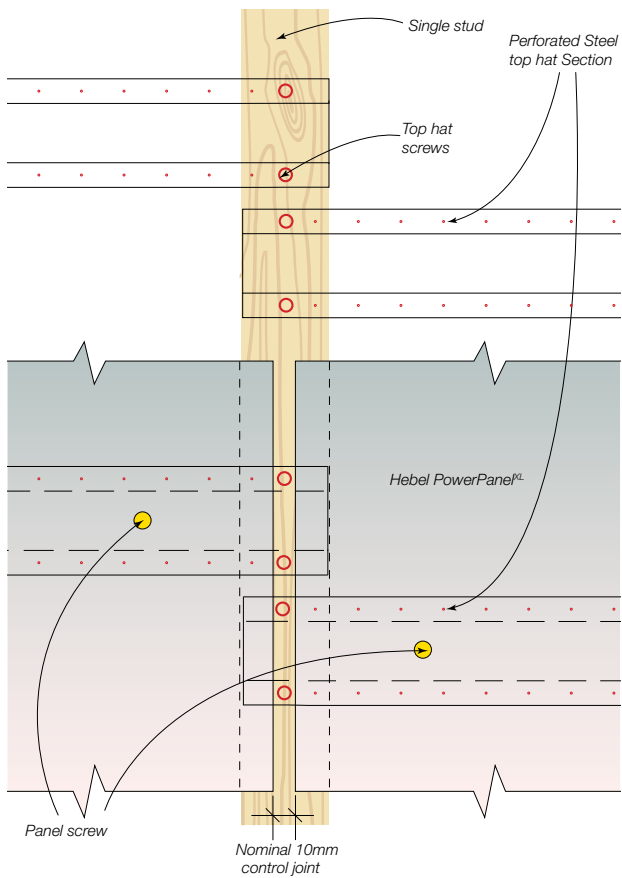
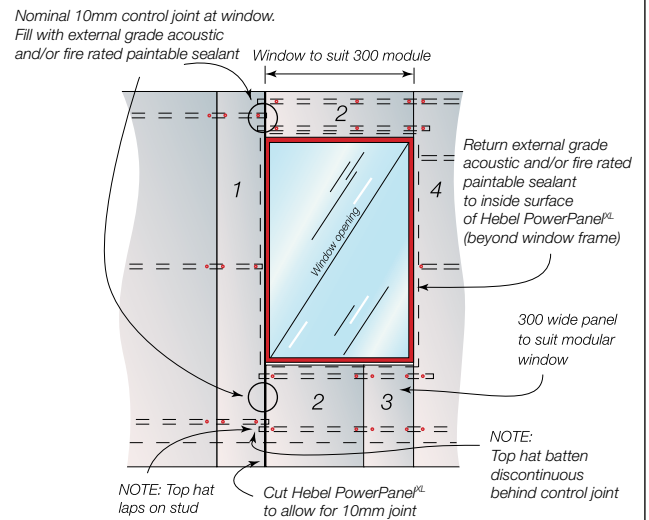

Figure 3.6.7.13 Typical window control joint detail - lintel over



NOTE:
The installation sequence of the PowerPanel^{XL} panels around the openings should be followed as numbered if there is no control joint at the opening, to maintain glue thickness on the edge of the panel.

3.6.8 DOOR & WINDOW DETAIL

Figure 3.6.8.1 Typical window sill detail – aluminium window frame – Option 1

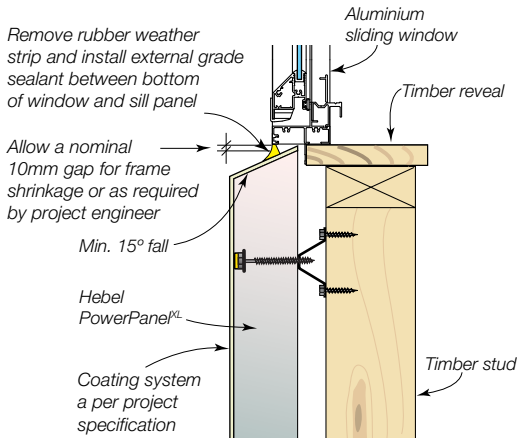

NOTE: Include suitable backing rod and sealant for 5-10mm gaps.

Figure 3.6.8.2 Typical window sill detail – aluminium window frame – Option 2

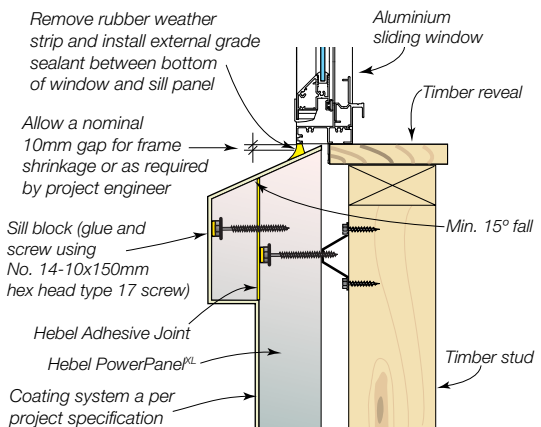

NOTE: Include suitable backing rod and sealant for 5-10mm gaps.

Figure 3.6.8.3 Typical window sill detail – aluminium window frame – Option 3

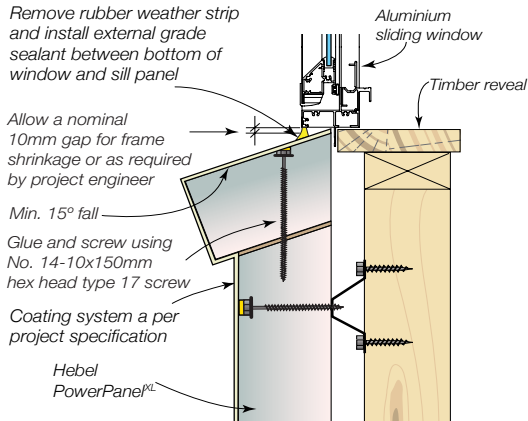

NOTE: Include suitable backing rod and sealant for 5-10mm gaps.

Figure 3.6.8.4 Header detail

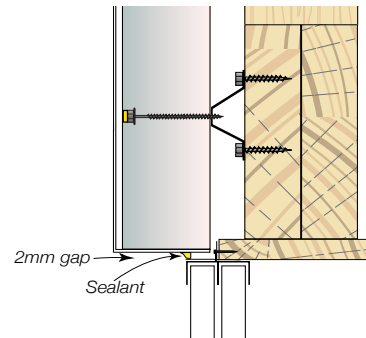

NOTE: Drainage of window and door sills, in either aluminium or timber, should be directed to the outside of the building, on top of the window sill.

NOTE: CSR Hebel recommends the removal of the rubber weather strip at the window sill prior to applying external grade sealant between the bottom of the window sill and panel. Windows shall be caulked around all sides to ensure that the system remains sealed and not allow water ingress into the cavity. The installation of any alternative details shall be the responsibility of the builder to provide supporting evidence that it meets the requirements of a sealed system and maintains a dry cavity.

Figure 3.6.8.5 Garage head detail

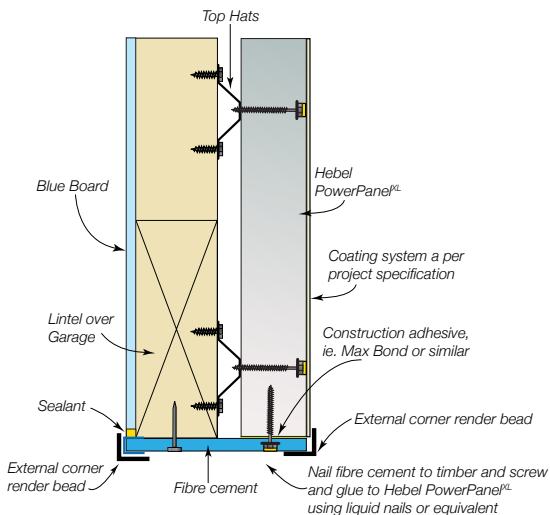

Figure 3.6.8.6 Garage door – jamb detail – Option 1

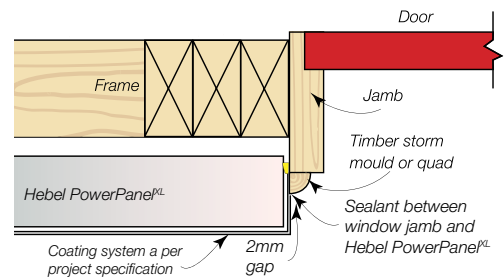
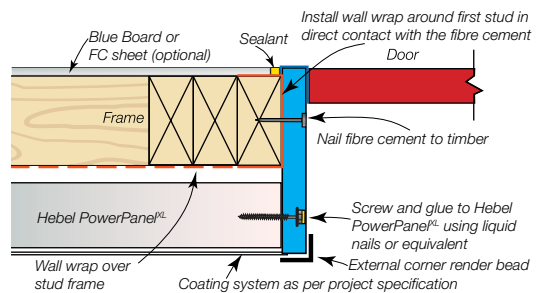

Figure 3.6.8.7 Garage door – jamb detail – Option 2



NOTE: Fibre cement reveal must extend the full height of the wall and finish at the top of the concrete slab with no gap, so as to ensure the system remains face-sealed.

Figure 3.6.8.8 Sliding door sill detail – Concrete sill < 270mm

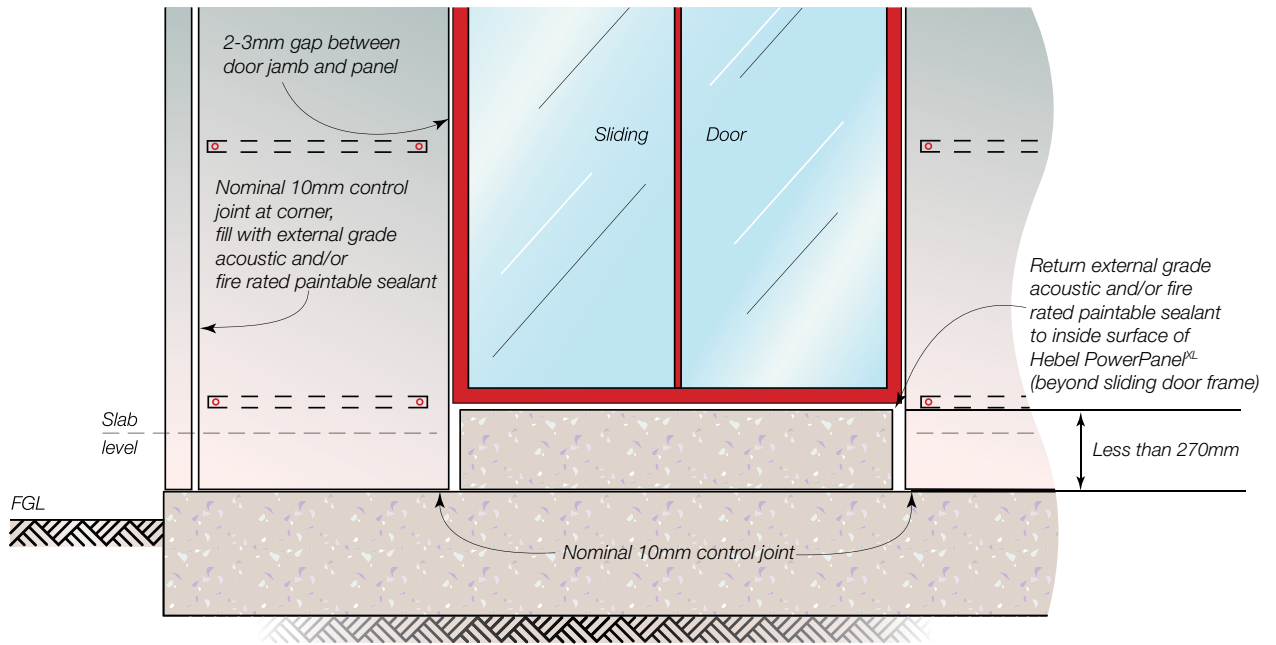
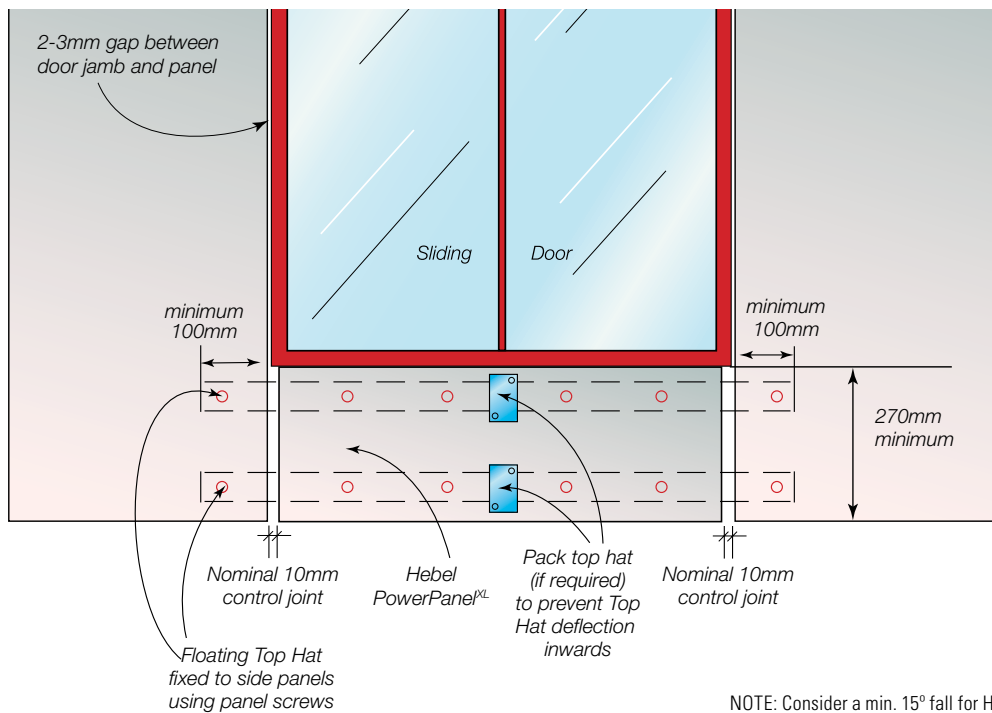
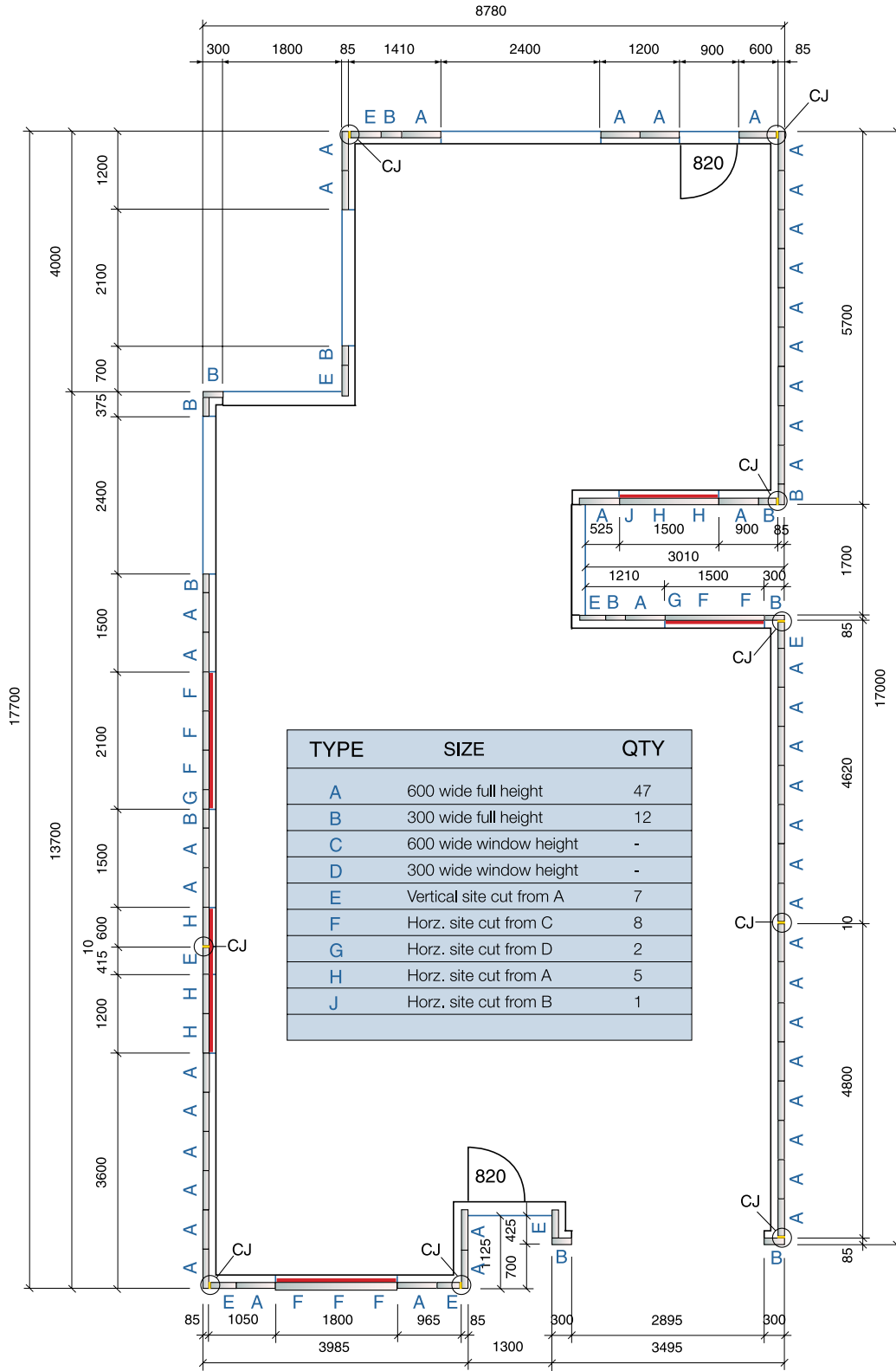

Figure 3.6.8.9 Sliding door sill detail – PowerPanel^{XL} sill > 270mm



3.6.9 MISCELLANEOUS DETAIL

Figure 3.6.9.1 Panel layout drawing – Plan view



NOTES:

1. At corners, PowerPanel^{XL} panels can be laid out at 300mm multiples in one direction and 300mm multiples + 85mm in the other direction
2. Width of PowerPanel^{XL} panels may vary + or - 1.5mm

4.1 DELIVERY AND STORAGE

UNLOADING PANEL PACKS

Panel packs should only be unloaded and moved with approved lifting devices. Before use, the lifting devices should be checked for the required lifting tags. Packs should be unloaded as close as possible to the intended installation area. This will increase work efficiency and minimise the need for secondary lifting.

NOTE: Secondary handling increases the risk of panel damage. The repair of damage sustained during lifting and moving is the responsibility of the lifter. Where damage is excessive, PowerPanel^{XL} panels must be replaced.

STORAGE

All materials must be kept dry and preferably stored undercover. Care should be taken to avoid sagging or damage to ends, edges and surfaces.

All Hebel products must be stacked on edge and properly supported off the ground, on a level platform. Panel bundles can be stacked two high. The project engineer should be consulted as to the adequacy of the structure to support the stacked bundles.

If outside, Hebel panels must be stored off the ground and protected from the weather. Only single bundles positioned

on the ground can be opened. To provide a level surface, we recommend placing temporary joists beneath the supporting cleats.

UNSTRAPPING PACKS

Ensure appropriate bracing is installed to packs prior to removal of strapping to prevent panels from falling.

Panels can be held together with sash clamps, ratchet, straps or Hebel stabilising bars.



Figure 4.1 Stacking packs of Hebel PowerPanel^{XL}

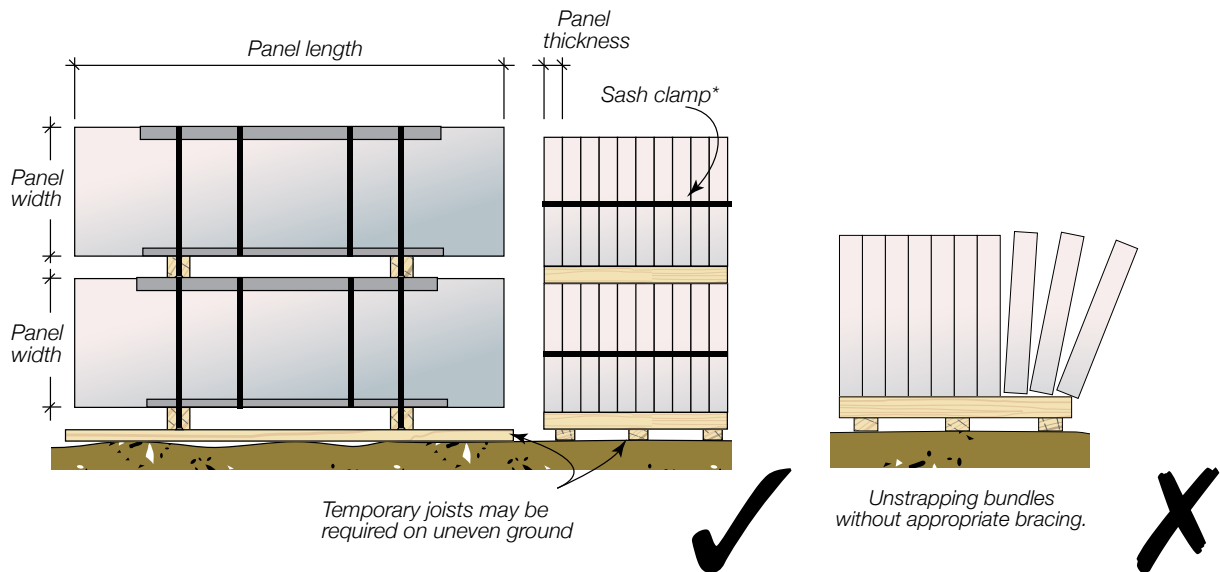

4.2 PANEL HANDLING

MANUAL HANDLING

Hebel recommends using a trolley or other mechanical apparatus to move the PowerPanel^{XL} panels around the work site. Manual handling where people physically move a panel should be kept to a minimum, with the weight being supported by an individual kept as small as possible. Any concerns regarding the weight to be handled should be discussed with the panel installation contractor.

To minimise the possibility of manual handling injuries, Hebel suggests the following:

- Use mechanical aids, such as trolleys, forklifts, cranes and levers, or team lifting to move panels
- Keep the work place clean to reduce the risk of slips, trips and falls, which can cause injury
- Plan the sequence of installation to minimise panel movements and avoid awkward lifts
- Train employees in good lifting techniques to minimise the risk of injury.

HEBEL HOIST

Building back-to-back compliant zero boundary walls on site has been largely unachievable using traditional techniques. The difficulty includes ensuring that the walls are positioned correctly without overstepping their boundaries and that the installation techniques adopted do not in any way compromise fire performance of these walls.

Due to these issues and others such as ensuring that acoustic performance (as a minimum) achieves similar performance as that required of party walls, Hebel has developed an innovative hoisting solution that now makes it easy to install Zero boundary walls and vastly improves the efficiency of installing intertenancy walls in areas with limited access.

This revolutionary patented lifting device attaches directly to the frame and features a rail and hoist which allows panels to be safely lifted, transported and placed precisely from above before being fixed from the inside of the building.

Suitable for steel or timber frames up to three storeys high, the Hebel Hoist allows builders to streamline their workflow by erecting all the frames first before installing the external panels. It also has the potential to allow builders to increase the footprint of their buildings by moving external walls right up to the boundary.

The Hebel Hoist is only available through trained and accredited Hebel installers. Please contact your local Hebel sales representative or the Hebel customer service centre to discuss the opportunity to improve your efficiency and profitability using Hebel Hoist.

Figure 4.2.1 Hebel PowerPanel^{XL} Trolley



Figure 4.2.2 Hebel Hoist



MECHANICALLY ASSISTED HANDLING

Moving and handling Hebel panels should be done as much as possible using mechanical aids such as forklifts, cranes and special panels lifting trolleys.

Guidelines for handling Hebel PowerPanel^{XL} using the PowerPanel^{XL} Trolley or PowerPanel^{XL} lifters are detailed in The Hebel Technical Manual Part 6.

HEALTH, SAFETY & PERSONAL PROTECTIVE EQUIPMENT (PPE)

Hebel products are cement-based, which may irritate the skin, resulting in itching and occasionally a red rash. The wearing of gloves and suitable clothing to reduce abrasion and irritation of the skin is recommended when handling Hebel products.

Approved respirators (AS/NZS 1715 and AS/NZS 1716) and eye protection (AS 1336) should be worn at all times when cutting and chasing. Refer to the Hebel Material Safety Data Sheets. Refer to the back of this Design & Installation Guide for further information regarding health and safety.

CUTTING

The use of power tools when cutting concrete products may cause dust, which contains respirable crystalline silica, with the potential to cause bronchitis, silicosis and lung cancer after repeated and prolonged exposure. When using power or hand tools on Hebel products, wear a P2 respirator and eye protection. When cutting, routing or chasing Hebel products with power tools, use dust extraction equipment and wear hearing protection. Refer to the appropriate Hebel MSDS. For further information, contact Hebel or visit the website: www.hebel.com.au

Reinforcement exposed during cutting must be coated with a liberal application of Hebel Anti-corrosion protection paint.

Figure 4.2.3 Personal protective equipment

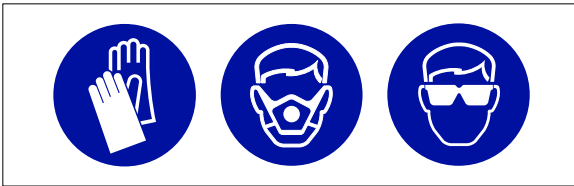

4.3 DESIGN, DETAILING AND PERFORMANCE RESPONSIBILITIES

Hebel engages independent testing laboratories to test and report on the performance of a wall in accordance with the relevant Australian Standards. Consultants use these reports as the basis for opinions (estimates of laboratory performance) they issue for variations or different arrangements to the tested system, and also to design and specify walls that meet appropriate criteria for a particular project. Using their experience, the consultant will make judgement about on-site installed performance of various walls. The performance levels of walls documented in this guide are either what is reported in a test or the documented opinion of consultants. Performance in projects is typically the responsibility of:

PROJECT CONSULTANTS (STRUCTURAL, FIRE, ACOUSTIC, ETC.)

These consultants are typically responsible for the following:

- Opinions on expected laboratory performance of wall configurations that vary from actual test configuration, such as substitution products and components
- Judgements about expected field performance using laboratory test reports and practical experience
- Design, specification and certification of structural, fire, acoustic, durability, weather tightness and any other required performance criteria for individual projects

This involves the design and selection of building elements, such as wall and floors and their integration into the building considering the following:

- Interface of different building elements and to the structure / substrate
- Wall and floor junctions
- Penetrations
- Flashing issues
- Room / building geometry
- Acoustic and water penetration field-testing.

PROJECT CERTIFIER AND/OR BUILDER

These professionals are typically responsible for:

- Identifying the performance requirements for the project in accordance with the National Construction Code and clearly communicating this to the relevant parties.
- Applicability of any performance characteristics supplied by Hebel including test and opinions for the project.
- The project consultant's responsibilities detailed above if one is not engaged in the project.

Hebel does not provide consulting services. Hebel only provides information that has been prepared by others and therefore shall not be considered experts in the field.

Any party using the information contained in this guide or supplied by Hebel in the course of a project must satisfy themselves that it is true, current and appropriate for the application, consequently accepting responsibility for its use.

It is the responsibility of the architectural designer and engineering parties to ensure that the details in this design guide are appropriate for the intended application.

The recommendations in this guide are formulated along the lines of good building practice, but are not intended to be an exhaustive statement of all relevant data.

Hebel is not responsible for the performance of constructed walls, including field performance, and does not interpret or make judgements about performance requirements in the NCC.

APPENDIX A: HEBEL POWERPANEL^{XL} MATERIAL PROPERTIES

A.1 Manufacturing tolerances

Length	±5mm
Width	±1.5mm
Thickness	±1.5mm
Diagonals (max.)	5mm
Edge Straightness Deviation (max.)	1.5mm

A.2 PowerPanel^{XL} physical properties

- Hebel PowerPanel^{XL} profile and nominal dimensions are shown in Section 1.4.
- Panel reinforcement is a single layer of steel mesh with 4 longitudinal wires of 4mm diameter.
- Nominal dry density = 400 kg/m³.
- Average working density = 540 kg/m³ at 35% moisture content.
- Average service life density = 440 kg/m³ at 10% moisture content.
- Hebel PowerPanel^{XL} is manufactured in a range of stock sizes as detailed below:

Panel weight (kg)		
Length (mm)	Width (mm)	Weight (kg) at 35% M.C.
2400	600	58
2550	600	62
2700	600	66
2800	600	68
2850	600	69
3000	600	73
3300	600	80

NOTE: 75mm PowerPanel 1200 x 600mm weight 37kg.
75mm PowerPanel 1800 x 600mm weight 56kg.

A.3 PowerPanel^{XL} strength properties

- Characteristic Compressive Strength or AAC, $f'_{m} = 2.38$ MPa.
- Average Compressive Strength of AAC = 2.8 MPa.
- Characteristic Modulus of Rupture, $f'_{ut} = 0.40$ MPa.

A.4 PowerPanel^{XL} acoustic properties

- Panel only with no plasterboard or other lining
 $R_w = 34$ dB, $R_w + C_{tr} = 30$ dB (refer to Acoustic Logic Test Report ref: 2010861.15/2602A/R2 GW).

A.5 PowerPanel^{XL} thermal properties

- R-Value of PowerPanel^{XL} with no plasterboard or other lining = 0.520 m².K/W (4% moisture content).

A.6 Fire hazard indices

Hebel products have BCA Group Number 1 and also the following early fire hazard indices, determined in accordance with AS1530.3:1990:

Ignitability Index	0
Spread of Flame Index	0
Heat Development Index	0
Smoke Development Index	0-1

A.7 Fire Resistance Level (FRL) Ratings

For fire performance characteristics of Hebel PowerPanel^{XL}, refer to Section 2.2 of this guide.

A.8 Typical Hebel PowerPanel^{XL} cross section

Typical Hebel Powerpanel^{XL} cross section for 2400 - 3000mm panel length:

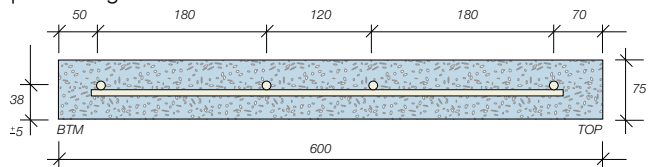

Typical Hebel Powerpanel^{XL} cross section for 3300mm panel length:

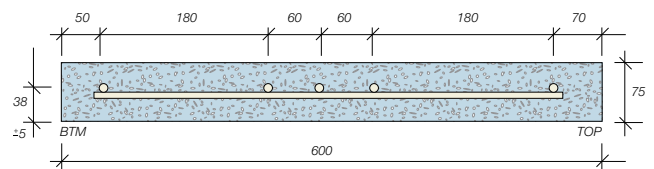

NOTES:

1. BTM: To locate the approximate location of reinforcing the smooth edge of the panel is the bottom (BTM).
2. Bars: 4x4mm \varnothing longitudinal & 6-8 transverse bars depending on panel length.
3. Tolerance: The width & thickness of PowerPanel^{XL} panels are manufactured to a tolerance of +1 or -1.5mm.
4. Cutting: Panels typically to be no less than 270mm wide. Where narrower panels are used, these panels must not be less than 100mm in width and must be installed between full width panels. Reinforced fibreglass mesh to be embedded in base levelling coat across the full width of the narrower panel.
In cases where the installation is such that a panel as narrow as 100mm in width is to be installed on its own i.e such as between two adjacent window or door openings, then this installation method is deemed acceptable provided that this narrow panel can be cut, handled and installed without the panel cracking or becoming damaged (damaged or cracked panels must be discarded). In these cases, reinforced fibreglass mesh is to also be embedded in base levelling coat across the full width of this narrow panel.

APPENDIX B: POWERPANEL^{XL} EXTERNAL WALL SYSTEM DESCRIPTIONS

C.1: Hebel PowerPanel^{XL} External Wall System - timber stud frame

Hebel code	Description					
	Platerboard	Stud frame	Batts	Wall wrap	Top hat cavity	Hebel Panel
Hebel1716	10mm Gyprock Plasterboard Plus	70mm timber Stud frame	None	Polyair Performa 4.0 XHD	24mm	75mm thick Hebel PowerPanel ^{XL}
Hebel1717			70mm Bradford Soundscreen Batts R2.0	Thermoseal Wall Wrap XP		
Hebel1718			70mm Bradford Soundscreen Batts R2.0	Enviroseal ProctorWrap RW		
Hebel1721			None	Polyair Performa 4.0 XHD	35mm	
Hebel1722			70mm Bradford Soundscreen Batts R2.0	Thermoseal Wall Wrap XP		
Hebel1723			70mm Bradford Soundscreen Batts R2.0	Enviroseal ProctorWrap RW		
Hebel1726		90mm timber Stud frame	None	Polyair Performa 4.0 XHD	24mm	
Hebel1727			90mm Bradford Gold Wall Batts R2.0	Thermoseal Wall Wrap XP		
Hebel1728			90mm Bradford Gold Wall Batts R2.5	Enviroseal ProctorWrap RW		
Hebel1730			90mm Bradford Gold Wall Batts R2.7	Enviroseal ProctorWrap RW		
Hebel1733			None	Polyair Performa 4.0 XHD	35mm	
Hebel1734			90mm Bradford Gold Wall Batts R2.0	Thermoseal Wall Wrap XP		
Hebel1735			90mm Bradford Gold Wall Batts R2.5	Enviroseal ProctorWrap RW		
Hebel1737			90mm Bradford Gold Wall Batts R2.7	Enviroseal ProctorWrap RW		

C.2: Hebel PowerPanel^{XL} External Wall System - steel stud frame

Hebel code	Description					
	Platerboard	Stud frame	Batts	Wall wrap	Top hat cavity	Hebel Panel
Hebel1706	10mm Gyprock Plasterboard Plus	64mm steel Stud frame	None	Polyair Performa 4.0 XHD	24mm	75mm thick Hebel PowerPanel ^{XL}
Hebel1707			70mm Bradford Soundscreen Batts R2.0	Thermoseal Wall Wrap XP		
Hebel1708			70mm Bradford Soundscreen Batts R2.0	Enviroseal ProctorWrap RW		
Hebel1711			None	Polyair Performa 4.0 XHD	35mm	
Hebel1712			70mm Bradford Soundscreen Batts R2.0	Thermoseal Wall Wrap XP		
Hebel1713			70mm Bradford Soundscreen Batts R2.0	Enviroseal ProctorWrap RW		
Hebel1740		92mm steel Stud frame	None	Polyair Performa 4.0 XHD	24mm	
Hebel1741			90mm Bradford Gold Wall Batts R2.0	Thermoseal Wall Wrap XP		
Hebel1742			90mm Bradford Gold Wall Batts R2.5	Enviroseal ProctorWrap RW		
Hebel1744			90mm Bradford Gold Wall Batts R2.7	Enviroseal ProctorWrap RW		
Hebel1747			None	Polyair Performa 4.0 XHD	35mm	
Hebel1748			90mm Bradford Gold Wall Batts R2.0	Thermoseal Wall Wrap XP		
Hebel1749			90mm Bradford Gold Wall Batts R2.5	Enviroseal ProctorWrap RW		
Hebel1751			90mm Bradford Gold Wall Batts R2.7	Enviroseal ProctorWrap RW		



CSR HEBEL

Trinity 3, 39 Delhi Road
North Ryde NSW 2113, Australia
Telephone +61 2 9235 8000

Health & safety

Information on any known health risks of our products and how to handle them safely is on product packaging and / or the accompanying documentation.

Additional information is listed in the Material Safety Data Sheet (MSDS). To obtain a copy of a MSDS, download from www.hebel.com.au. Contractors are required by law to perform their own risk assessments before undertaking work.

Performance & certification

Hebel® products and systems are developed in Australia by CSR Building Products. ABN. 55 008 631 356. It is a manufacturer and supplier of Hebel Autoclaved Aerated Concrete (AAC) products. Because it is a manufacturer and supplier only, CSR does not employ people qualified as Accredited or Principal Certifiers.

CSR is therefore unable to provide Construction Compliance Certificates or Statements of Compliance. CSR conducts appropriate testing of its products and systems to determine performance levels. These include structural, fire and acoustic tests. Testing is conducted and certified by appropriate specialists in these fields. When using Hebel products and systems in specific projects, such specialists should be consulted to ensure compliance with the Building Code of Australia and relevant Australian Standards.

Disclaimer

Information presented in this document is supplied in good faith and to the best of our knowledge was accurate at the time of preparation. The provision of this information should not be construed as a recommendation to use any of our products in violation of any patent rights or in breach of any statute or regulation. Users are advised to make their own determination as to the suitability of this information in relation to their particular purpose or specific circumstances. Since the information contained in this document may be applied under conditions beyond our control, no responsibility can be accepted by CSR, or its staff for any loss or damage caused by any person acting or refraining from action as a result of misuse of this information.

Other

The design of a wall, floor or fence system requires the services of professional consultants. This document has been prepared as a source of information to provide general guidance to those consultants – and in no way replaces the services of the professional consultant and relevant engineers designing the project.

No liability can therefore be accepted by CSR or other parties for the use of this document. Hebel products and systems undergo constant research and development to integrate new technology and reflect ongoing performance enhancement.

Hebel systems are constantly reviewed so as to reflect any changes in legislative building requirements and or general developments in common building practice, due to our commitment to continual development and improving our building systems.

We advise that all users of this document should regularly check that this document is current, and they are applying our latest design information.

The latest editions of our documents are available on our website:
www.hebel.com.au

Hebel® is a registered trademark of the Xella group. CSR Building Products Ltd is an exclusive licensee of Xella. CSR Hebel is a business of CSR Building Products Ltd ABN 55 008 631 356.

CSR, PowerPanel®, PowerClad®, Hebel Block®, PowerFloor®, Hebel Floor®, PowerFence®, HighBuild®, are registered trademarks of CSR Building Products Limited.

THE BETTER WAY TO BUILD

Hebel is a quality building product, and is backed by CSR Building Products Limited.

For more information visit our website:

www.hebel.com.au

For sales enquiries or further information, please telephone us from anywhere in Australia:

1300 369 448

