

Houses and  
Low Rise  
Multi Residential  
PowerProfile  
External Walls  
INSTALLATION GUIDE



# THIS INSTALLATION GUIDE MUST BE USED IN CONJUNCTION WITH THE HOUSES AND LOW RISE MULTI RESIDENTIAL POWERPANEL<sup>XL</sup> EXTERNAL WALLS DESIGN & INSTALLATION GUIDE HELIT016

This Design and Installation Guide has been prepared as a source of information to provide general guidance to consultants – and in no way replaces the services of the professional consultant and relevant engineers designing the project.

It is the responsibility of the architectural designer and engineering parties to ensure that the details in this Design and Installation Guide are appropriate for the intended application.

The recommendations of this guide are formulated along the lines of good building practice, but are not intended to be an exhaustive statement of all relevant data.

## CONTENTS

<b>Introduction</b>	<b>1</b>
<b>1. Design and selection details</b>	<b>2</b>
1.1 Tools and equipment	2
1.2 Consumables	3
1.3 Profile elements	4
<b>2. Installation details</b>	<b>6</b>
2.1 Installation overview	7
2.2 Control Joints	10
2.3 Coating	12
2.4 Fixing backing clips and profiles	13
<b>3. Handling, storage and responsibility</b>	<b>20</b>
3.1 Delivery and storage	20
3.2 Panel handling	21
3.3 Design, detailing and performance responsibilities	22
<b>Appendices</b>	<b>23</b>
Appendix A: Dulux Acratex coating system for CSR Hebel PowerProfile	23
Appendix B: Rockote coating system for CSR Hebel PowerProfile	28

# POWERPROFILE®

Hebel's PowerProfile is a simple way to accessorise your Hebel facade to replicate the look of traditional standing seam.

The PowerProfile system consists of Hebel's PowerPanelXL 75mm thick, steel-reinforced AAC panels vertically secured to the structural frame via horizontal perforated top hat sections. When the facade is coated, decorative profiles are fixed to the substrate to achieve the desired look.

The powder coated, aluminium profiles are available in two forms and three popular Colorbond® colours: Basalt®, Dune® and Monument®.

## FEATURES AND BENEFITS:

- An affordable option compared to that of standing seam and similar metal cladding systems.
- Strong 75mm thick, steel reinforced panels provide a solid wall with deep window reveals.
- Helps overcome the issues associated with morning and afternoon glancing light.

- Choice of aluminium profiles and colours.
- Maintains strong Hebel thermal and outstanding fire performance.
- Suitable for timber and steel construction.

**Fire rating:** Up to 180/180/180 when subjected to an external fire source\*.

**Acoustic:** Rw + Ctr 38 to 42 based on a 210mm wall system thickness.

**Thermal:** R2.13 to R3.29.

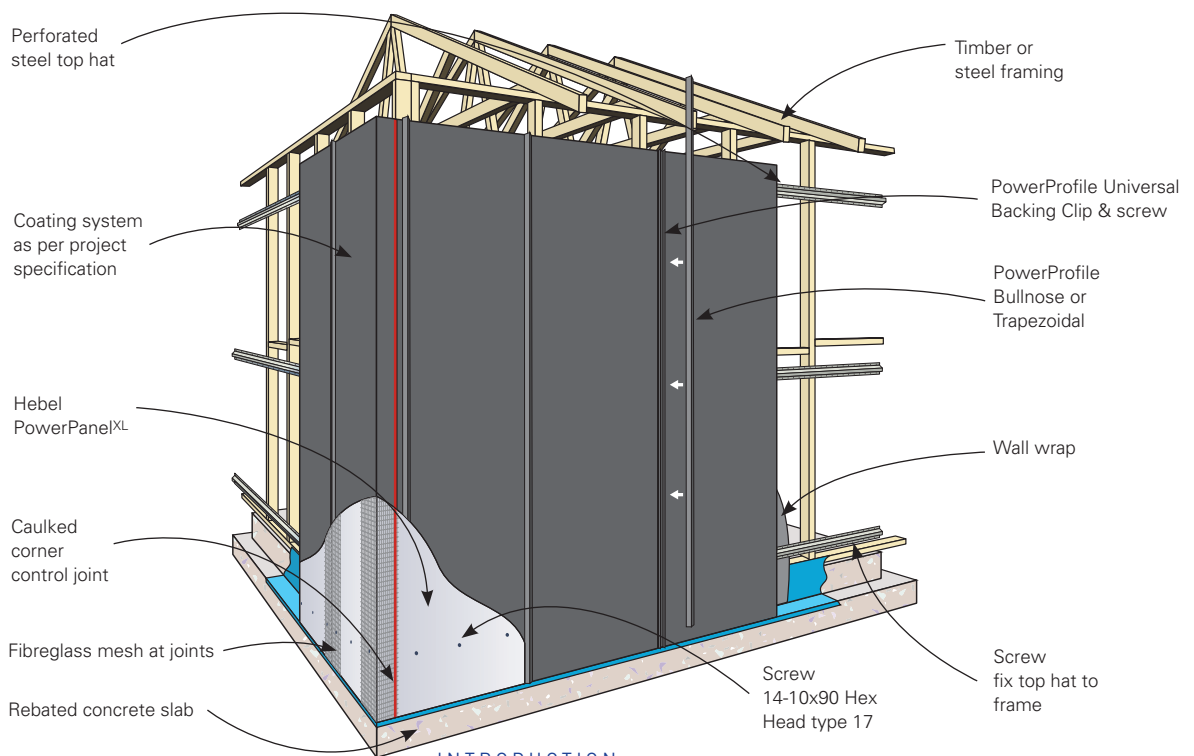
**Common Wall Thickness:** 199mm, based on 90mm stud + 10mm plasterboard + 24mm top hat + 75mm PowerProfile. With variations in stud thickness and top hats, wall widths can vary between 179mm to 210mm (excluding profile depth).

**Coating system:** Panels should be coated with a suitable and compatible acrylic coating system.

\* Based on a system using Hebel Adhesive at panel joints.

## HEBEL POWERPROFILE EXTERNAL WALL SYSTEM

The PowerProfile system consists of 75mm thick, steel reinforced Hebel PowerPanelXL and aluminium profile elements fixed to the substrate.



# 1.1 TOOLS AND EQUIPMENT

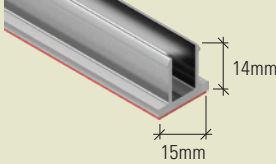
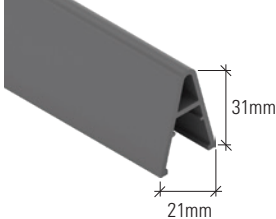
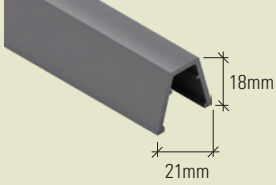
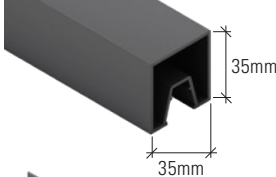
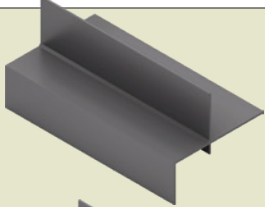
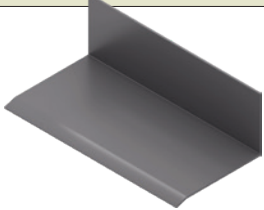


(IN ADDITION TO POWERPANEL<sup>XL</sup> CLADDING TOOLS)

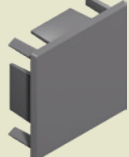

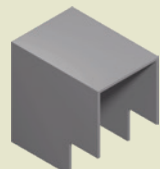



Product	Description	Use
	<p>Straight edge/ Level 2.1m and 1.2m</p>	<p>Checking alignment of panel joint and to align and level backing clips during installation.</p>
	<p>Drop Saw fitted with suitable Aluminium cutting disc</p>	<p>Trimming backing clips and profiles to length. Note: A normal Mitre Drop Saw fitted with cutting disc suitable for Aluminium should be used.</p>
	<p>Rubber Mallet</p>	<p>Installing Profiles securely onto backing clips.</p>
	<p>Solid (non scratch) Load Spreader</p>	<p>Ensures that wider profiles are not damaged when hit with a rubber mallet. Recommended for use with Perimeter Trim.</p>
	<p>5mm and 10mm Packers</p>	<p>Ensures accurate spacing/gaps are positioned where required.</p>
	<p>Small Square</p>	<p>Checks Universal Backing Clips around openings are square to ensure cover caps fitment.</p>

## 1.2 CONSUMABLES

Product		Supplied by	Description
	Isopropyl Alcohol	Selected Hardware Suppliers	Required when there is an excessive build-up of dirt, dust, grease or moisture that needs to be removed from Hebel wall prior to installing Universal Backing Clips.
	Aluminium Profile and Accessories Touch Up Paint	Selected Dulux Trade stores	Refer to Dulux Specification Appendix A
	Dulux AcraPatch 50/50 mix		
	Dulux Render Wall 50/50 mix		
	Dulux AcraShield Membrane Paint		
	Rockote Quick Render Fibre Reinforced	Selected Rockote Trade stores	Refer to Rockote Specification Appendix B
	Rockote Masonry Primer Hi Op		
	Rockote Armour Flex		
	Fine Texture Roller	Selected Hardware Suppliers	

# 1.3 PROFILE ELEMENTS

Codes			System components	Application	
Raw milled finish	<b>1.2m</b>	<b>3m</b>	Universal Base Clip (1.2m Pack size 12) (3.0m Pack size 1)	Fixed over Hebel substrate for profiles and trims	
	454789	466627			
	<b>3m</b>	<b>4.8m</b>	Bullnose Profile (Pack size 5)	Fixes to Universal Base Clip to create decorative facade feature	
Basalt	454994	454986			
Dune	454993	454985			
Monument	454995	454987			
Basalt	454978	454970	Trapezoidal Profile (Pack size 5)	Fixes to Universal Base Clip to create decorative facade feature	
Dune	454977	454969			
Monument	454979	454971			
Basalt	454962	454954	Perimeter Trim (Pack size 2)	Fixes to Universal Base Clip around windows and openings to create a decorative feature	
Dune	454961	454953			
Monument	454963	454955			
Basalt	455006	455002	Parapet Perimeter Trim (Pack size 2)	Provides a top perimeter trim to parapet walls	
Dune	455005	455001			
Monument	455007	455003			
Basalt	455018	455014	Cantilevered Panel Base Angle (Pack size 5)	Provides a finish to underside of suspended Hebel panel	
Dune	455017	455013			
Monument	455019	455015			
Basalt	455022		Bullnose Profile End Cap (Pack size 2)	Fits over end of Bullnose Profile	
Dune	455021				
Monument	455023				
Basalt	455054		Trapezoidal Profile End Cap (Pack size 2)	Fits over end of Trapezoidal Profile	
Dune	455053				
Monument	455055				

Codes		System components	Application	
Basalt	455046	Perimeter Trim End Cap (Pack size 2)	Fits over end of Perimeter Trim	
Dune	455045			
Monument	455047			
Basalt	455026	Perimeter Trim Corner Joiner - Vertical (Pack size 2)	Joins Perimeter Trims at vertical corners	
Dune	455025			
Monument	455027			
Basalt	455030	Perimeter Trim Corner Joiner - Horizontal (Pack size 1)	Joins Perimeter Trims at horizontal corners	
Dune	455029			
Monument	455031			
Basalt	455050	Perimeter Trim Straight Joiner (Pack size 1)	Joins Perimeter Trims as required	
Dune	455049			
Monument	455051			
Basalt	455034	Parapet Trim External Corner Joiner (Pack size 1)	Joins Parapet Perimeter Trims at external corners	
Dune	455033			
Monument	455035			
Basalt	455038	Parapet Trim Internal Corner Joiner (Pack size 1)	Joins Parapet Perimeter Trims at internal corners	
Dune	455037			
Monument	455039			
Basalt	455042	Parapet Trim Straight Joiner (Pack size 1)	Joins Parapet Trims as required	
Dune	455041			
Monument	455043			
466628		6G 1-3/4" (44mm) Stainless Steel Screw (Box 200)	Fixing Universal Base Clip to Hebel substrate	

These profile elements are available in a powder coated finish in popular Colorbond® colours: Basalt®, Dune® and Monument®.



## REFER TO THE HOUSES AND LOW RISE MULTI RESIDENTIAL POWERPANEL<sup>XL</sup> EXTERNAL WALLS DESIGN & INSTALLATION GUIDE HELIT016 FOR DETAILS REGARDING:

The PowerProfile system consists of 75mm thick, steel reinforced Hebel PowerPanel<sup>XL</sup> and aluminium profile elements fixed to the substrate.

### **Design and selection details**

- Designing an external wall using Hebel PowerPanel<sup>XL</sup>
- Structural provisions
- Design & detailing considerations
- System components

### **System performance**

- Durability
- Fire resistance performance
- Energy efficiency
- Sound transmission and insulation
- Weatherproofing

### **Installation details**

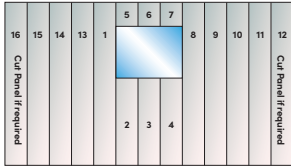
- Hebel PowerPanel<sup>XL</sup> installation sequence
- Tools and equipment for construction
- Installation of services
- External Aluminium render bead
- Construction details





THE FOLLOWING INSTALLATION OVERVIEW IS TO BE FOLLOWED IN ACCORDANCE WITH THE HEBEL DESIGN AND INSTALLATION GUIDE- HELIT016-HOUSES AND LOW RISE MULTI RES POWERPANEL<sup>XL</sup> EXTERNAL WALLS

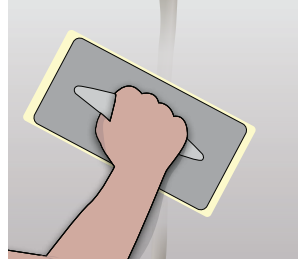
## 2.1 INSTALLATION OVERVIEW



### Step 1

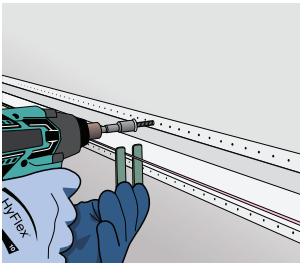
Hebel panels are to be installed with the utmost consideration of aesthetic locations of the profiles, and especially in relation to the position of control joints.

Carefully consider the desired design outcome when installing panels. Refer to detail on page 9.



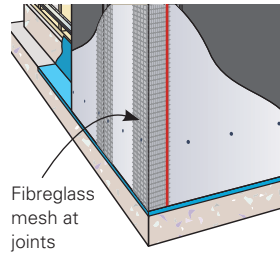
### Step 7

Use sand float to remove excess Hebel Adhesive and smooth the joints between each of the panels.



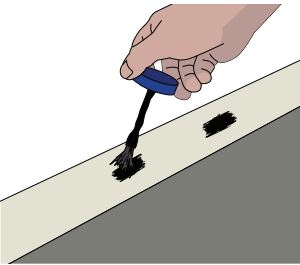
### Step 2

Fix Hebel perforated top hats to timber or steel frame ensuring they are plumb, level. Creating a straight and true substrate.



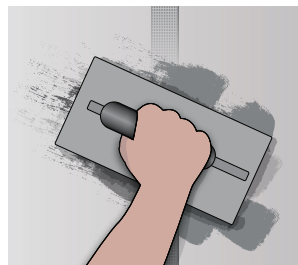
### Step 8

Install 200mm of 165gsm wide mesh to each Hebel panel joint.



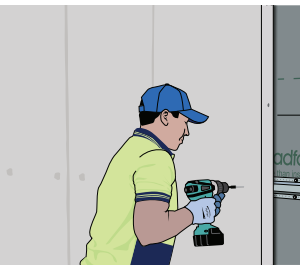
### Step 3

Coat any exposed steel reinforcing from cutting with Hebel anti-corrosion paint.



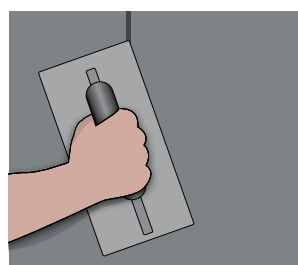
### Step 9

Install Base Levelling Skim Coat. Coatings are designed for the mesh to be slightly visible.



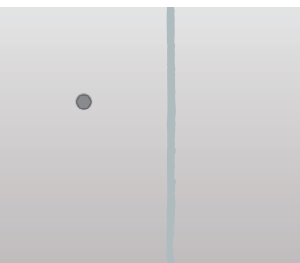
### Step 4

Install PowerPanel<sup>XL</sup> panels vertically by applying Hebel Adhesive to each panel joint and screwing off to perforated Top Hats.



### Step 10

Coatings are to go over the control joint. Using a blade (hand scribe or trowel) cut a nice straight line over the sealant joint through to the base coat, the width of the control joint (nominal 10mm) and to a depth to meet the sealant.



### Step 5

Install control joints in accordance with Hebel Install Guides. The location of joints must be considered with respect to location of profile.

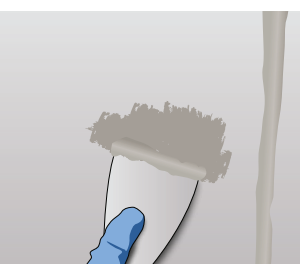
Maintain 10mm to joints.



### Step 11

Apply the recommended coating system. Allow to fully dry prior to adhering any backing clips.

Note: Dulux Sienna Naturale will give a very smooth finish and the closest resemblance to a metal cladding finish however, it is a coating upgrade.



### Step 6

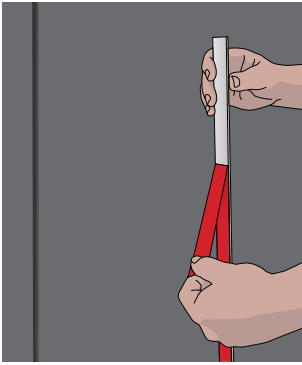
Patch minor panel imperfections and screw holes using Dulux AcraPatch.

Selleys Spakfilla Rapid should be used to achieve a flush finish when using the Sienna Naturale coating system.



### Step 12

Before applying backing clip, clean the surface with a lint free cloth and Isopropyl Alcohol.



### Step 13

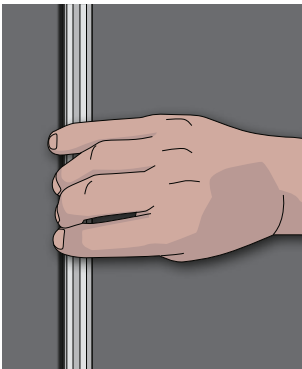
Peel approximately 150mm length of paper from backing clip tape, preferably at the base.



### Step 16

Snap profile to backing clip using a rubber mallet.

A load spreader can also be used to further protect the Aluminium.

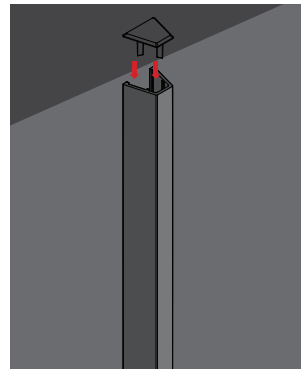


### Step 14

It is critical to install the backing clip straight so ensure you use a levelling tool. Fix backing clip to the wall keeping it straight to the levelling tool whilst peeling the tape in an upwards motion.

The tape will adhere IMMEDIATELY.

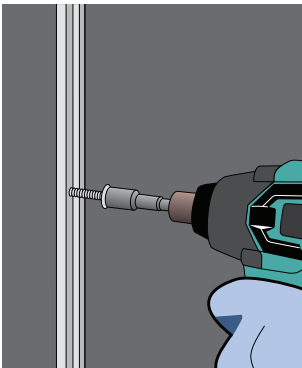
The backing clips can be applied in sections or continuously across the facade.



### Step 17

Finish with inserting end caps to each profile at visible ends.

Perimeter profiles can be used around windows and openings.



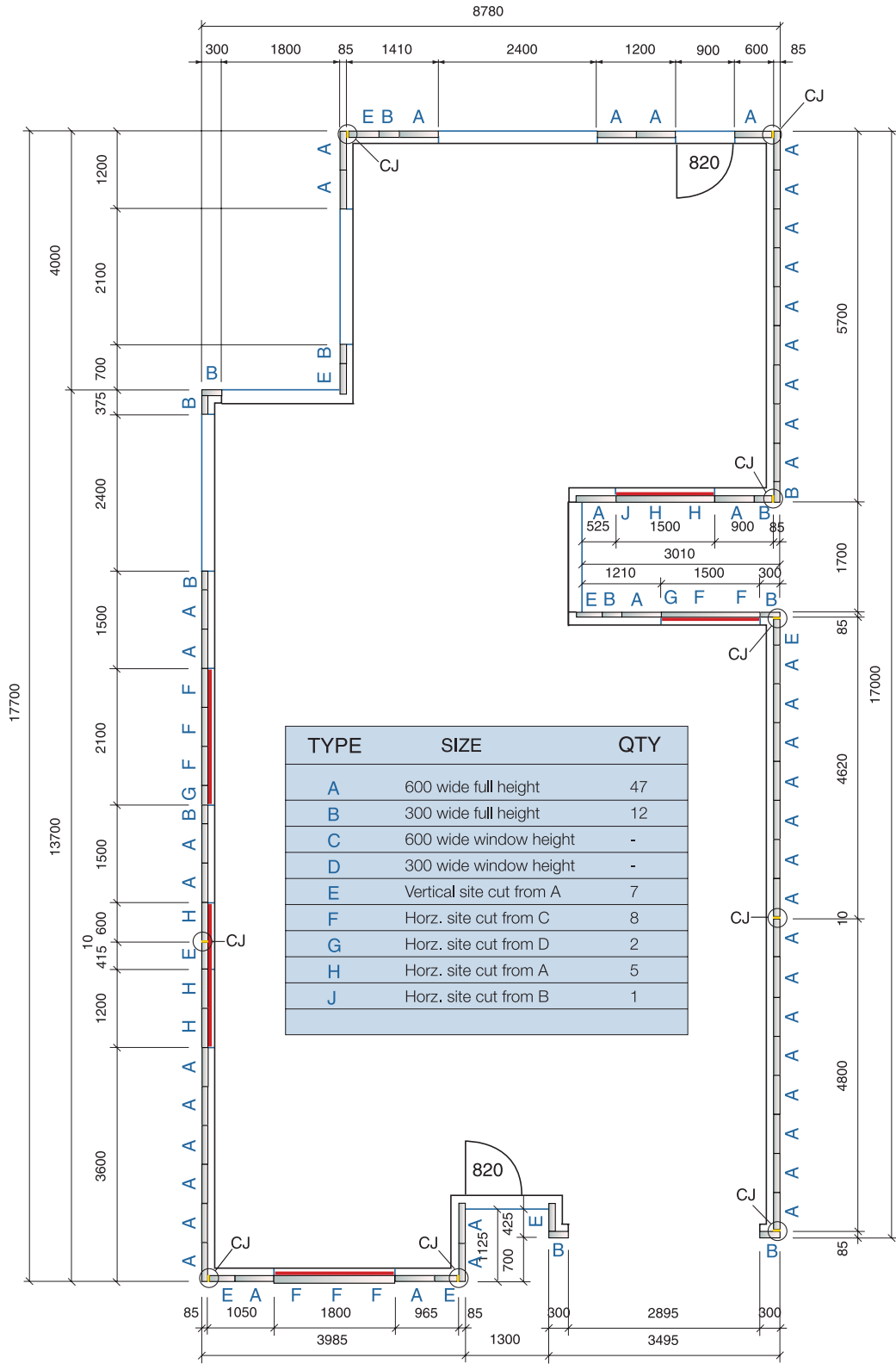
### Step 15

Screw the Universal Backing Clip to the wall at least 100mm from the end of the clip, and then at 300mm centres.

At control joints it is recommended that screws through the base clip are a minimum of 20mm from the end of the panel.

Note: Pre Drilling a 2.5mm Hole may be required.

PANEL LAYOUT - HEBEL PANELS ARE TO BE INSTALLED WITH THE UTMOST CONSIDERATION OF AESTHETIC LOCATIONS OF THE PROFILES, AND ESPECIALLY IN RELATION TO THE POSITION OF CONTROL JOINTS. CAREFULLY CONSIDER THE DESIRED DESIGN OUTCOME WHEN INSTALLING PANELS.



# 2.2 CONTROL JOINTS

## ENSURE ALL PANEL JOINTS ARE MESHD

### 2.2.1 VERTICAL CONTROL JOINTS

- Vertical Control Joints should be located at corners (Fig 1.1) and considering the use of mesh at maximum centres as detailed in table 1.3.1 of the Hebel PowerPanelXL External walls design & installation guide.
- The layout of control joints, in particular vertical control joints, should be carefully considered. Doing this at design stage is the optimum time as it allows for size and positioning of opening to be considered with positioning and spacing of profiles.
- All vertical control joints should have the base skim coat applied over the control joint (Nominal 10mm width) and blade or disc cut through to the base coat to a width no greater than 10mm and to a depth to meet the sealant (prior to paint application).

Figure 1.1 Corner Control Joint

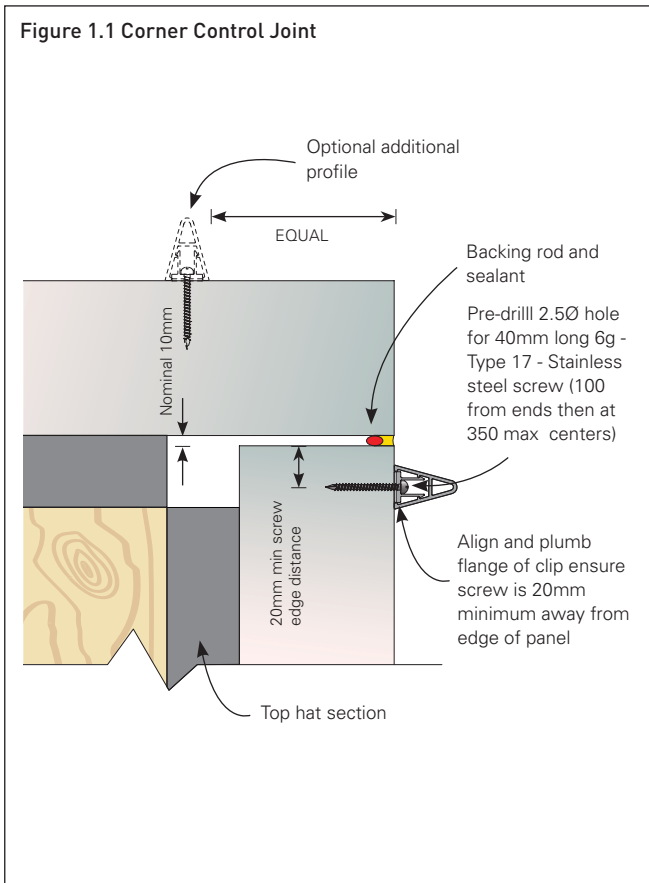
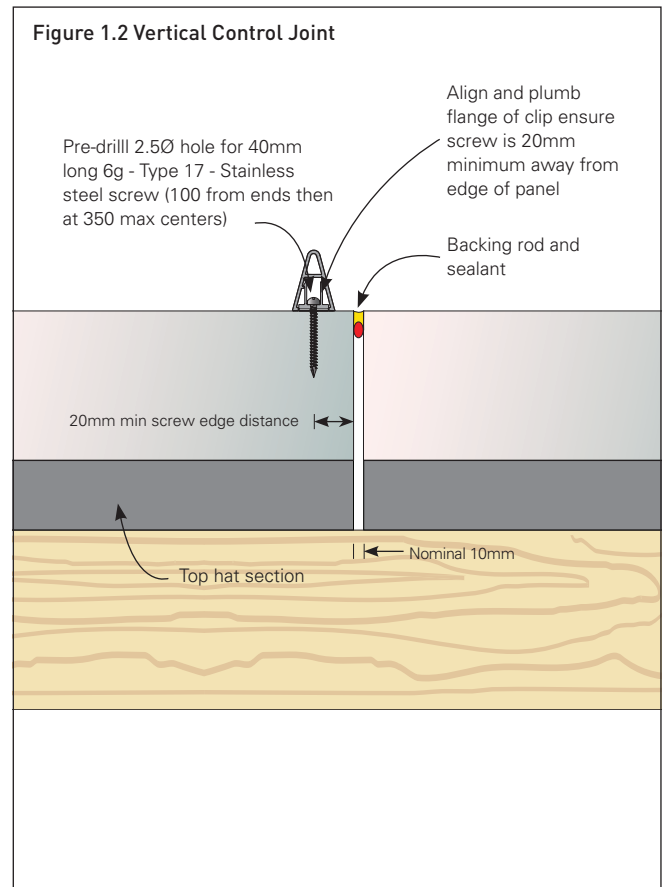


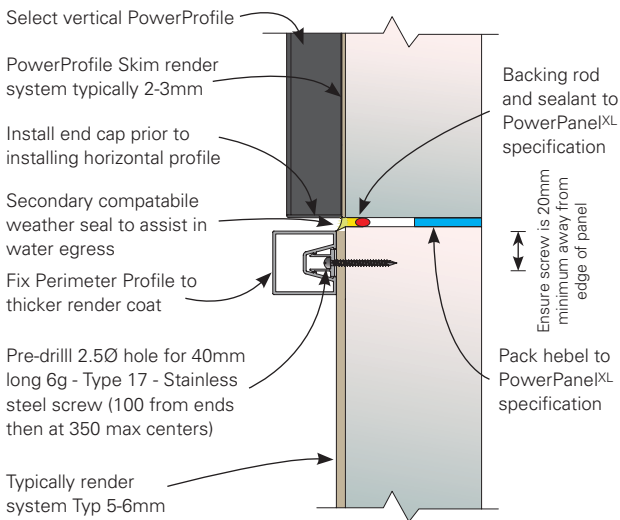
Figure 1.2 Vertical Control Joint



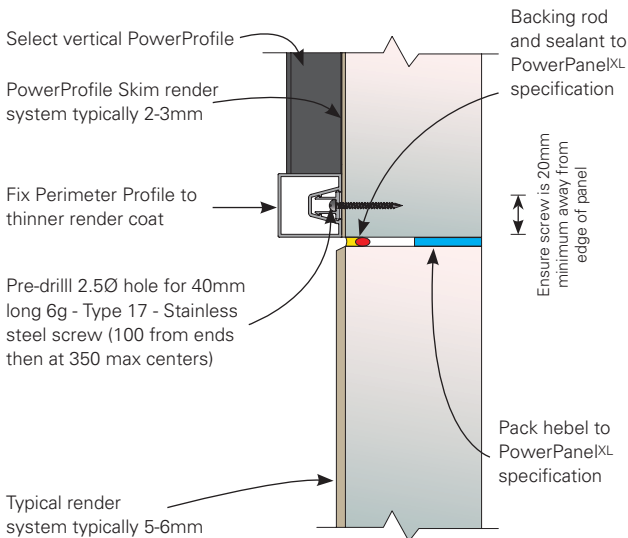
## 2.2.2 HORIZONTAL CONTROL JOINTS

■ As the horizontal control joint typically separates an upper floor from a lower. In most cases the PowerProfile will only be adopted for the upper level, hence it is important that the Universal Base Clip is adhered to the wall which has the thickest coating system build. Typically this will be the top of the lower wall. This will ensure that the profile will snap into the Universal Base Clip and will not be hindered by the thicker build in coating on the lower wall (1.3.1 & 1.3.2).

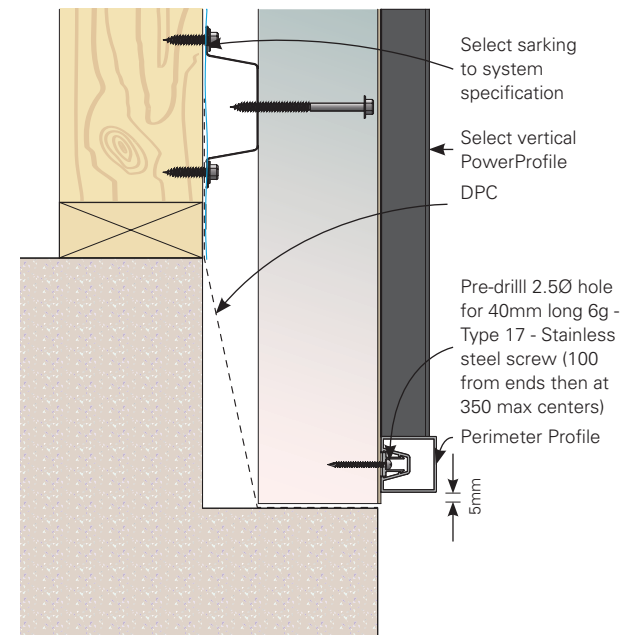
**Figure 1.3.1 Section View Horizontal Control Joint Detail**



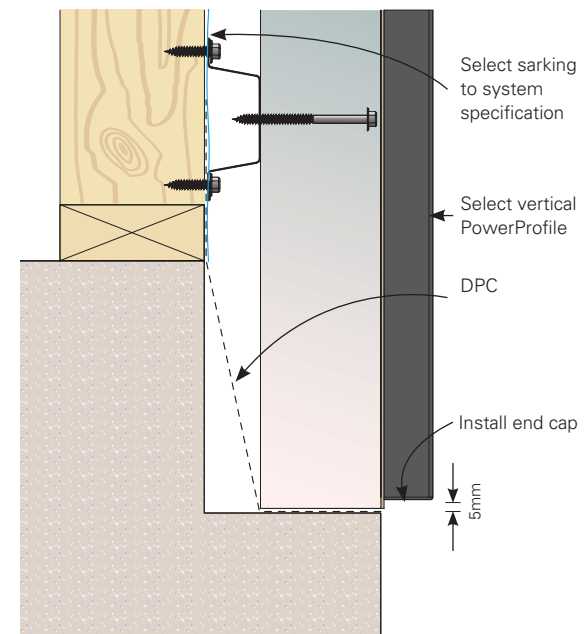
**Figure 1.3.2 Section View Horizontal Control Joint Detail**



**Figure 1.4.1 Perimeter profile at Slab Detail**



**Figure 1.4.2 Without Perimeter profile at Slab Detail**



## 2.3 COATING

### 2.3.1 PREPARATION OF HEBEL SUBSTRATE

To ensure a single skim coat application provides sufficient cover **panels should be checked for alignment and any mis-alignment (with particular attention to panel joints) should be sanded flush prior to base skim coat application.**

Any panel damage, panel joints and screw holes should be patched and sanded flush ready for application of base coat. This is critical as the coating application needs to be relatively thin and smooth to achieve the best result for fixing Universal Backing Clips and profiles to the coated Hebel wall.

### 2.3.2 APPLICATION OF COATING SYSTEM

- The following considerations will ensure a suitable coating system for PowerProfile is adopted. It is important that the coating manufacture has tested and approved their system for this application.
- The Universal Backing Clip is designed to fix to a relatively smooth flat surface. Undulations in the coating system will inhibit the Universal Base Clips achieving good continuous contact with the finished coated wall. It is therefore important that a single low build skim coat system be adopted. This allows the applicator greater ease in achieving a flatter surface with minimal deviations.
- Only coating systems approved and tested by the coating manufacturer to both meet the above criteria and that achieve the VHB tape bond strength and screw fixing requirements should be adopted.
- Coating system as detailed in Appendix A or Appendix B "Coating requirements for PowerProfile" should be followed as a tested and approved system.

The coating system would typically include:

- Application of a 200mm wide 165gsm alkali resistant mesh stapled with stainless steel staples to all panel joints to alleviate cracking.
- Acrylic skim base coat at a minimum 1.5mm thickness applied to cover panel joints, floated to an even and level finish to enable good surface contact with VHB Tape. (A tested system to achieve good contact and adhesion of backing clips must be adopted.)
- 2 coats Acrylic Elastomeric Membrane topcoat applied by Superfine Black texture roller to the skim coat and finished to a semi-smooth surface profile suitable for application and adhesion of VHB tape.

### 2.3.3 STANDARD COLOURS

- All Profiles, Trims and End Caps are available in a matt powder coated finish in 3 standard Colorbond® colours: Basalt®, Dune® and Monument®.

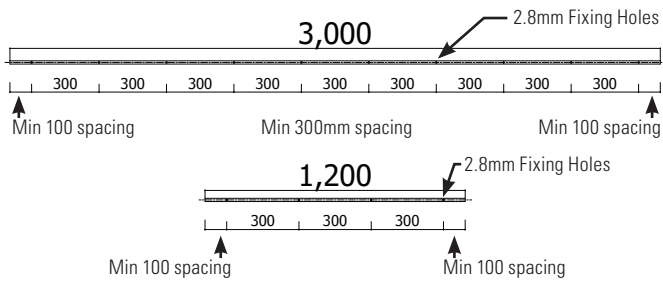
Should non-standard colours be required, contact your Hebel representative for further information.

# 2.4 FIXING BACKING CLIPS AND PROFILES

## 2.4.1 PREPARATION

The Universal Backing Clips are delivered with 3M VHB double sided tape to the back face.

The Universal Backing Clips need to be pre-drilled with a 2.8mm drill bit at recommended spacings:

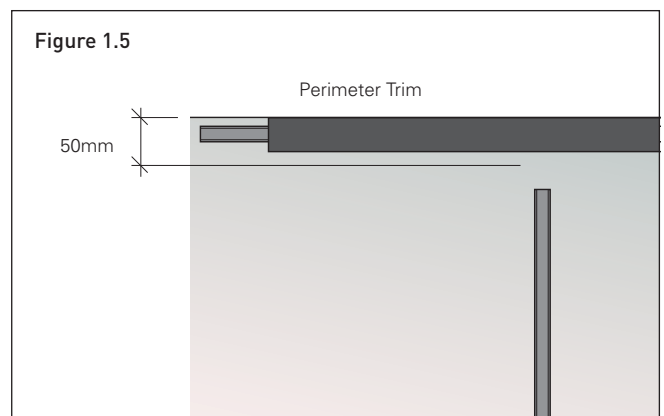


The Universal Backing Clip is adhered to the wall by removing the protective film from the outside face of the double-sided 3M VHB adhesive tape in conjunction with screw fixings at no less than 300mm intervals.

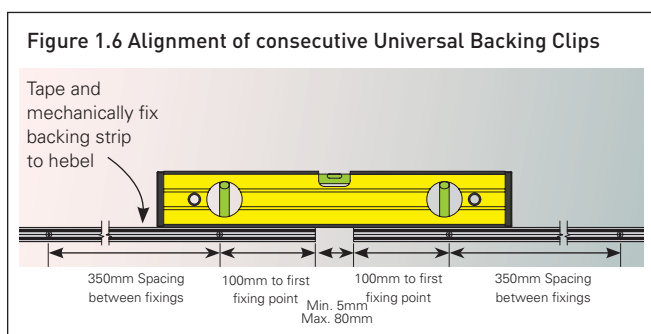
- Before commencing installation of the backing clip ensure the wall is free of grease and dirt and **TOTALLY DRY** of moisture. Most substrates are best prepared by cleaning with a mixture of isopropyl alcohol (IPA) and water (approximately 50-70% IPA) prior to applying the Profiles. In cooler climates and where possible, backing clips should be kept in a warm location to assist with maximum adhesion.
- The backing clips will gain an initial bond of approximately 50% of their full strength on application once pressure is applied to the clip.
- Full bond strength of the adhesive tape is achieved in 72 hours after fixing. This will not prevent you from installing profiles immediately after backing clips have been installed.
- Clips should be installed using a 1.2m long level to ensure that they are plumb, straight and aligned with adjoining backing clips. A 2.4m level should be used for the 3m base clip.
- As a general rule backing clips and profiles around openings and perimeter of wall and vertical control joints should be installed first. The Parapet profile should be installed last.

## 2.4.2 INSTALLATION OF VERTICAL BACKING CLIPS

- Determine location for backing clip by checking the length of the wall with your level where the backing clip is to be installed. Typically this will be on a panel joint. (The panel joint line is plumb, find the best plumb line that ensures the joint will be fully covered by the profile once in place.) Ensure the backing clips follow this line at setout.
- Using a level as a straight edge, place this on the wall adjacent to the backing clip and get it plumb and level.
- Once fully satisfied with alignment, peel a small amount of tape from the bottom end of the Universal Backing Clip. Screw the profile in place at least 100mm from the end of the clip, and then at minimum 300mm centres.
- Place the level/straight edge on the wall and apply a small amount of pressure along the full length of the backing clip whilst ensuring it is against the straight edge, working down or up the clip. This will provide sufficient initial bond between the wall and backing clip.
- Once all screws are in place, apply full pressure (minimum of 8kg) with bodyweight to fully bond the VHB tape to the substrate.
- All backing clip should stop a min of 50mm from end of wall or opening. This will ensure that any profiles installed at right angles do not interfere with each other (Fig 1.5).
- If using multiple Universal Backing Clips in a vertical line, they should be installed with a minimum gap of 5mm between consecutive clips and a maximum distance of 80mm between clips (Fig 1.6).



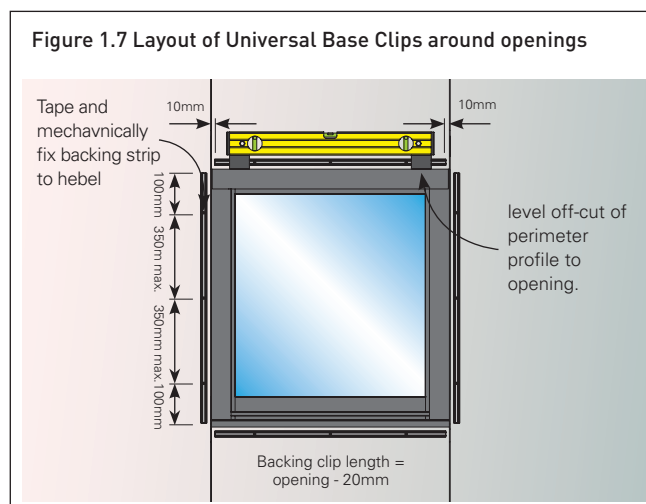
- Other Universal Backing Clips can also be installed in a similar manner. When installing all Universal Backing Clips, ensure that the next one is plumb and straight with the previous Universal Backing Clip that was installed.
- In all cases the Universal Backing Clips must be installed to follow a line. Using a long straight edge between backing clips ensures that this line is maintained between the backing clips. This is critical to ensure that the profiles and trims will clip into adjoining backing clips. A minimum 5mm gap between consecutive Universal Backing Clip should be maintained (Fig 1.6).



## 2.4.3 INSTALLING UNIVERSAL BACKING CLIPS AROUND OPENINGS

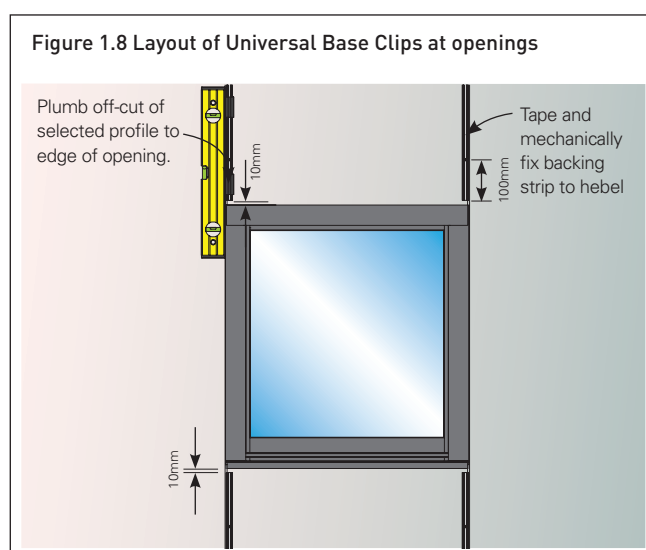
- Backing clips should typically be cut to the width or length (Fig 1.7) of the opening less 20mm (minimum) and no more than 50mm. (To ensure that backing clips will not extend past the opening and interfere with profiles and trims meeting at right angles at corner of opening.)
- Ensure the area is clean and dry commencing the application of backing clips.
- When installing backing clips around the opening use two small off-cut sections of the trim to provide a guide to (Fig 1.7) position the backing clip accurately. This will ensure that the trims aligns with the edge of the opening. (Keep these as templates for remaining installations. Removing any sharp edges off these off cut guides will make it easier to slide it along as noted in the next steps.)
- Check with level to ensure that the backing clip is plumb during installation. It is imperative that the trims meet accurately at 90 degrees so corner caps will fit over the adjoining trim.
- Backing Clips should be installed so as they are a minimum of 10mm in at each end of opening. (Refer diagram (Fig 1.10).
- Peel approximately 50-100mm of the backing tape from one end of the backing clip.
- Place the offcut trims 50-100mm in from each end of the backing clip and align with opening with the exposed tape end closest to the corner of the opening.

- Tack this end of the Backing clip 10mm in from corner of the opening with both ends of off cut trims aligned with edge of opening.
- Using a level, ensuring it is plumb and square with the opening.

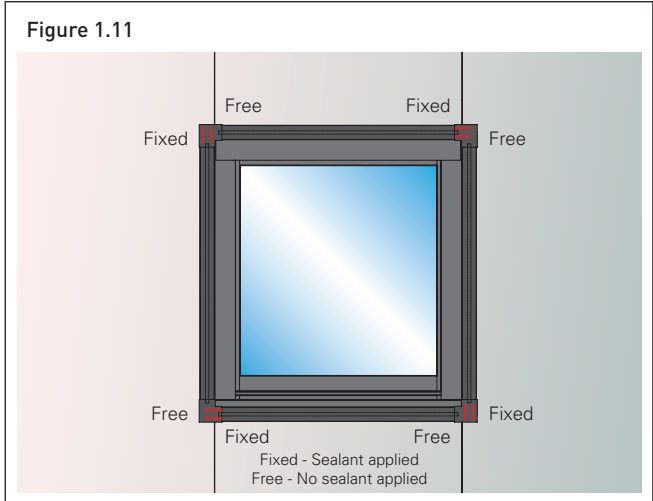
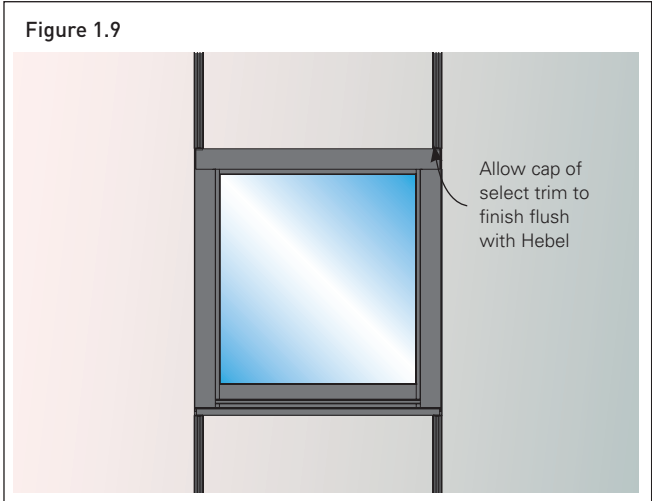


- Progressively peel of the remainder of the tape from the backing clip as you slide 2nd off-cut perimeter trim along the edge of opening ensuring it remains aligned with the opening, and lightly adhere the backing clip to the wall.
- Maintain the second trim slightly raised from the wall as you move the other trim towards it. This will allow you to peel more of the protective tape and adhere more of the backing clip to the wall.
- Check with the level to ensure the backing clip is plumb and level before applying full pressure to achieve full adhesion. Do this on all 4 sides or as many sides of opening as required as required and then screw into place.

NOTE: A square can also be used to check corners of opening are at 90 degrees (ie square). As noted above this will ensure that cover caps will fit over trims at corners.  
NOTE: Off cuts of Universal Backing Clips can be used to minimise wastage however, avoid using small lengths as this could create difficulty in maintaining alignment.

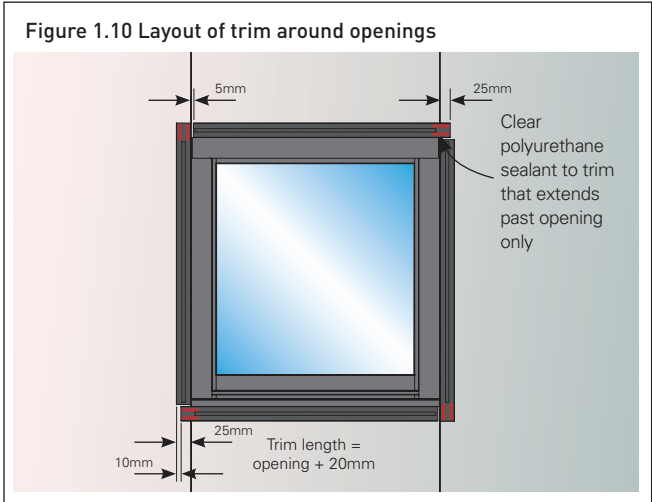






### 2.4.4 INSTALLING PERIMETER TRIMS AROUND OPENINGS ON TO THE PRE-INSTALLED BACKING CLIPS.

- Perimeter trims should be cut to the opening size + 20mm (Fig 1.10).
- Trims must be plumb and square to adjoining trims so corner caps will fit.
- The layout below should be adopted for gap spacings to allow for movement and expansion of trims which can occur with thermal movement in hot and cold weather. (5mm temporary packers can be used to easily achieve these gap spacings.)



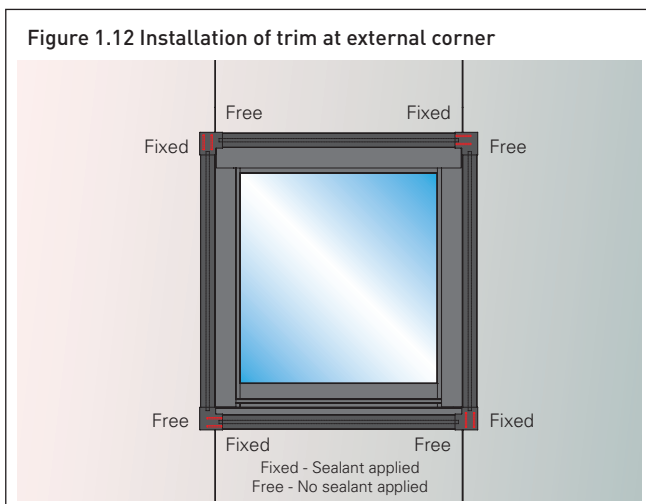
- The Perimeter Trim Cover Caps will hide any gaps and picture frame the opening.
- To lock in corner cover caps, a small amount of clear polyurethane sealant can be applied to the underside of the cover cap. Only flexible sealants should be used to adhere these. This is applied to one side of the cover cap only. This will always be the side that the perimeter trim extends beyond the opening (ie fixed side as noted in diagram).

### 2.4.5 INSTALLATION OF THE PROFILES

- Once all backing clips and perimeter trims are installed proceed to install vertical profiles.
- Vertical profiles are typically installed between a perimeter trim and a parapet trim. These vertical profiles should be measured carefully and cut to length.
- Where profiles run the full height of the wall these will typically run into the upper parapet trim which has been designed to allow for clearance for the profile in both the out of plane and in plane directions. This allows for cutting tolerance as well as expansion and contraction of long profile due to daily and seasonal temperature movements. Profiles meeting the parapet trim should be cut to the full height of the Hebel wall less 20mm.
- The vertical profiles below window openings are typically short runs and can be installed butting the perimeter trims at both ends. (These should be cut to provide a 1mm clearance to the adjoining perimeter trims to ensure they are not applying undue pressure to adjoining trims.

## 2.4.6 INSTALLATION OF THE TRIMS AT EXTERNAL CORNERS

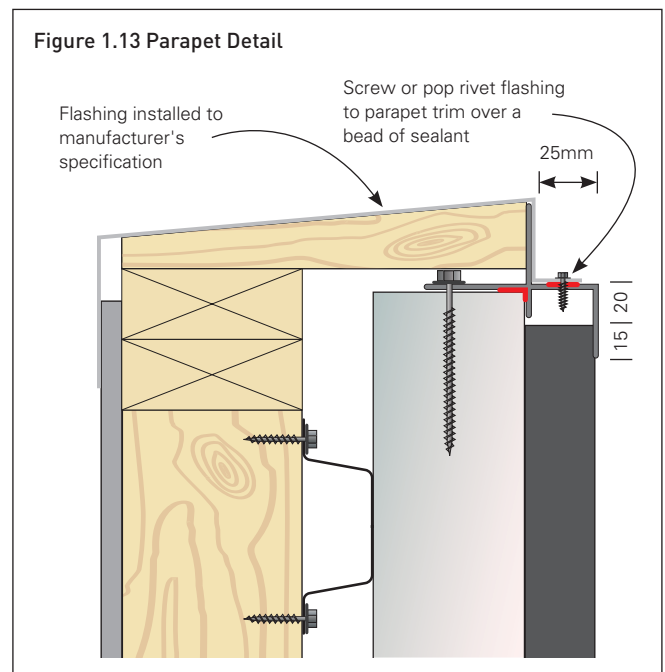
- When installing trim at external corners you should follow the process below to ensure the profile follows the panel edge along the entire length of the panel.
- Cut 2 small section of the trim you are installing and insert them 50mm -100mm in from each end of backing clip. Align this assembly with the control joint edge.
- Peel a small length of protective tape from one end of the Backing Clip then align both off-cut trims at each end with the outside edge of the panel and adhere the Universal Backing Clip (which has the protective tape removed) to the wall, ensuring the trim edge remains aligned with the panel edge at both ends.
- Slide the off-cut trim up approximately 200mm or so and continue to peel another section of the protective tape and adhere the backing clip as this is done. (Always ensuring that the trim aligns with the outside edge of the panel.)
- Repeat this process until reaching the opposite end of the backing clip.
- Next align the next backing clip using a straight edge and repeat the process using the off-cut trim to maintain alignment with the panel edge. (In all cases maintained a min 5-10mm space between consecutive backing clips)



## 2.4.7 INSTALLING THE TOP PARAPET PERIMETER TRIM.

The Parapet Trim is typically installed after all other profiles are in place. It is designed to also provide a fall and a fixing point for roof capping.

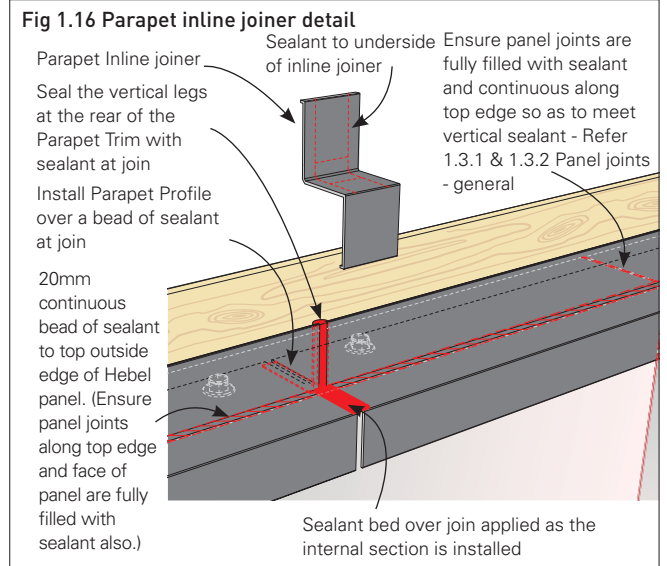
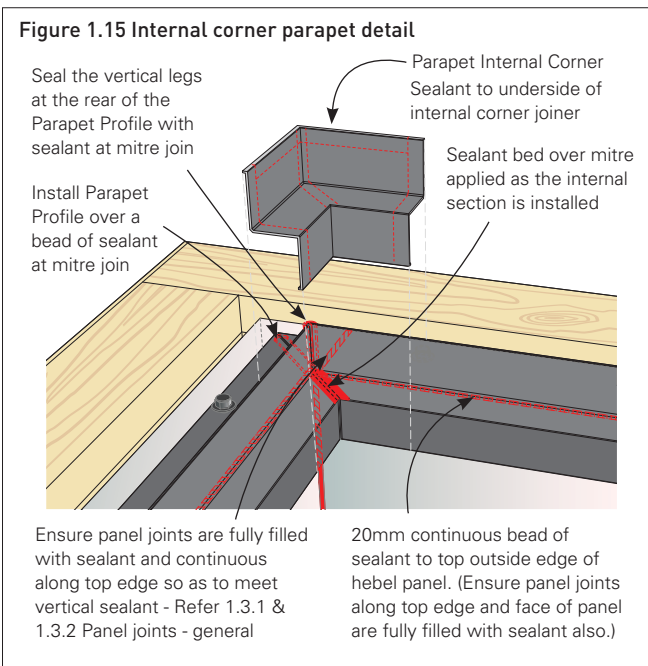
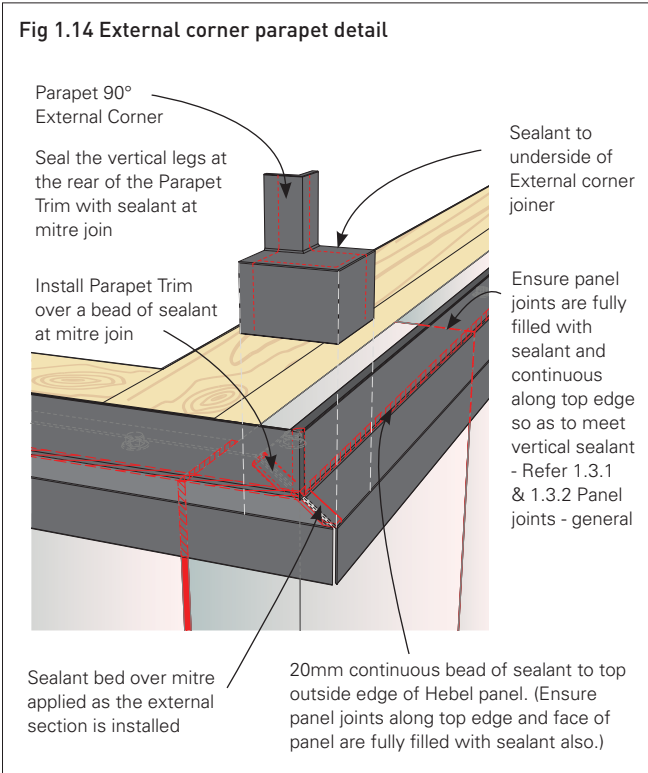
- The parapet trim must be installed level. It is important that the top of the wall is topped or trimmed level before painting if required.
- All corners should be cut at 45 degree mitre to form a 5-10mm control joint.
- A generous continuous bead of sealant must be applied to the top outside edge of the Hebel panel to weather seal the underside junction. (Ensure sealant does not show on underside of trim once installed Fig 1.16)
- This trim does not require a backing clip however it should be screwed off at approximately 600mm centres back to the centreline of the Hebel panel using 14-10x90 type 17 screws. All holes in the aluminium profile must be pre-drilled before screwing the profile in place.
- The Parapet flashing fixed by the roofing plumber to the horizontal face of the Parapet Trim using 10-16x16 tek screws c/w rubber washer or preferably using pop rivets. This fixing must align with the vertical profile location so as it is not easily visible from the underside. The return leg of flashing being fixed to the top of parapet trim should be no more than 25mm.



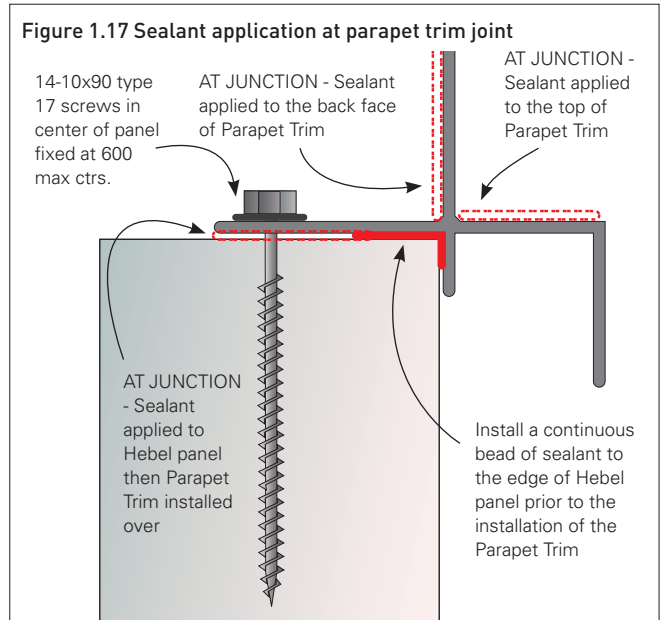
NOTE: Under atmospheric conditions of moderate to mild humidity, contact between a galvanized surface and aluminium is unlikely to cause substantial incremental corrosion. However, under very humid conditions, the galvanized surface may require electrical isolation from the aluminium. The use of a rubber washer will provide this isolation.

## 2.4.8 CORNERS

- A 10mm gap should be positioned at 6m maximum intervals between adjoining parapet trims and at corner junctions to ensure expansion and contraction of trims can occur. In these locations, cover caps are available to hide the gap and allow for this expansion and contraction. Ensure a sealant is applied as detailed at these locations, prior to installing the cover cap (Fig 1.16).

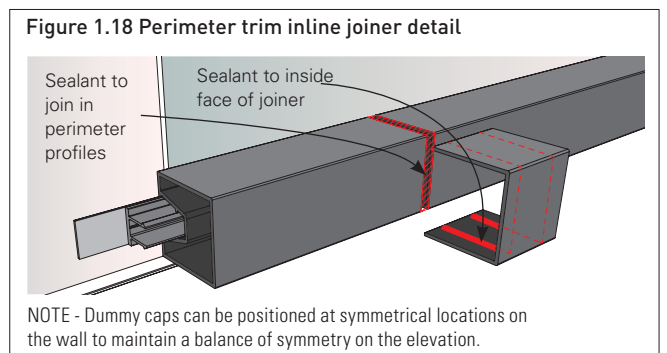


NOTE : Dummy caps can be positioned at symmetrical locations on the wall to maintain a balance of symmetry on the elevation.



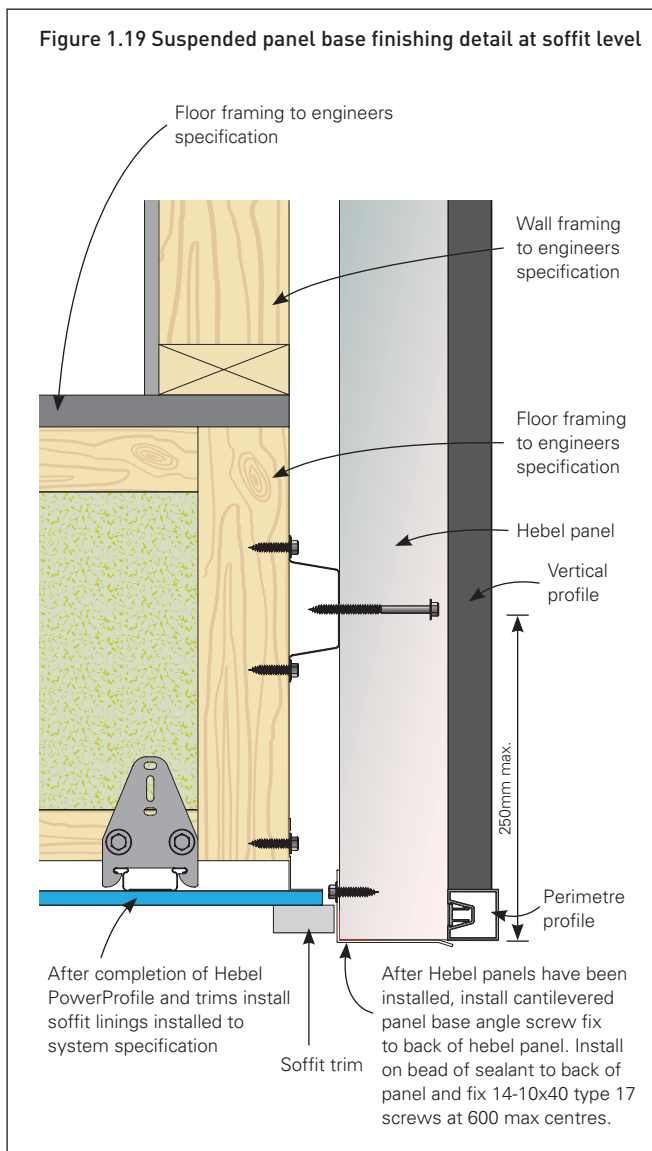
## 2.4.9 PERIMETER TRIM

- Similarly, the perimeter trims can be installed at maximum lengths of 4.8m. Longer lengths can be joined with a 10mm gap between trims. In these locations and at external corners perimeter cover caps are available to hide the gap and allow for expansion and contraction.
- Where cover caps are used, both sides of the cover cap should be fixed with application of a bead of sealant.



## 2.4.10 INSTALLING THE BASE ANGLE TO UNDERSIDE OF HEBEL SUSPENDED PANEL.

- The base angle is used to line the underside of Hebel panels and provide a neat return on the inside face. This allows for the ceiling / soffit lining to butt up to the inside of panels and minimises patching of joints and painting of both the underside and inside face of the Hebel Panels.
- The base angle can be installed using a small bead of sealant along the inside corner of the base angle. This will assist in temporarily supporting the angle in place and allow for minor packing and adjustment as required to create a plumb and level line. It can then be screwed off at 600mm centres directly to the inside face of the Hebel panel using 14G 10x65 type 17 Galvanised class 3 Screws at 600m centres. All holes in leg of aluminium Base Angle must be pre-drilled.
- The processes above must be followed prior to the Installation of adjacent soffit linings.



## 2.4.11 FIXING AND PATCHING BUTT JOINTS FOR WALLS GREATER THAN 3300MM IN LENGTH.

- Walls greater than 3300mm in height will require more than one panel. This will necessitate a butt joint between two panels to achieve the full height of the wall. In order to achieve the best possible result in hiding the butt joint within the coating system the panels should be carefully positioned to minimise any misalignment.
- Panels must also be fixed to horizontal battens within 150mm on both sides of this butt joint (Fig 1.19).
- Panel joint should be located no less than 900mm from the floor wall junction to minimise rotational effects on the joint (Fig 1.20).

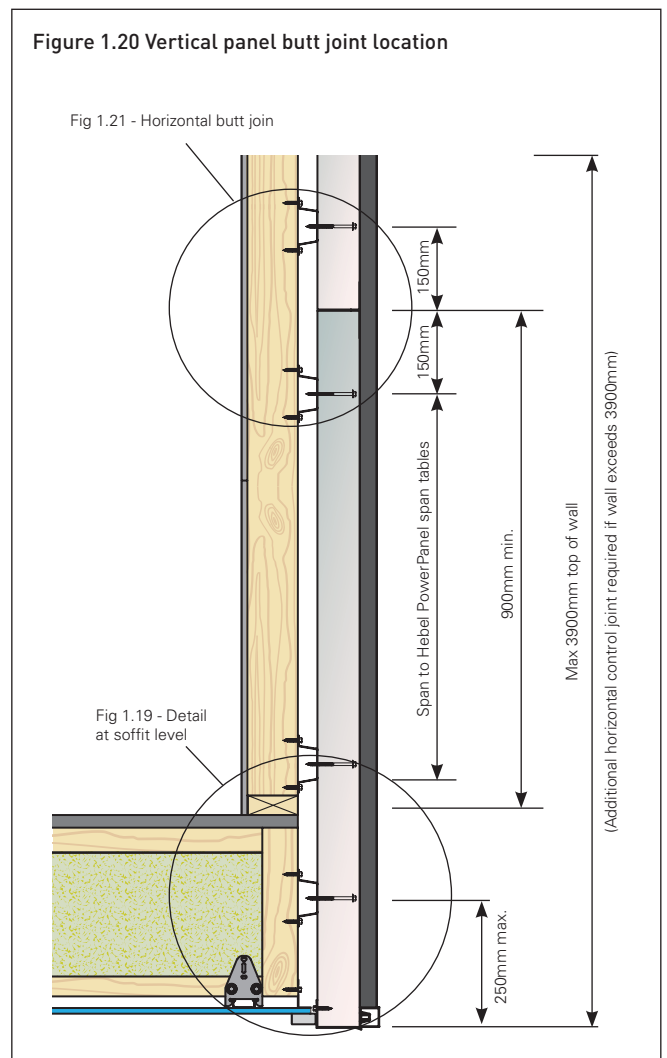


Figure 1.21 Vertical panel butt joint connection detail

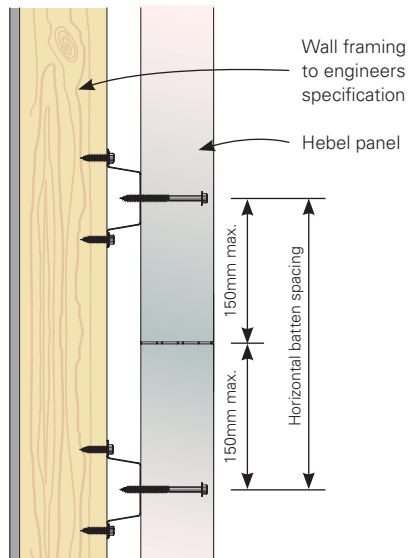


Figure 1.22 Trim at Eave

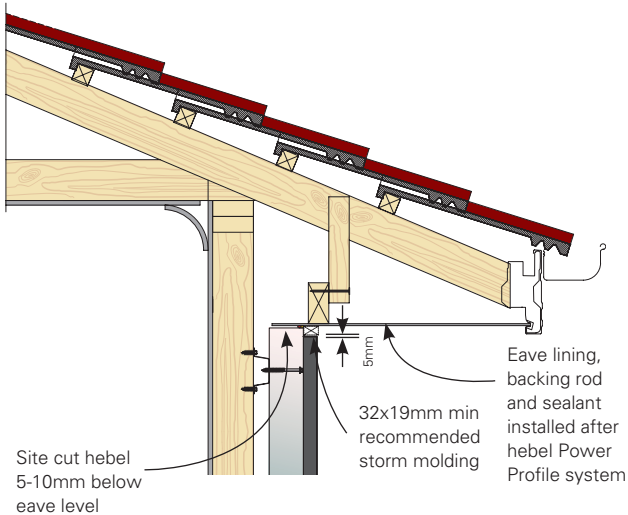
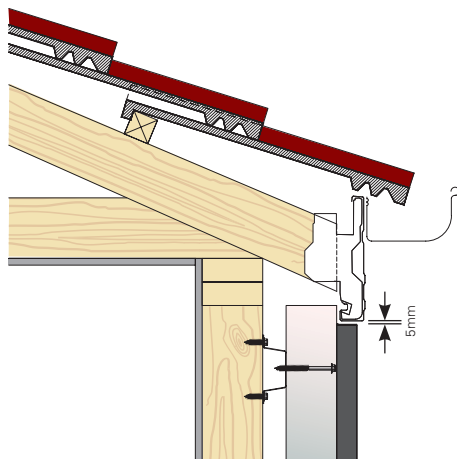
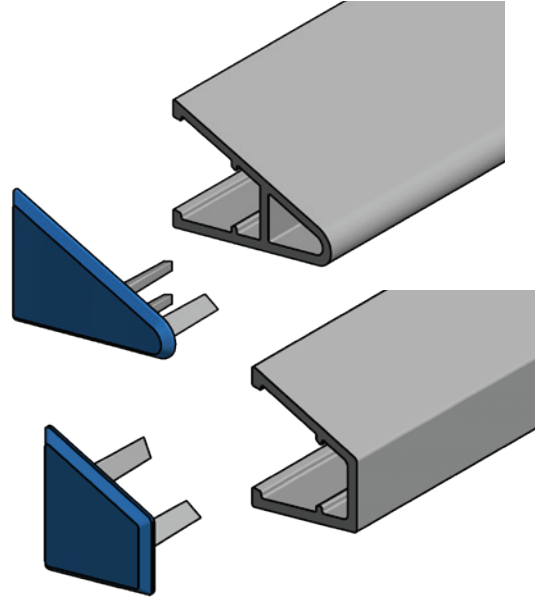


Figure 1.23 Trim at Zero Eave

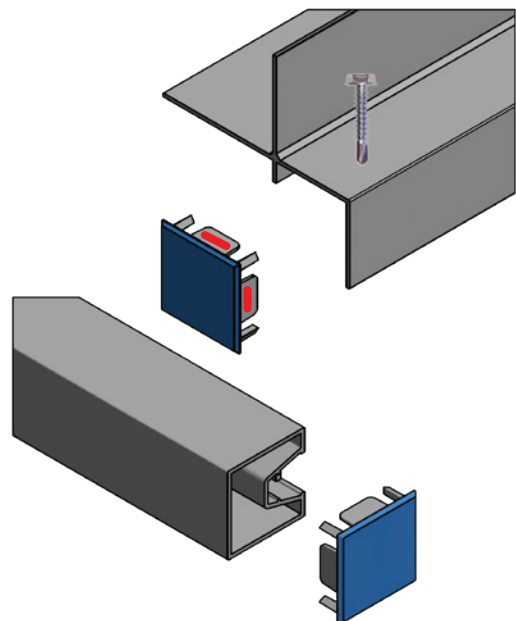


## 2.4.12 INSTALLING END CAPS

Where profile ends remain exposed, End Caps are available to close off the profile section. These should be installed using a small amount of clear sealant to the inside legs of the end cap.



The Parapet Trim uses the same end cap as the Perimeter Trim however, sealant should be applied to the two small flat legs. These should be rotated to butt against the legs of the Parapet Trim as shown below. The top leg can then be screwed off with a small Tek screw or pop rivet to hold the end cap in place.



# 3.1 DELIVERY AND STORAGE

## UNLOADING PANEL PACKS

Panel packs should only be unloaded and moved with approved lifting devices. Before use, the lifting devices should be checked for the required lifting tags. Packs should be unloaded as close as possible to the intended installation area. This will increase work efficiency and minimise the need for secondary lifting.

NOTE: Secondary handling increases the risk of panel damage. The repair of damage sustained during lifting and moving is the responsibility of the lifter. Where damage is excessive, PowerPanelXL panels must be replaced.

## STORAGE

All materials must be kept dry and preferably stored undercover. Care should be taken to avoid sagging or damage to ends, edges and surfaces.

All Hebel products must be stacked on edge and properly supported off the ground, on a level platform. Panel bundles can be stacked two high. The project engineer should be consulted as to the adequacy of the structure to support the stacked bundles.

If outside, Hebel panels must be stored off the ground and protected from the weather. Only single bundles positioned

on the ground can be opened. To provide a level surface, we recommend placing temporary joists beneath the supporting cleats.

## UNSTRAPPING PACKS

Ensure appropriate bracing is installed to packs prior to removal of strapping to prevent panels from falling. Panels can be held together with sash clamps, ratchet, straps or Hebel stabilising bars.

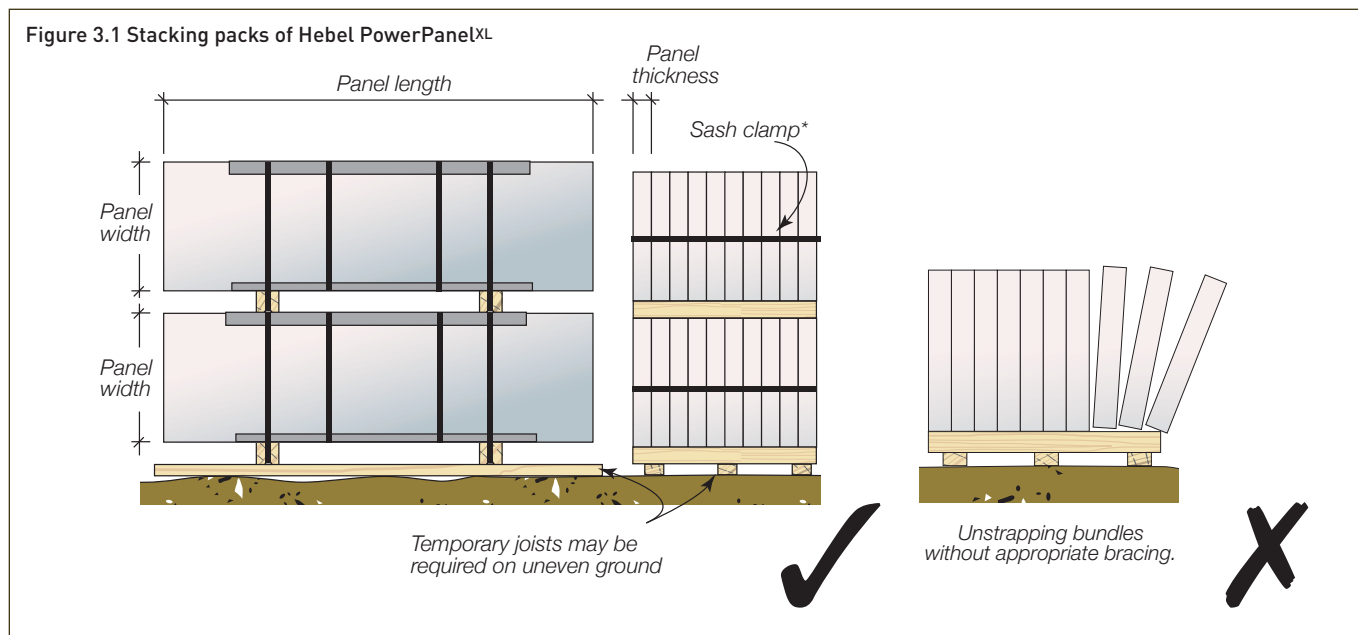


## STORAGE OF PROFILES, TRIMS AND ACCESSORIES

Profiles, Trims and Accessories must be kept dry during transit and storage. If stored outside, protect the product with a tarp and stack bundles clear of the ground to avoid the material getting wet.

## INSTALLATION CONSIDERATIONS

Consideration should be given to the activity of other tradespeople, in particular a brick cleaner. It is highly recommended that installation of the Profiles, Trims and Accessories be held off until the process of brick cleaning has been completed so as to avoid damage.



# 3.2 PANEL HANDLING

## MANUAL HANDLING

Hebel recommends using a trolley or other mechanical apparatus to move the PowerPanel<sup>XL</sup> panels around the work site. Manual handling where people physically move a panel should be kept to a minimum, with the weight being supported by an individual kept as small as possible. Any concerns regarding the weight to be handled should be discussed with the panel installation contractor.

To minimise the possibility of manual handling injuries, Hebel suggests the following:

- Use mechanical aids, such as trolleys, forklifts, cranes and levers, or team lifting to move panels
- Keep the work place clean to reduce the risk of slips, trips and falls, which can cause injury
- Plan the sequence of installation to minimise panel movements and avoid awkward lifts
- Train employees in good lifting techniques to minimise the risk of injury.

Figure 4.2.1 PowerPanel Trolley



## MECHANICALLY ASSISTED HANDLING

Moving and handling Hebel panels should be done as much as possible using mechanical aids such as forklifts, cranes and special panels lifting trolleys.

Guidelines for handling Hebel PowerPanel<sup>XL</sup> using the PowerPanel<sup>XL</sup> Trolley or PowerPanel<sup>XL</sup> lifters are detailed in The Hebel Technical Manual Part 6.

## HANDLING OF PROFILES, TRIMS AND ACCESSORIES

The Profiles, Trims and Accessories are a coated aluminium product and must be treated with care during handling so as to avoid damage to edges, ends and the surface. Being aluminium, they have sharp edges and gloves should be worn when handling items so as to prevent any potential injury.

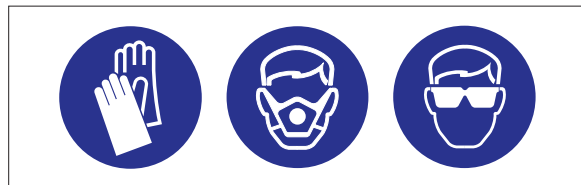
Consideration should be given to the activity of other tradespeople, in particular a brick cleaner. It is highly recommended that installation of the Profiles, Trims and Accessories be held off until the process of brick cleaning has been completed so as to avoid damage.

## HEALTH, SAFETY & PERSONAL PROTECTIVE EQUIPMENT (PPE)

Hebel products are cement-based, which may irritate the skin, resulting in itching and occasionally a red rash. The wearing of gloves and suitable clothing to reduce abrasion and irritation of the skin is recommended when handling Hebel products.

Approved respirators (AS/NZS 1715 and AS/NZS 1716) and eye protection (AS 1336) should be worn at all times when cutting and chasing. Refer to the Hebel Safety Data Sheets. Refer to the back of this Design & Installation Guide for further information regarding health and safety.

Figure 4.2.3 Personal protective equipment



## CUTTING

The use of power tools when cutting concrete products may cause dust, which contains respirable crystalline silica, with the potential to cause bronchitis, silicosis and lung cancer after repeated and prolonged exposure. When using power or hand tools on Hebel products, wear a P2 respirator and eye protection. When cutting, routing or chasing Hebel products with power tools, use dust extraction equipment and wear hearing protection. Refer to the appropriate Hebel MSDS. For further information, contact Hebel or visit the website: [www.hebel.com.au](http://www.hebel.com.au)

Reinforcement exposed during cutting must be coated with a liberal application of Hebel Anti-corrosion protection paint.

# 3.3 DESIGN, DETAILING AND PERFORMANCE RESPONSIBILITIES

Hebel engages independent testing laboratories to test and report on the performance of a wall in accordance with the relevant Australian Standards. Consultants use these reports as the basis for opinions (estimates of laboratory performance) they issue for variations or different arrangements to the tested system, and also to design and specify walls that meet appropriate criteria for a particular project. Using their experience, the consultant will make judgement about on-site installed performance of various walls. The performance levels of walls documented in this guide are either what is reported in a test or the documented opinion of consultants. Performance in projects is typically the responsibility of:

## PROJECT CONSULTANTS (STRUCTURAL, FIRE, ACOUSTIC, ETC.)

These consultants are typically responsible for the following:

- Opinions on expected laboratory performance of wall configurations that vary from actual test configuration, such as substitution products and components
- Judgements about expected field performance using laboratory test reports and practical experience
- Design, specification and certification of structural, fire, acoustic, durability, weather tightness and any other required performance criteria for individual projects

This involves the design and selection of building elements, such as wall and floors and their integration into the building considering the following:

- Interface of different building elements and to the structure / substrate
- Wall and floor junctions
- Penetrations
- Flashing issues
- Room / building geometry
- Acoustic and water penetration field-testing.

## PROJECT CERTIFIER AND/OR BUILDER

These professionals are typically responsible for:

- Identifying the performance requirements for the project in accordance with the National Construction Code and clearly communicating this to the relevant parties.
- Applicability of any performance characteristics supplied by Hebel including test and opinions for the project.
- The project consultant's responsibilities detailed above if one is not engaged in the project.

Hebel does not provide consulting services. Hebel only provides information that has been prepared by others and therefore shall not be considered experts in the field.

Any party using the information contained in this guide or supplied by Hebel in the course of a project must satisfy themselves that it is true, current and appropriate for the application, consequently accepting responsibility for its use.

It is the responsibility of the architectural designer and engineering parties to ensure that the details in this design guide are appropriate for the intended application.

The recommendations in this guide are formulated along the lines of good building practice, but are not intended to be an exhaustive statement of all relevant data.

Hebel is not responsible for the performance of constructed walls, including field performance, and does not interpret or make judgements about performance requirements in the NCC.



# APPENDIX A – DULUX ACRATEX COATING SYSTEM FOR CSR HEBEL POWERPROFILE

## ACRASHIELD LOW PROFILE TEXTURE ROLL ON SYSTEM OVER HEBEL POWERPANELXL

### Substrate:

CSR Hebel Autoclaved Aerated Concrete (AAC) is produced in panels for both load bearing and non-load bearing uses in various thicknesses, densities and designs relative to specification. The PowerProfile System consists of 75mm thick, steel-reinforced Hebel Powerpanel XL, AcraTex Coating System and Vertical Aluminium profile elements adhered to the super fine texture coated panel surface face using specially designed 3M VHB Adhesive Tape strips in accordance with the Hebel Design & Installation recommendations. Users of this specification will satisfy themselves of the suitability of this specification / advice, relevant to their specific project requirements. In all cases Building System Design must conform to relevant Local / Building Codes or regulations and be in accordance with substrate supplier's recommendations.

### Substrate Preparation:

Frame detail & panel fixing must comply with relevant building codes and be in accordance with CSR Hebel installation guidelines.

Dulux AcraTex recommends suitable expansion/contraction relief joints be installed at natural building weak points eg in line with openings (window / doors), horizontally between all floor levels, and at all interfaces of different building construction materials and or as defined by Engineer. All fixings must be non-corrosive, suitable for the exposure condition and be in accordance with substrate supplier recommendations.

### Panel Face Alignment & Panel Joint Glue Integrity

The PowerProfile system relies on Vertical Aluminium Profile being adhered to the finished coated panel surface face and as such panels MUST be installed true and flush. ANY deviation or panel step joints (misalignment) MUST be sanded flush prior to application of the specified thin build base skimcoat application. Failure to provide a level & flush panel-joint surface can lead to a higher build levelling system. The application of a higher build may introduce surface undulations of the finished coated panel face that could reduce contact and therefore achieve less than adequate adhesion of the backing clip to the coated panel face for the aluminium profile to then be fixed to.

It is the responsibility of the panel installers to ensure all panel joints or major imperfections are completely fill level and sanded level & flush before coating application can commence in accordance with CSR Hebel Design Guides. Panel Joints should be fully glued with Hebel adhesive struck flush at the panel face to provide a flushed & filled panel joint. Hebel Adhesive should not be smeared across panel faces. Substrate must be cleaned free of all surface contaminants prior to coating. Light sanding of the panel followed by dedusting with a clean water spray is recommended prior to coating.

### Control Joints:

Control Joints must be designed, installed & finished in accordance with CSR Hebel Design & Installation Guide including the incorporation of discontinuous top-hat sections across control joints and at corners. Doing this at design stage is the optimum time as it allows for size and positioning of opening to be considered with positioning and spacing of profiles.

Coating application over the paintable joint sealant can be achieved with the coatings system specified membrane coloured topcoat. Where movement of the control joints does occur, this can lead to potential coating cracking as a result of the joint design movement, where this does occur the coating will not be deemed a coating a failure.

Control joints are recommended between Floors and at breaks in Wall Frames, at all interfaces of different construction face materials and at (max.) 6m wide intervals. For control joints design specification & guidelines please refer to CSR Hebel for further details.

### Site Sample Reference

Prior to commencement of any works it is recommended that a reference site sample(s) area be done to for approval by the contractor and project decision makers. This is to provide an indicative typical example of the Hebel substrates condition, all substrate preparation, repair materials, control joint installation where applicable at junction points, specified coating, Aluminium Profiles installation, any additional surface voids & blemishes that can affect the desired aesthetic finish. Once approved this will become the job standard of the approved finished. Permissible variation and considerations shall be given of variation owing to any onsite restraints, scaffold limitations and angle or side light or illumination accentuating surface irregularities. Commencement of coating system application shall mean that the contractor is satisfied that the substrate is properly prepared and is ready to receive the specified coating(s) system.

### Aluminium Profile Detailing:

Standard Colour prefinished Powder coated details (Profiles, Joiner and End Caps) are available from CSR Hebel, in a choice of 3 Powder-coated colours Colorbond Monument, Basalt and Dune eliminating any on site painting of the profile details. Where non-standard colours are selected, the option of milled Aluminium profiles, joiners and end caps are available from CSR Hebel ready for painting prior to installation – refer to separate Duspec Coating Specification AUSA15579 for detail.

Duspec	AcraTex AcraShield Low Profile System for CSR Hebel PowerProfile Panel				Prepared By	Paul Augello		Page 1 of 5
Duspec No	AUSA15578	Issue No	5	Date	31.07.2020	Approved By	Ian Schultz	

#### DISCLAIMER:

Any advice, recommendation, information, assistance or service provided by any of the divisions of DuluxGroup Products in relation to goods manufactured by it or their use and application is given in good faith and is believed by DuluxGroup to be appropriate and reliable. However, any advice, recommendation, information, assistance or service provided by DuluxGroup is provided without liability or responsibility PROVIDED THAT the foregoing shall not exclude, limit, restrict or modify the right entitlements and remedies conferred upon any person or the liabilities imposed upon DuluxGroup by any condition or warranty implied by Commonwealth, State or Territory Act or ordinance void or prohibiting such exclusion limitation or modification. Coating systems can be expected to perform as indicated on the Duspec Spec Sheet so long as applications and application procedures of the individual products are followed as recommended on the appropriate Product data Sheet. The data provided within the Duspec system is correct at the time of publication, however it is the responsibility of those using this information to check that it is current prior to specifying or using any of these coating systems. This specification should be read in conjunction with the Product Datasheets specified within this document.

"Dulux" "Berger" "Berger Gold Label" "Hadrian" "Walpamur" "Levene" "AcraTex" are registered trademarks of DuluxGroup Pty Ltd ABN . 67 000 049 427



**Hebel Panel Coating System:**

CSR HEBEL Profile Panel Coating System	Data Sheet	Application Rate	Typical Recoat Time
<p><b>PRE-COATING PREPERATION TO SCREW FLUSHING &amp; SURFACE PATCHING</b></p> <p>Sand down any remaining panel joint miss alignment, all other repaired areas to remove any excess patching compound &amp; remaining surface blemishes to ensure the panel is left to an even level surface finish ready for coating application.</p> <p>Dedust &amp; clean to ensure the surface wall &amp; routed sections are left smooth, clean &amp; free of all surface contaminants.</p>			
<p><b>BASE LEVELLING SKIMCOAT WITH 200MM 165gsm WIDE JIONT MEST</b></p> <p><b>Panel Joint Mesh Installation:</b> Fix 165gsm alkali resistant 200mm wide mesh to all panel joints with stainless steel staples to ensure mesh is flat &amp; level with the panel face. Note: Ensure staples are not left protruding as this will affect skimcoat application.</p> <p><b>SKIM-BASE COAT: 1:1 AcraPatch HB blend with RenderWall P400</b></p> <p>Premix 20 kg bag of Renderwall P400 in accordance with the product data sheet to even consistency. Note this premix will amount to approx. 15LT in volume.</p> <p>Blend (1) Part AcraPatch HB 15LT <b>TO</b> (1) Part Premixed Renderwall P400 15LT Mix via electric mixing drill to even consistency.</p> <p>Note: Once the 1:1 of both products is completely mixed this should amount to approx. 30LT in volume of ready for use material.</p>	<p>Renderwall P400 AUDA01860</p> <p>&amp;</p> <p>AcraPatch HB AUDA0440</p>	<p>Minimum Spread Rate 0.6m<sup>2</sup>/Lt of the blended mix</p> <p>Subject to surface levelness</p>	<p>Minimum DFT 1.5mm</p> <p>Subject to surface levelness</p>
<p><b>1<sup>st</sup> COAT: AcraTex AcraShield Matt</b></p> <p>Apply with a Fine Cell Foam Texture Roller (typical cell count 30 cells per sq.inch such as an Oldfields ProSeries Superfine Texture Roller) to produce a fine even low profile stipple.</p> <p><i>see High Build Texture Roller Application Technique – following</i></p>	<p>AUDA1409 AUDA2510</p>	<p><i>2 sq m per litre</i></p>	<p>2 hours</p>
<p><b>2<sup>nd</sup> COAT : AcraTex AcraShield Matt</b></p> <p>Apply a second / final coat as per 1<sup>st</sup> coat</p> <p><i>see High Build Texture Roller Application Technique - following</i></p>	<p>AUDA1409 AUDA2510</p>	<p><i>2 sq m per litre</i></p>	<p>2 hours</p>

Duspec	AcraTex AcraShield Low Profile System for CSR Hebel PowerProfile Panel				Prepared By	Paul Augello	Page 2 of 5
Duspec No	AUSA15578	Issue No	5	Date	31.07.2020	Approved By	

**DISCLAIMER:**

Any advice, recommendation, information, assistance or service provided by any of the divisions of DuluxGroup Products in relation to goods manufactured by it or their use and application is given in good faith and is believed by DuluxGroup to be appropriate and reliable. However, any advice, recommendation, information, assistance or service provided by DuluxGroup is provided without liability or responsibility PROVIDED THAT the foregoing shall not exclude, limit, restrict or modify the right entitlements and remedies conferred upon any person or the liabilities imposed upon DuluxGroup by any condition or warranty implied by Commonwealth, State or Territory Act or ordinance void or prohibiting such exclusion limitation or modification. Coating systems can be expected to perform as indicated on the Duspec Spec Sheet so long as applications and application procedures of the individual products are followed as recommended on the appropriate Product data Sheet. The data provided within the Duspec system is correct at the time of publication, however it is the responsibility of those using this information to check that it is current prior to specifying or using any of these coating systems. This specification should be read in conjunction with the Product Datasheets specified within this document.

"Dulux" "Berger" "Berger Gold Label" "Hadrian" "Walpamur" "Levene" "AcraTex" are registered trademarks of DuluxGroup Pty Ltd ABN . 67 000 049 427



<p><b>System Upgrade Optional:</b></p> <p><b>Superfine/Smooth Finish:</b> Where an upgrade to a super fine/smooth finished panel face is preferred Dulux recommended that an additional coat of Sienna Naturale is applied over the completed thin skim/basecoat layer and floated to a smooth &amp; level finish.</p> <p><b>Surface blemishes &amp; voids after first coat of AcraShield:</b> After the first coat of AcraShield has dried the surface should be reviewed to determine if any additional make good is needed to any remaining surface voids &amp; blemishes that are evident that may not provide the desired outcome of the finished aesthetic appearance prior to the final coat being applied.</p> <p>Where this has been identified by the contractor and made aware to the project decision makers for consideration. Where nominated these surface voids &amp; blemishes can be made good using Selleys Spak Filla Rapid Exterior in accordance with the product instructions.</p> <p>Allow to dry and sand flush &amp; smooth and dust down – Do not leave raised edges.</p> <p><b>Selleys SPAK FILLA EXTERIOR RAPID    Product Code: 9300697110022</b></p>			
---	--	--	--

Duspec	AcraTex AcraShield Low Profile System for CSR Hebel PowerProfile Panel				Prepared By	Paul Augello		Page 3 of 5
Duspec No	AUSA15578	Issue No	5	Date	31.07.2020	Approved By	Ian Schultz	

**DISCLAIMER:**

Any advice, recommendation, information, assistance or service provided by any of the divisions of DuluxGroup Products in relation to goods manufactured by it or their use and application is given in good faith and is believed by DuluxGroup to be appropriate and reliable. However, any advice, recommendation, information, assistance or service provided by DuluxGroup is provided without liability or responsibility PROVIDED THAT the foregoing shall not exclude, limit, restrict or modify the right entitlements and remedies conferred upon any person or the liabilities imposed upon DuluxGroup by any condition or warranty implied by Commonwealth, State or Territory Act or ordinance void or prohibiting such exclusion limitation or modification. Coating systems can be expected to perform as indicated on the Duspec Spec Sheet so long as applications and application procedures of the individual products are followed as recommended on the appropriate Product data Sheet

The data provided within the Duspec system is correct at the time of publication, however it is the responsibility of those using this information to check that it is current prior to specifying or using any of these coating systems. This specification should be read in conjunction with the Product Datasheets specified within this document.

"Dulux" "Berger" "Berger Gold Label" "Hadrian" "Walpamur" "Levene" "AcraTex" are registered trademarks of DuluxGroup Pty Ltd ABN . 67 000 049 427

# High Build Roller Application Technique

## IT'S NOT PAINT

Because they are applied 3-5x thicker than standard paint, elastomeric coatings magnify any cut-in, roller edge and delivery unevenness.

## CUTTING-IN - WET

Thin cut-in material by 10% with clean water and cut-in only an area you can roll into wet. Finish brushed areas with a "dabbing" motion and feather out. DO NOT leave thick edge lines.

## DELIVER - SPREAD - LAY-OFF

- Deliver in overlapping strips - DO NOT leave "gaps" intended to even out on back-rolling as you may for paint.
- Reload the roller after each strip & repeat until a manageable section has been "delivered" (approximately 3-4 strips wide).
- Back-roll to spread the material evenly.
- Apply a fresh wet edge strip ahead of your work to create a "working wet edge".
- With an "empty" roller, "lay-off" by lightly rolling vertically in one downward direction to create an even finish.

### Work to a continuous pattern of:

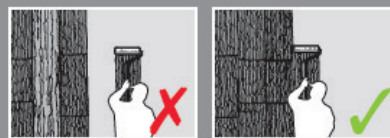
- 1 Cut-in wet & "Deliver" in 3-4 roller width strips.
- 2 "Spread" the strips out evenly.
- 3 "Deliver" a fresh strip to create a "working wet edge".
- 4 "Lay-off" the "spread" area.
- 5 Repeat the pattern keeping the "working wet edge" moving across the wall.

### 1 Cut-in only an area you can roll into wet



THIN cut-in material by 10%.

### 2 "Deliver" material to the wall in continuous strips



DO NOT leave gaps to back roll as you may for paint.

### 3 Spread evenly then "Deliver" a fresh wet edge strip



Back-roll to spread and even out.  
TIP: Applying a fresh edge strip ahead of your work before laying-off helps keep a wet edge in warmer weather or on larger areas.

### 4 Finishing (Laying-off)



Empty the roller and lay-off in one vertical direction downwards.  
TIP: Working with a partner so one person applies and the other finishes helps keep the wet edge moving across the wall. When working with a partner use a long nap roller for fast delivery and a shorter nap to lay-off for best finish.

## TIPS & TOOLS

**PROFESSIONAL** heavy duty roller frame and pole. High build coatings require more precise application of pressure to even out the thicker application.



**CORRECT** selection of roller sleeve. Texture Roller Sleeves can vary in cell size and firmness according to batch, their age and how they are stored. It is best to check and ensure you have a consistent supply of sleeves to complete the full project.

Ensure you "empty" the roller to lay-off or apply with a partner using a shorter nap roller to finish. If you can see lines or roller pattern wet it won't shrink back like paint.

**WET** cut-in only an area you can roll into whilst still wet. Thick dry cutting-in will show. Critically important in 1 coat applications.

**TEAM** the job. Working with a partner, one delivering, one laying-off produces the best results. Dependant on the size of wall and access, two or more people may be needed to make sure that there is a continuous application process across the entire wall.

**PLAN** applications in the cool of the day or in shade. This is critically important on larger walls. In hot and/or windy conditions, the addition of Hot Weather Thinner at the rate of up to 500ml per 15L will assist. In cold conditions the thicker application and heavy atmosphere requires more time and/or improved air movement to assist drying.

**ENSURE** there is sufficient stock of tinted topcoat material from a single tint lot to cover the full elevation or box multiple lots to ensure colour uniformity.

Duspec	AcraTex AcraShield Low Profile System for CSR Hebel PowerProfile Panel				Prepared By	Paul Augello		Page 4 of 5
Duspec No	AUSA15578	Issue No	5	Date	31.07.2020	Approved By	Ian Schultz	

#### DISCLAIMER:

Any advice, recommendation, information, assistance or service provided by any of the divisions of DuluxGroup Products in relation to goods manufactured by it or their use and application is given in good faith and is believed by DuluxGroup to be appropriate and reliable. However, any advice, recommendation, information, assistance or service provided by DuluxGroup is provided without liability or responsibility PROVIDED THAT the foregoing shall not exclude, limit, restrict or modify the right entitlements and remedies conferred upon any person or the liabilities imposed upon DuluxGroup by any condition or warranty implied by Commonwealth, State or Territory Act or ordinance void or prohibiting such exclusion limitation or modification. Coating systems can be expected to perform as indicated on the Duspec Spec Sheet so long as applications and application procedures of the individual products are followed as recommended on the appropriate Product data Sheet. The data provided within the Duspec system is correct at the time of publication, however it is the responsibility of those using this information to check that it is current prior to specifying or using any of these coating systems. This specification should be read in conjunction with the Product Datasheets specified within this document.

"Dulux" "Berger" "Berger Gold Label" "Hadrian" "Walpamur" "Levene" "AcraTex" are registered trademarks of DuluxGroup Pty Ltd ABN . 67 000 049 427



**Important Notes:**

It is recommended that the Applicator prepare a reference site sample for approval of the Project Superintendent demonstrating the finish relative to the actual project substrate installed and site conditions.

**Coatings must be applied in full accordance with relative product Technical, Application data sheets.**

**Refer to Material Safety Data Sheet for safe handling information**

This specification is to be read in conjunction with DULUX product data and application sheets and product Label detail.

Hebel panel must be installed flush and level otherwise steps across joints will be evident as the routed system design does not allow for making good of panel mis-alignment.

For highest level of surface finish, a trowel applied skimcoat of AcraPatch Smooth is recommended prior to application of coatings.

Practical spreading rates will vary from quoted theoretical figures depending on substrate porosity, alignment, surface roughness, alignment, overspray losses, application methods and environmental conditions (e.g. wind).

All preparation and painting must conform to AS2311: The Painting of Buildings

Plan for application on shaded surfaces, avoid hot windy condition or where rain is likely.

Do not apply products in direct sunlight or if the Relative Humidity is above 85% or temperature is within 3°C of Dew Point or where the surface temperature is greater than 30°C or below 10°C, or likely to fall below 10°C during the application or drying period. Allow longer times under cool, moist, or still conditions and or when applied at high film builds. Protect from dew, rain and frost for 48 hours when apply at the recommended spread rate.

Avoid application in hot, windy conditions or on hot surfaces cool the surface by hosing with water and paint the cool damp surface.

When using Bright Reds, Oranges, Blues and Yellows or where very light colours are applied over highly contrasting colours an extra coat maybe required. Application techniques should be adjusted to achieve the recommended DFT and finishing standard.

To avoid "Picture Framing" use only a 'wet on wet' cutting-in & coating technique incorporating masking taping of the perimeter of the application section.

COLOUR - Dark colours give rise to higher surface temperatures that may cause addition thermal stress and cooling demand to the building envelope and/ or require extra engineering considerations. Colours with a LRV greater than 35% are recommended for panellised construction.

LOCATION - The coastal area is considered a marine environment and as such salt potentially can shorten the life of the coating systems. Care needs to be taken to wash down all areas twice. Once to remove surface contaminants and raise salts to the surface and then secondly to remove these salts. Due to the locality, Weather conditions and lag time between applications of the coating system it may require the need to wash again, between coats.

GLANCING LIGHT - Joints and panel deformation may be more evident under glancing light, casting visible shadows of the minute and uneven projections of the joints. Such Glancing light is light that is nearly parallel to the surface of the wall and casts visible shadows and uneven projections of the joints. Imperfections seen and/or highlighted in critical glancing light conditions are not considered product or application defects and as such are outside the control / scope of this specification. Refer [www.dulux.com.au/applicator/technical-advice/preparation/glancing-light](http://www.dulux.com.au/applicator/technical-advice/preparation/glancing-light)

MAINTENANCE - The exterior texture coatings should be cleaned on a regular basis relative to conditions. Removal of surface contaminants will help maintain overall aesthetics and preserve your AcraTex Texture coating system. Fungi and Algae can exist on virtually any surface (even glass) provided the right conditions for growth are met and visible growth on painted surfaces is typically caused by contaminants on the surface together with the presence of high enough levels of moisture to support growth. Agents in paints that restrict mould growth become ineffective where they cannot "touch" the growth source (eg where growth emanates from deposits on the film). Refer : [www.dulux.com.au/content/dam/dulux/trade/pdfs/roofingcaremaintenanceguide201411.pdf](http://www.dulux.com.au/content/dam/dulux/trade/pdfs/roofingcaremaintenanceguide201411.pdf)

SURFACTANT LEACHING FROM EXTERIOR WATER-BASED COATINGS: Occasionally amber, clear or white spots/streaks are seen on a newly painted surface within the first few weeks after application. They usually appear after light rain or overnight dew and generally located in sheltered areas or areas with limited sun exposure. Under normal conditions surfactant contained in the tinted paint colour is slowly leached to the surface and washed away by rain leaving no trace and is a normal part of drying of any exterior water-based paint. Under certain atmospheric conditions and these surfactants leach or migrate to the paint surface, is concentrated forms and leaves clear or white deposits upon drying. These conditions include cool or humid weather or painting cold substrate and in most cases these marks on the wall surfaces are more noticeable on dark colours, such as browns or dark greens, etc. The clear/white surfactants that have migrated to the wall surface areas will cause no down grading nor performance changes or long term durability concerns of the paint films integrity and unfortunately have become an appearance issue instead. They easily removed from the paint film within a week or so of their appearance by washing with warm water & commercial grade detergent or via Nifti or Spray'n'Wipe followed by rinsing with fresh clean water. Under severe conditions they may reappear once or twice until all the surfactant has been removed. It will be less noticeable each time and can be removed in the same manner as before. Refer [http://www.dulux.com.au/pdf/tech-advice/DLX\\_TECH\\_Leaching.pdf](http://www.dulux.com.au/pdf/tech-advice/DLX_TECH_Leaching.pdf)

WARRANTY - A DULUX warranty can only be provided when the AcraTex system is applied by a DULUX AcraTex trained applicator, according to specification at the specified spreading rates and to the surface preparation details described in the DULUX AcraTex Specification Manual.

The dynamics of the substrate is outside the control of Dulux Australia and as such joint deformation or cracking is excluded from warranty terms. Refer warranty document for full terms and conditions.

When using this specification, the Installer shall maintain adequate records of proof or purchase and use of Dulux AcraTex Products

Duspec	AcraTex AcraShield Low Profile System for CSR Hebel PowerProfile Panel				Prepared By	Paul Augello	Page 5 of 5
Duspec No	AUSA15578	Issue No	5	Date	31.07.2020	Approved By	

**DISCLAIMER:**

Any advice, recommendation, information, assistance or service provided by any of the divisions of DuluxGroup Products in relation to goods manufactured by it or their use and application is given in good faith and is believed by DuluxGroup to be appropriate and reliable. However, any advice, recommendation, information, assistance or service provided by DuluxGroup is provided without liability or responsibility PROVIDED THAT the foregoing shall not exclude, limit, restrict or modify the right entitlements and remedies conferred upon any person or the liabilities imposed upon DuluxGroup by any condition or warranty implied by Commonwealth, State or Territory Act or ordinance void or prohibiting such exclusion limitation or modification. Coating systems can be expected to perform as indicated on the Duspec Spec Sheet so long as applications and application procedures of the individual products are followed as recommended on the appropriate Product data Sheet

The data provided within the Duspec system is correct at the time of publication, however it is the responsibility of those using this information to check that it is current prior to specifying or using any of these coating systems. This specification should be read in conjunction with the Product Datasheets specified within this document.

"Dulux" "Berger" "Berger Gold Label" "Hadrian" "Walpamur" "Levene" "AcraTex" are registered trademarks of DuluxGroup Pty Ltd ABN . 67 000 049 427

# APPENDIX B - ROCKCOTE COATING SYSTEM FOR CSR HEBEL POWERPROFILE

Specification ID 201008-114306



## HEBEL POWERPROFILE - XL PANEL - ARMOUR FLEX

**Application over:** Hebel PowerProfile - XL Panel

**Usage location:** External: Multi-Storey Wall(s):

### Surface preparation

Substrate must be clean and free of dust, dirt, oil, salt, mould or any other contamination. Patch any deep holes or imperfections with ROCKCOTE Quick Render Fibre Reinforced.

ROCKCOTE Rockbond 27 must be applied to the surface prior to the application of Step 1 to control absorption, improve adhesion, minimise joint grinning and allow a greater working time.

The moisture content in the substrate must be below 15% WME (Wood Moisture Equivalent) prior to and during the application of the specified ROCKCOTE Coating System.

**Important:** These systems are dependent on correct and straight installation of the cladding and the level of finish required. If walls require straightening, contact your ROCKCOTE representative for a custom solution.

ROCKCOTE recommends that on large broad wall areas where critical light is an issue, ROCKCOTE Masonry Primer Hi Op be applied prior to the application of ROCKCOTE Armour Flex to ensure uniform coverage and colour consistency.

It is crucial to the success of this system that Armour Flex is applied to the specified film build in order to achieve the required crack bridging capabilities.

**Success of the coating system is dependent on the patching of panels being carried out to a satisfactory standard prior to the application of the specified ROCKCOTE system. Patches may be visible through texture if poor patching techniques are used.**

**The substrate must be installed as per manufacturer's guidelines and specifications, this includes the installation of appropriate expansion, control, articulation and movement joints (hereafter referred to as relief joints). Refer to the substrate manufacturers installation manuals and guidelines for placement details of the relief joints. It is the responsibility of the Builder or Main Contractor to ensure all relief joints are installed as per the appropriate substrate manufacturers recommendations or the relevant Australian Standards, prior to the commencement of the coating application. It is the applicators responsibility that all coatings being applied do not impede or breach the relief joints.**

Please read all relevant Technical Data Sheets & Safety Data Sheets prior to product use.

### STEP 1

#### Quick Render Fibre Reinforced



<b>Application method:</b>	Trowel or Spray
<b>Spreading rate:</b>	3m <sup>2</sup> /20kg @ 4mm build
<b>Dry coating thickness:</b>	2-10mm
<b>Drying time:</b>	8 hours

### STEP 2

#### Masonry Primer Hi Op



<b>Application method:</b>	Brush or Long Nap Roller
<b>Spreading rate:</b>	6m <sup>2</sup> /ltr
<b>Drying time:</b>	2 hours

### STEP 3

#### Armour Flex



<b>Application method:</b>	Long Nap Roller
<b>Spreading rate:</b>	3m <sup>2</sup> /ltr
<b>Dry coating thickness:</b>	160 microns
<b>Drying time:</b>	6-8 Hours

### STEP 4

#### Armour Flex



<b>Application method:</b>	Long Nap Roller
<b>Spreading rate:</b>	3m <sup>2</sup> /ltr
<b>Dry coating thickness:</b>	160 microns
<b>Drying time:</b>	6-8 Hours

### Warranty information

The above specification is eligible for a 10 year system warranty when applied in accordance with the relevant technical specifications. ROCKCOTE warrants all its coatings and coatings systems when applied in accordance with the relevant technical specifications. This warranty not only ensures the client's protection but also ROCKCOTE's ongoing commitment to quality.



## CSR HEBEL

Triniti 3, 39 Delhi Road  
North Ryde NSW 2113, Australia  
Telephone +61 2 9235 8000

### Health & safety

Information on any known health risks of our products and how to handle them safely is on product packaging and / or the accompanying documentation.

Additional information is listed in the Safety Data Sheet (SDS). To obtain a copy of a SDS, download from [www.hebel.com.au](http://www.hebel.com.au). Contractors are required by law to perform their own risk assessments before undertaking work.

### Performance & certification

Hebel® products and systems are developed in Australia by CSR Building Products. ABN. 55 008 631 356. It is a manufacturer and supplier of Hebel Autoclaved Aerated Concrete (AAC) products. Because it is a manufacturer and supplier only, CSR does not employ people qualified as Accredited or Principal Certifiers.

CSR is therefore unable to provide Construction Compliance Certificates or Statements of Compliance. CSR conducts appropriate testing of its products and systems to determine performance levels. These include structural, fire and acoustic tests. Testing is conducted and certified by appropriate specialists in these fields. When using Hebel products and systems in specific projects, such specialists should be consulted to ensure compliance with the Building Code of Australia and relevant Australian Standards.

### Disclaimer

Information presented in this document is supplied in good faith and to the best of our knowledge at the time of preparation. Products are subject to natural variation as part of the manufacturing process and may vary from actual product in regard to colour and surface finish. Selected imagery has been computer generated and may also vary from actual product. The provision of this information should not be construed as a recommendation to use any of our products in violation of any patent rights or in breach of any statute or regulation. Users are advised to make their own determination as to the suitability of this information in relation to their particular purpose or specific circumstances. Since the information contained in this document may be applied under conditions beyond our control, no responsibility can be accepted by Hebel, or its staff for any loss or damage caused by any person acting or refraining from action as a result of misuse of this information.

### Other

The design of a wall, floor or fence system requires the services of professional consultants. This document has been prepared as a source of information to provide general guidance to those consultants – and in no way replaces the services of the professional consultant and relevant engineers designing the project.

No liability can therefore be accepted by CSR or other parties for the use of this document. Hebel products and systems undergo constant research and development to integrate new technology and reflect ongoing performance enhancement.

Hebel systems are constantly reviewed so as to reflect any changes in legislative building requirements and or general developments in common building practice, due to our commitment to continual development and improving our building systems.

We advise that all users of this document should regularly check that this document is current, and they are applying our latest design information.

The latest editions of our documents are available on our website:  
[www.hebel.com.au](http://www.hebel.com.au)

Hebel® is a registered trademark of the Xella group. CSR Building Products Ltd is an exclusive licensee of Xella. CSR Hebel is a business of CSR Building Products Ltd. ABN 55 008 631 356. PowerProfile® and PowerPanelXL are registered trademarks of CSR Building Products Limited. COLORBOND® and the ® colour names are registered trademarks and ™ colour names are trademarks of BlueScope Steel Limited.

## THE BETTER WAY TO BUILD

Hebel is a quality building product, and is backed by CSR Building Products Limited.

For more information visit our website:  
[www.hebel.com.au](http://www.hebel.com.au)

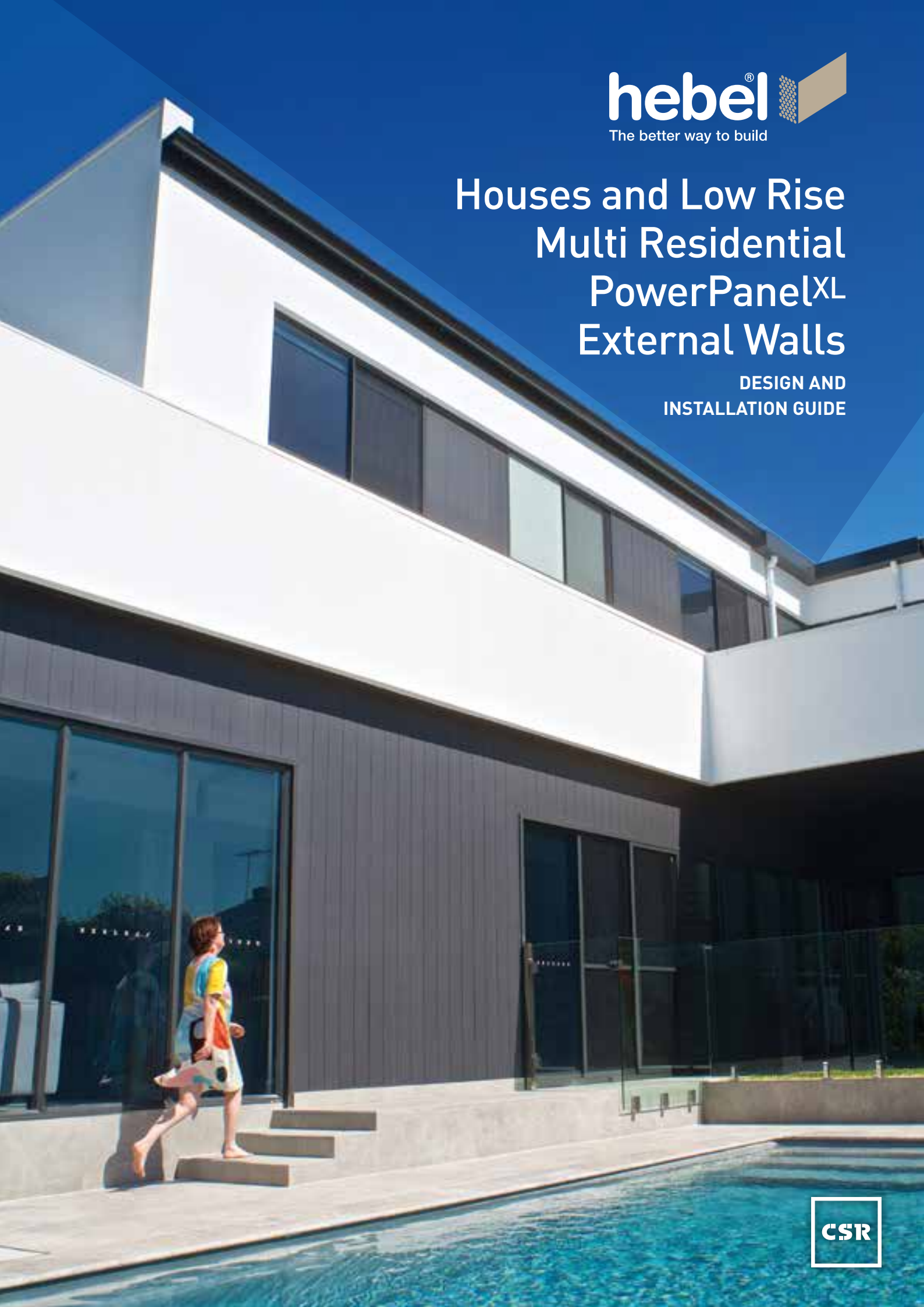
For sales enquiries or further information, please telephone us from anywhere in Australia:

1300 369 448



# Houses and Low Rise Multi Residential PowerPanelXL External Walls

DESIGN AND  
INSTALLATION GUIDE





# CONTENTS

This Design and Installation Guide has been prepared as a source of information to provide general guidance to consultants – and in no way replaces the services of the professional consultant and relevant engineers designing the project.

It is the responsibility of the architectural designer and engineering parties to ensure that the details in this Design and Installation Guide are appropriate for the intended application.

The recommendations of this guide are formulated along the lines of good building practice, but are not intended to be an exhaustive statement of all relevant data.

<b>Introduction</b>	<b>1</b>
<b>1. Design and selection details</b>	<b>4</b>
1.1 Designing an external wall using Hebel PowerPanel <sup>XL</sup>	4
1.2 Structural provisions	5
1.3 Design & detailing considerations	10
1.4 System components	12
<b>2. System performance</b>	<b>14</b>
2.1 Durability	14
2.2 Fire resistance performance	16
2.3 Energy efficiency	17
2.4 Sound transmission and insulation	21
2.5 Coating requirements	22
2.6 Weatherproofing	23
<b>3. Installation detail</b>	<b>24</b>
3.1 Hebel PowerPanel <sup>XL</sup> installation sequence	24
3.2 Tools and equipment for construction	25
3.3 Installation of services	25
3.4 External Aluminium render bead	25
3.5 Construction details – overview	26
3.6 Construction details	28
<b>4. Handling, storage and responsibility</b>	<b>49</b>
4.1 Delivery and storage	50
4.2 Panel handling	51
4.3 Design, detailing and performance responsibilities	53
<b>Appendices</b>	<b>54</b>
Appendix A: Hebel PowerPanel <sup>XL</sup> material properties	54
Appendix B: PowerPanel <sup>XL</sup> external wall system descriptions	55



Disclaimer: The photographs of houses included in this guide, while built from Hebel AAC panels, may not be constructed with the PowerPanel<sup>XL</sup> system.

# WHY HEBEL® SYSTEMS ARE A BETTER WAY TO DESIGN AND BUILD

Whether you're a developer, architect, designer, builder or wall installer, Hebel wall systems deliver exceptional advantages in terms of performance, quality, speed, efficiency, risk minimisation and sustainability values.

## Creating high performance buildings using Hebel PowerPanelXL

At the heart of the Hebel external wall system for houses and low-rise multi-residential projects is the Hebel PowerPanelXL - a 75mm thick steel reinforced panel made from autoclaved aerated concrete (AAC).

Developed and warranted by CSR, the Hebel PowerPanelXL can reduce heating and cooling loads on buildings and is non-combustible. It can be produced to the size needed, is easily cut, makes construction fast and efficient, creates minimal waste and is a better choice for the environment compared with concrete or brick.

As with all Hebel reinforced panel products, PowerPanelXL conforms to the Australian Standard for Reinforced Autoclaved Concrete (AAC), AS 5146.

## Construction speed and efficiency

The Hebel PowerPanelXL External Wall System speeds up the build process at the same time as delivering a superior finished product – a key reason why developers, builders and owner / builders choose Hebel. For instance, one standard Hebel panel is the equivalent of 75 traditional bricks, which means the walls of a 150m<sup>2</sup> home can go up in as little as three days when installed by experienced Hebel installers.

## Minimising risk

Hebel wall systems provide a solid foundation for risk minimisation in design and construction. They are tested, well proven and designed to achieve NCC fire and thermal compliance easily. Combining the non-combustible property of PowerPanelXL with advanced system designs, CSR Hebel delivers high value cost effective solutions that significantly reduce risk points in construction.

## Gaining high sustainability values

Hebel AAC is a durable inert product, made from raw materials in a process that minimises embodied energy. The low bulk density of Hebel AAC means less than a quarter of the resources in raw materials are used in its production than for concrete and bricks.

Waste in production is reduced through extensive recycling. Production waste, slurry and even the steam generated are all recycled back into the manufacturing process while waste steel and oil are recycled off site. Even the non-toxic citrus

based solvents used for cleaning are recycled. Onsite the combination of panel sizes designed to suit standard building modules and the ease of working with standard power tools means there is very little waste. This goes a step further when panels are made-to-order. Altogether, Hebel is one of the most environmentally responsible building materials for wall system construction.

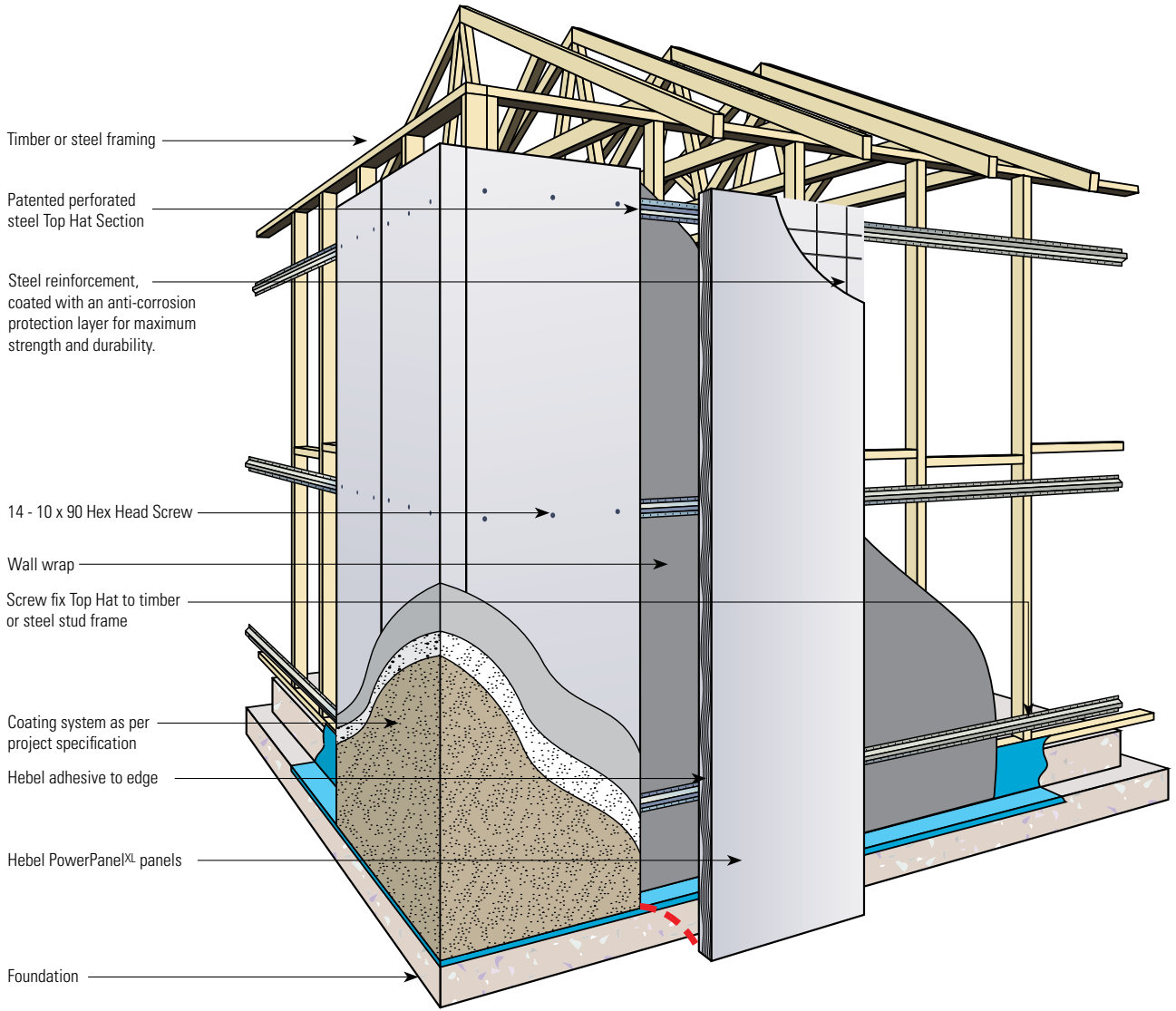
## Leveraging the exceptional value-add of Hebel systems

Quite simply the Hebel PowerPanelXL External Wall System for houses and low rise multi-residential projects delivers a holistic solution that no other systems can match. It benefits all stakeholders in the project lifecycle through its role in value-adding to the project's quality, design and construction efficiency, risk minimisation and cost and time certainty.



75mm steel reinforced Hebel PowerPanelXL. For fast construction with minimised waste, 600mm wide panels can be in ordered in stock lengths of 2400, 2550, 2700, 2800, 2850, 3000 and 3300mm.

Typical home construction application



The patented Hebel Perforated Top Hat for fast and robust installation.

# BENEFITS OF BUILDING WITH HEBEL



## STRONG AND SOLID

Hebel panels are high-performance building products made from autoclaved aerated concrete (AAC) containing steel reinforcement for added strength, with an anti-corrosion layer on the steel for maximum durability.



## ENERGY EFFICIENT

Hebel panels have superior insulation qualities compared to brick and concrete. Tests have shown a house built with Hebel PowerPanel<sup>XL</sup> performs better than brick veneer in terms of both heating and cooling. This can save the homeowner in heating and cooling energy costs.



## QUALITY AND SPEED

Building with Hebel can mean faster construction times, without sacrificing on quality. One standard Hebel panel is the equivalent of 75 traditional bricks, which means the external walls of a 150m<sup>2</sup> home can go up in just 3 days when installed by experienced Hebel installers. A high quality building material, Hebel provides a great solution in terms of speed and ease of construction which is why it is increasingly becoming the preferred choice of builders and developers.



## ECO-FRIENDLY

Independent testing shows that overall, Hebel has a 30% lower environmental impact than concrete or brick veneer. Hebel panels use 60% less embodied energy and produce 55% less greenhouse emissions compared to concrete or brick veneer, making it a more sustainable, environmentally friendly choice of building material.



## NOISE REDUCTION

A Hebel home is a quiet one. Building your home in Hebel can significantly reduce the noise transmission between rooms, and when used for floors, can reduce sound transference between levels as well. Compared to polystyrene and many fibre cement substrates, use of Hebel for external walls reduces noise from external sources like traffic, meaning more peace and quiet.



## FIRE RESISTANT

Hebel is renowned for its fire resistant properties, and is a non-combustible building material. Hebel systems have been tested by the CSIRO and are proven to achieve Fire Resistance Levels (FRLs) of 60 minutes through to 240 minutes – as well as meeting or exceeding the requirements for all six Bushfire Attack Level (BAL) categories. This makes it an ideal choice in bushfire zones.



## PROVEN

CSR Hebel is the only manufacturer of AAC in Australia. With over 25 years of experience in developing, testing and producing AAC you can be assured you're getting high quality products and systems and unmatched technical expertise with Hebel.

# 1.1 DESIGNING AN EXTERNAL WALL USING HEBEL POWERPANEL<sup>XL</sup>

## DESIGN PROCESS

This section outlines the design process for determining the adequacy of Hebel PowerPanel<sup>XL</sup> panel.

- STEP 1** Determine the wind category, stud framing layout and panel height requirements.
- STEP 2** Design Criteria. Where required identify the National Construction Code (NCC) Performance Requirements:
  - Fire Resistance Level (FRL).
  - Sound insulation performance ( $R_w$  values).
  - Energy efficiency (R-Value).
- STEP 3** The table below can be used to select a type, spacing and quantity of top hats and fixings to suit requirements.
- STEP 4** Select insulation and/or sarking material to suit energy efficiency and condensation requirements.
- STEP 5** Check adequacy of sound insulation and fire resistance level.
- STEP 6** Complete detailed design and documentation.

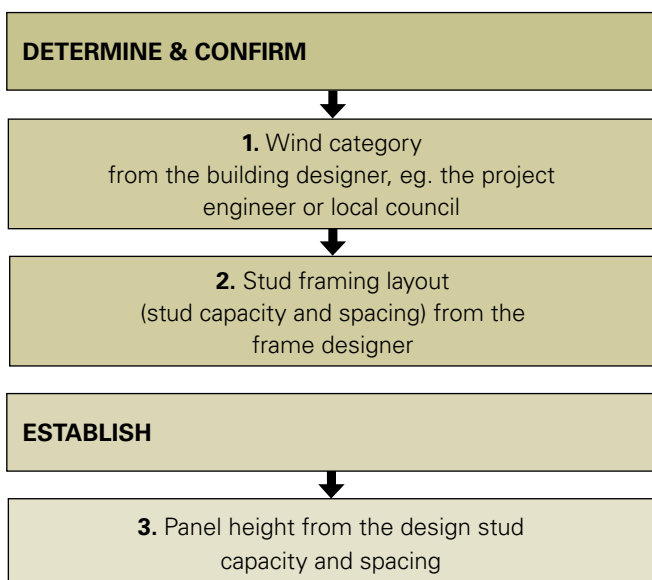


Table 1.1.1 Design process referencing

Determine	Table
No. of top hats	1.2.1 & 1.2.4
Max. stud spacing	1.2.1–1.2.5
No. of screws	1.2.2, 1.2.3 & 1.2.5
Corner effects	1.2.1–1.2.5
Control joint layout	Refer to control joints in construction details section

## COMPLIANCE WITH THE NATIONAL CONSTRUCTION CODE OF AUSTRALIA (NCC)

All building solutions such as walls, floors, ceilings, etc. must comply with the regulations outlined in the NCC or other authority.

The NCC is a performance based document, and is available in two volumes which align with two groups of ‘Class of Building’:

- Volume 1 – Class 2 to Class 9 Buildings; and
- Volume 2 – Class 1 & Class 10 Buildings – Housing Provisions.

Each volume presents Regulatory Performance Requirements for different Building Solutions for various classes of buildings and performance provisions.

These Performance Provisions include: Structure; Fire Resistance; Damp & Weatherproofing; Sound Transmission & Insulation; and Energy Efficiency.

This guide presents tables, charts and information necessary to assist in the design of a system incorporating Hebel PowerPanel<sup>XL</sup> that complies with the Performance Requirements of the NCC. The designer must check the adequacy of the building solution for Performance Requirements outlined by the appropriate authority.

## COMPLIANCE WITH AS 5146 REINFORCED AUTOCLAVED AERATED CONCRETE

All Hebel reinforced panel products conform with the Australian Standard for Reinforced Autoclaved Aerated Concrete (AAC), AS 5146.

The set of AS 5146 standards comprise of 3 parts:

- AS 5146 Part 1 – Structures
- AS 5146 Part 2 – Design
- AS 5146 Part 3 – Construction

These Standards are referenced in the Building Code of Australia making compliant AAC products Deemed-to-Satisfy (DTS) building materials.

AS 5146.3 – Construction, Section 4 contains details for 75mm reinforced AAC external walls in houses and low rise multi residential buildings, considered a DTS building system.

This provides the endorsement and confidence to regulatory and building certification bodies that the Hebel PowerPanel<sup>XL</sup> External Wall System is a NCC compliant construction system.

# 1.2 STRUCTURAL PROVISIONS

## OVERVIEW

The Hebel PowerPanel<sup>XL</sup> External Wall System consists of Hebel PowerPanel<sup>XL</sup> panels secured to the framing via horizontal steel top hats. This section provides the basic information on the selection of top hat spacings for a given stud spacing and wind category, as well as considerations to assist the designer in determining the appropriate wall configuration.

The design information presented in Tables 1.2.1 to 1.2.5 has been determined for 24mm and 35mm Hebel Perforated Top Hat section.

Minimum performance requirements for the metal studs, Hebel Perforated Top Hats, fixings and Hebel PowerPanel<sup>XL</sup> have been provided to assist the designer.

**IMPORTANT:** The design and approval of the structural framing (cold-formed steel or timber) is to be provided by the framing product manufacturer and/or project engineer.

## PRINCIPLES OF DESIGN

The principles on which the design is based include:

- a) The lateral wind loads applied to the panels are transferred into the horizontal top hats, then to the stud frame, which should be designed in accordance with the relevant Australian Standards for the imposed loads. The frame should be designed for all bracing and hold-down requirements.
- b) The design of the stud frame shall consider the weight of the suspended panels (such as the upper storey of two-storey construction).
- c) The system is not considered as cavity construction, as the Top Hat clearly bridges the cavity, hence the details show the necessity of sealing the windows and door frames, as well as applying a water resistant external coating.
- d) The system specifications vary with wind load. The notation used in AS 1684 Residential Timber Framed Construction has been adopted.
- e) The localised effects of wind around corners of buildings have been considered in the design and included in the tables. The extent of this effect is discussed towards the end of this section.

### Design Procedure

Design procedures for the verification of wall systems consisting of Hebel Autoclaved Aerated Concrete (AAC) PowerPanel<sup>XL</sup> panels generally follow the design principles outlined in Australian Standard AS 3600 – Concrete Structures for strength and serviceability design, with the exception of cover requirements for durability and development length for reinforcement.

The serviceability design of the Hebel PowerPanel<sup>XL</sup> panels has been carried out using the Transformed Section Theory, as detailed in the text book, 'Reinforced Concrete' by Warner, Rangan and Hall (Longman Cheshire). The load carrying capacity of the Hebel PowerPanel<sup>XL</sup> panels is influenced by several factors, such as:

- Imposed action (wind).
- Lateral stiffness of the supporting structure, lightweight structural, cold-formed steel framing.
  - Stud size and spacings.
  - Deflection limit.
- Height of the wall.
- Number and spacing of the top hats.
- Number of screw fixings considered effective.

### Criteria for corner panels

Due to the increase of wind load around the corners of buildings, extra top hats and screws may be necessary (N3 and greater) for a distance of 1200mm in each direction from the corner.

Tables 1.2.1 to 1.2.5 identify the installation criteria in these areas in the columns titled 'Panel Location – Corner'.

### Earthquake loads

Earthquake loading has not been considered in this design guide.

## DESIGN TABLES

This section presents tables to assist the designer in the selection of the number of top hats and number of screws for securing the Hebel PowerPanel<sup>XL</sup> panels to the framing for a given wind category.

### NOTES:

1. The wind category is to be used as a guide. The designer should check the project wind pressure against the values given in the tables.
2. Panels not tested for impact loading from windborne debris in Regions C and D as per AS1170.2. Building designer should allow for internal pressures resulting from dominant openings.

## STUD FRAME – STEEL OR TIMBER

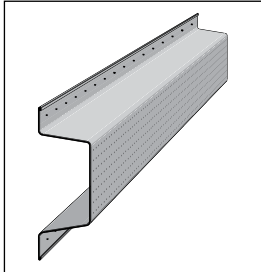
The stud frame shall be designed by the stud manufacturer or appropriate project engineer. Hebel PowerPanel<sup>XL</sup> panels are a steel reinforced AAC product and the support structure should be designed to provide sufficient stiffness.

The steel stud frame shall be designed and constructed in accordance with AS 3623 and AS/NZS 4600 (NCC Performance Requirement).

The timber stud frame shall be designed and constructed in accordance with AS 1684.

## HEBEL PERFORATED TOP HAT

Hebel Perforated Top Hats in galvanised steel are provided in nominal widths of 24mm and 35mm and have been designed and constructed in accordance with AS 3623 and AS/NZS 4600 (NCC Performance Requirement). The following tables are based on the 24mm and 35mm Hebel Perforated Top Hat section:



### 24mm Perforated Steel Top Hat section properties:

- Cold-formed perforated steel top hats
- Minimum thickness 0.42mm BMT
- Minimum yield strength 550MPa (zincalume)
- Coating class AZ150 (see Durability).

### 35mm Perforated Steel Top Hat section properties:

- Cold-formed perforated steel top hats
- Minimum thickness 0.55mm BMT
- Minimum yield strength 270MPa (Galvabond)
- Coating class Z275 (see Durability).

## PANELS SUPPORTED AT BASE

**Table 1.2.1 Number of top hats – panel supported at base (such as slab edge or shelf angle)**

Wind category	Ultimate wind pressure (kPa)		Stud spacing (mm)	Number of top hats per panel							
	Away from corners	Within 1200mm of corners		Panel length (mm)							
				≤ 2400		≤ 2700		≤ 3000		≤ 3300	
				Panel location		Panel location		Panel location		Panel location	
				Typical	Corner	Typical	Corner	Typical	Corner	Typical	Corner
N2	0.67/-0.62	-1.25	600	3	3	3	3	4	4	4	4
N3,C1	1.05/-0.98	-1.95	600	3	4	3	4	4	4*	4	5
N3,C1	1.05/-0.98	-1.95	450	3	3	3	3	4	4	4	4
N4,C2	1.56/-1.45	-2.90	450	3	4	3	5	4	5	4	6
N5,C3	2.30/-2.14	-4.27	450	4	5	5	5	5	6	5	6

\* One additional top hat is required when Hebel direct fix clips are used to support top hats.

#### NOTES:

1. Negative pressure indicates wind suction.
2. All top hats to be spaced evenly, with top and bottom top hats installed 250mm (maximum) from the end of the PowerPanel<sup>XL</sup>.
3. The bottom top hat may be installed 450mm from the bottom edge of the panel (distance measured from the centre of the top hat) for N2 and N3, C1 wind category, provided the amount of screws are installed as follows. 3 screws per top hat at typical panel locations and 4 screws per top hat at corner panel locations.
4. Additional top hats will be required below all window openings and above openings if a PowerPanel<sup>XL</sup> or sill block is to be installed in this location.
5. Corner panel location applies to a PowerPanel<sup>XL</sup> panel within 1200mm of corners.

**Table 1.2.2 Number of screws per panel at each top hat location – panel supported at base (such as slab edge or shelf angle)**

Wind category	Ultimate wind pressure (kPa)		Stud spacing (mm)	Number of screws per panel per top hat			
	Away from corners	Within 1200mm of corners		Panel location			
				Typical		Corner	
				Top hat location		Top hat location	
				Ends	Middle	Ends	Middle
N2	0.67/-0.62	-1.25	600	2	2	2	2
N3,C1	1.05/-0.98	-1.95	600	2	3	2	3
N3,C1	1.05/-0.98	-1.95	450	2	2	2	3
N4,C2	1.56/-1.45	-2.90	450	2	3	3	3
N5,C3	2.30/-2.14	-4.27	450	2	3	3	4

#### NOTES:

1. Type of screw used is 14-10x90mm hex head type 17 screw, fixed from outside the building.
2. Corner panel location applies to PowerPanel<sup>XL</sup> within 1200mm of corners.

# PANELS SUSPENDED FROM FRAME

**Table 1.2.3 Number of screws per panel at each top hat location – panel suspended at gable ends**

Wind category	Ultimate wind pressure (kPa)		Stud spacing (mm)	Number of screws per panel per top hat		Maximum spacing of top hat (mm)	
	Away from corners	Within 1200mm of corners		Panel location		Panel location	
				Typical	Corner	Typical	Corner
N2	0.67/-0.62	-1.25	600	2	3	800	750
N3,C1	1.05/-0.98	-1.95	600	3	4	800	600
N3,C1	1.05/-0.98	-1.95	450	3	4	800	650
N4,C2	1.56/-1.45	-2.90	450	4	4	800	450
N5,C3	2.30/-2.14	-4.27	450	4	4	600	350

**NOTES:**

1. Top and bottom top hats installed 250mm (maximum) from the end of the PowerPanel<sup>XL</sup> panel.
2. Top hats to be installed horizontally with panels to span vertically. Number of screws per panel per top hat information is not suitable for soffits or any other areas where the panel is not vertical.
3. Corner panel location applies to PowerPanel<sup>XL</sup> panels within 1200mm of corners.
4. Type of screw used is 14-10x90mm hex head type 17 screw, fixed from outside the building.

**Table 1.2.4 Number of top hats – panel suspended from framing (e.g second storey construction)**

Wind category	Ultimate wind pressure (kPa)		Stud spacing (mm)	Number of top hats per panel							
	Away from corners	Within 1200mm of corners		Panel length (mm)							
				≤ 2400		≤ 2700		≤ 3000		≤ 3300	
				Panel location		Panel location		Panel location		Panel location	
Typical	Corner	Typical	Corner	Typical	Corner	Typical	Corner				
N2	0.67/-0.62	-1.25	600	4	4	4	4	4	4	4	4
N3,C1	1.05/-0.98	-1.95	600	4	4	4	4	4	4	4	4*
N3,C1	1.05/-0.98	-1.95	450	4	4	4	4	4	4	4	4
N4,C2	1.56/-1.45	-2.90	450	4	4	4	4*	4	5	4	5*
N5,C3	2.30/-2.14	-4.27	450	4	5	5	6	5	6	5	6

\* One additional top hat is required when Hebel direct fix clips are used to support top hats.

**NOTES:**

1. Negative pressure indicates wind suction.
2. All top hats to be spaced evenly, with top and bottom top hats installed 250mm (maximum) from the end of the PowerPanel<sup>XL</sup> panel.
3. Additional top hats will be required below all window openings and above openings if a panel or sill block is to be installed in this location.
4. Corner panel location applies to PowerPanel<sup>XL</sup> panels within 1200mm of corners.

**Table 1.2.5 Number of screws per panel at each top hat location – panel suspended from framing (e.g second storey construction)**

Wind category	Ultimate wind pressure (kPa)		Stud spacing (mm)	Number of screws per panel per top hat			
	Away from corners	Within 1200mm of corners		Panel location			
				Typical		Corner	
				Top hat location		Top hat location	
Ends	Middle	Ends	Middle				
N2	0.67/-0.62	-1.25	600	2	2	2	3
N3,C1	1.05/-0.98	-1.95	600	2	3	3	4
N3,C1	1.05/-0.98	-1.95	450	2	3	3	4
N4,C2	1.56/-1.45	-2.90	450	2	4	3	4
N5,C3	2.30/-2.14	-4.27	450	2	4	4	4

**NOTES:**

1. Type of screw used is 14-10x90mm hex head type 17 screw, fixed from outside the building.
2. Corner panel location applies to PowerPanel<sup>XL</sup> panels within 1200mm of corners.



# PANELS FIXED TO DROP EDGE BEAM

**Table 1.2.6 Number of top hats per panel - drop edge beam fixing**

Wind category	Ultimate wind pressure (kPa)		Fixing spacing of top hat to concrete (mm)	Max. top hat spacing							
	Away from corners	Within 1200mm of corners		Panel length (mm)							
				≤ 2400		≤ 2700		≤ 3000		≤ 3300	
				Panel location		Panel location		Panel location		Panel location	
				Typical	Corner	Typical	Corner	Typical	Corner	Typical	Corner
N2	0.67/-0.62	-1.25	600	900	600	900	600	900	600	900	600
N3, C1	1.05/-0.98	-1.95	600	900	600	900	600	900	450	900	600
N3, C1	1.05/-0.98	-1.95	450	900	450	900	450	900	450	900	450
N4, C2	1.56/-1.45	-2.9	450	600	450	600	450	600	450	600	450
N5, C3	2.30/-2.14	-4.27	450	450	300	450	300	450	300	450	300

**NOTES:**

1. Top and bottom top hats installed 250mm (maximum) from the end of the PowerPanel<sup>XL</sup> panel.
2. Maximum end overhang of top hat to be 150mm.
3. Minimum concrete grade is 25MPa.
4. Corner panel location applies to PowerPanel<sup>XL</sup> panels within 1200mm of corners.
5. Ramset Ramplug DNP08 to be used to fix the top hats to the concrete drop edge beam. Screw selection and installation of fixings must be in accordance to manufacturer's requirements.
6. At each fixing point, two anchors are required. Minimum anchor spacing and minimum concrete edge distance to be 50mm.
7. Screws to fix panel to top hat to be in accordance to table 1.2.2.

## FIXINGS

Table 1.2.7 outlines the connection type and requirements for constructing Hebel PowerPanel<sup>XL</sup> detailed in this design guide.

NOTE: From Table 1.2.7, 14-10x90mm hex head type 17 screws are specified and recommended for fixing the Powerpanel<sup>XL</sup> panel to top hat sections from the outside of the building. Refer to Hebel Technical Update TU-017 where bugle head screws are desired to be used in lieu of the 14-10x90mm hex head type 17 screws for this connection.

The project engineer or framing manufacturer is responsible for specification of alternative details. The minimum performance requirement of the screw is:

- Minimum screw coating class in accordance with AS 3566: Class 3 (Refer Section 2.1 for Durability).

### Zero boundary wall installation

Where access is limited or unavailable for fixing the PowerPanel<sup>XL</sup> panel to the top hat section from the outside of the building, such as in zero boundary wall installations, then fixing of the panel from the inside of the building using 14-10x65mm hex head type 17 screws is permitted on the basis that one additional screw (to the number of screws noted in Tables 1.2.2, 1.2.3 & 1.2.5 is provided per panel per top hat connection. For more details refer to Figure 3.6.4.2 and Hebel Technical Update TU-018.

**Table 1.2.7 Screws types**

Type of screw	Application	Socket type
12-11x35mm hex head type 17 screw	Fix top hat to timber frame	5/16" hex mag. socket
10-16x16mm hex head self drilling screw	Fix top hat to steel stud frame (1.2mm BMT max.)	5/16" hex mag. socket
14-10x65mm hex head type 17 screw	Fix PowerPanel <sup>XL</sup> to top hat from inside of building (zero boundary application only)	3/8" hex mag. socket
14-10x90mm hex head type 17 screw*	Fix PowerPanel <sup>XL</sup> to top hat from outside of building	3/8" hex mag. socket

\* The screws fixing the PowerPanel<sup>XL</sup> panels to top hats are countersunk min. 5mm into the panel and filled with Hebel Adhesive

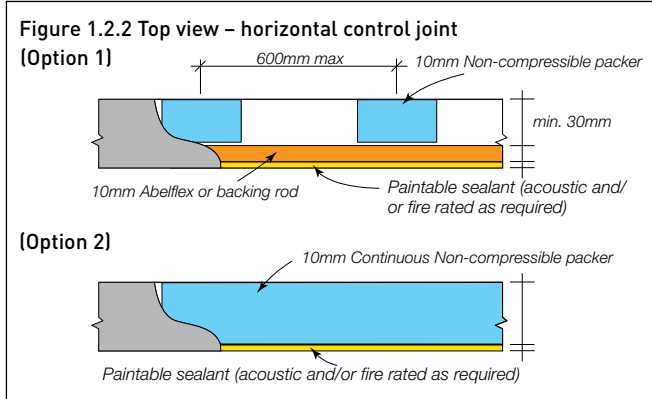
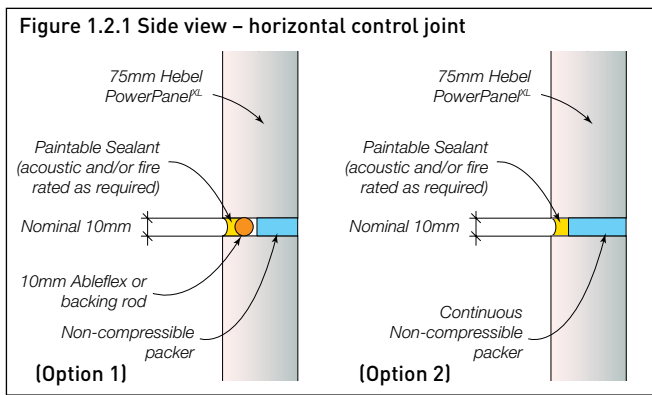
## STRUCTURAL FRAMING DESIGN

The use of Hebel PowerPanel<sup>XL</sup> in two-storey construction involves a number of design issues that require attention. In conjunction with the following, refer to the Construction Details in Section 3.6.

NOTE: When PowerPanel<sup>XL</sup> panels are suspended from the stud frame the project engineer shall design the frame to support the weight of the PowerPanel<sup>XL</sup> panels.

### Steel joists or engineered timber joists (≤1% shrinkage)

Lower storey panels are to bear on the slab edge. However, consideration should be given to the sectional size of the lintels over openings on the lower storey. As the details reveal, only a dummy control joint (nominal 10mm packers, backing rod and an external grade acoustic and/or fire rated paintable sealant joint) is required at the horizontal PowerPanel<sup>XL</sup> junction between the upper and lower panels. The panel support packer should consist of a durable material that will not degrade during the life of the structure.



NOTE: Use 10mm wide by 16mm deep CSR Fireseal or Fireblock XT Sealant at vertical and horizontal control joints to achieve FRL of -/120/120 for the wall system. See Section 2.2. Protect CSR Fireseal Sealant from rain until sealant has developed a thick skin. Once cured, CSR Fireseal should be painted over with a compatible external grade acrylic coating i.e. Dulux AcraTex or similar.

### Timber frame construction (>1% shrinkage joist).

Movements in the order of 25mm can occur in a two storey timber frame with a timber first floor. The fixing method used in the Hebel PowerPanel<sup>XL</sup> External Wall System does not allow for this extent of differential movement between the external skin and the timber frame.

The allowances for shrinkage of timber framing in NCC Vol. 2, by providing gaps between framing and masonry, should be adopted as a minimum.

It is therefore recommended that the upper storey PowerPanel<sup>XL</sup> panels be installed 35mm clear of the lower storey panels. During construction a temporary packer can be used to separate the panels and is then removed after the panels have been fixed. An architectural trim (feature moulding) must be used to hide the horizontal control joint. Contact Hebel Technical Services for further details.

The impact of this construction is to load the lower storey frame with the weight of the upper storey panels. In effect, an extra 44kg/m<sup>2</sup> (for the weight of the upper panels) is being added to the load already carried by the timber frame. The load approximates 1.05kN/m (2.4m wall height).

To simplify the design implications of this extra load, it is recommended to add an extra 1.4m of tributary width for a 90kg/m<sup>2</sup> tile roof load (for 2.4m upper wall heights) for the design of the lower storey frame and timber lintels, when using AS 1684. – cyclonic or non-cyclonic areas.

NOTE: Additional considerations should be undertaken for installation of the Hebel PowerPanel<sup>XL</sup> External Wall System onto copper treated timber including wall framing treated with CCA (Copper Chrome Arsenic). Contact Hebel Technical Services for more information.

### Bracing of the building

The walls of the dwelling should be braced using steel cross bracing wherever possible to allow the fixing of the PowerPanel<sup>XL</sup> panels without the need for additional packing. Ply or sheet bracing should be used on the external wall if the walls are too short for the steel cross bracing (refer AS 1684 – cyclonic or non-cyclonic areas). In this case, the full length of the wall should be sheeted to prevent misalignment of the panels.

Alternatively, localised strips of the sheeting can be fixed to the intermediate studs between the areas of full sheet bracing to maintain the panel alignment. All fixing is only from the outside, except on zero boundary walls. The extent of the bracing should be determined by the frame designer or project engineer.

NOTE: Minimum screw embedment depth into timber frame must be 25mm.

Table 1.2.8 Comparative wall thicknesses (mm)

Wall system	Wall element width			Total width
	Stud	Cavity	Masonry leaf	
Brick veneer	70	40	110	220
Hebel PowerPanel <sup>XL</sup>	70	24 – 35*	75	169 – 180*
Brick veneer	90	40	110	240
Hebel PowerPanel <sup>XL</sup>	90	24 – 35*	75	189 – 200*

\* NOTE: Depending on top hat selection

# 1.3 DESIGN & DETAILING CONSIDERATIONS

## BUILDING SETOUT

The Hebel PowerPanel<sup>XL</sup> External Wall System is principally designed for modular construction. The full benefit of savings in time and cost will be fully realised when the construction is designed to suit a 300mm module. In principle, thoughtful setout on the drawing board will minimise the site-cutting of the panels, which is time consuming and wasteful compared to the installation of stock PowerPanel<sup>XL</sup> panels.

### External wall height

Typically the external wall height is the distance from the base of the slab step down up to 50mm above the height of the eaves lining.

Window and door heights should also be considered when determining panel layout. Typically a 300mm distance below or above door or window heights is desirable.

### Wall length (horizontal dimensions)

Although not as critical as the wall height, the wall length designed to 300mm dimensions will help reduce waste.

## TERMITES

It is the builder's responsibility to ensure that all council and NCC requirements are fully adhered to in regard to the design of the house for preventing termite attack. The construction details contained in this guide do not attempt to fully address the issues due to the variation of requirements from state to state. Hebel PowerPanel<sup>XL</sup> is ideally suited to the exposed edge method of perimeter protection. NCC Vol. 2 deals with termite risk management and the reference code is AS 3660.

## FOOTINGS

Footings for Hebel PowerPanel<sup>XL</sup> should comply with articulated masonry veneer construction as specified in Australian Standard AS 2870. This is a minimum requirement. Local engineering advice should always be sought, especially in areas of highly reactive ground conditions.

## MOVEMENT CONTROL JOINTS

During the life cycle of a building, the building and the materials that it is constructed from will move. These movements are due to many factors working together or individually, such as support structure movement (lateral sway or vertical deflection), thermal expansion and contraction and differential movements between materials. This movement, unless relieved or accommodated for, will

induce stress in the materials, which may be relieved in the form of cracking. To accommodate these movements and relieve any induced stresses, which could potentially crack the wall, movement joints need to be installed.

- Control joints are provided to relieve the induced stresses resulting from thermal expansion or contraction of the AAC, or differential movement between the AAC and another material or structure, such as abutting walls or columns of concrete or brickwork. Control joints can delineate coating shrinkage breaks.

Vertical control joints should coincide with control joints in the supporting structure and anywhere that significant structural movement is expected, where the wall abuts a vertical structure, such as an existing building, or adjacent to large openings. Refer to control joints in **construction details section**.

Table 1.3.1 Spacing of vertical control joint based on site classification

Site Class	Vertical control joint spacing
A, S	6
M, M - D	5.5
H1, H1 - D	5
H2, H2 - D	4.5

Notes:

1. Refer to AS2870 for guidance on the site classification.
2. Where building on a site with a class P identification, advice should be sought from a structural engineer. Sites identified as class P can relate to a single or number of soil conditions that may affect the behaviour of the slab (i.e. mine subsidence, varying depths of fill, abnormal moisture conditions etc.) As such, the project structural engineer would normally design the slab according to these site specific features and upon advice from a geotechnical report. From this assessment the engineer can then relate the soil type back to class A, S, M or H type soils based on the extent of settlement/heave (particularly in clay type soils). The spacing of control joints required in the external walls can then be determined based on Table 1.3.1, above. Note: The location of control joints for class E sites should be determined by engineering principles and specified by the project structural engineer.

Important: Where installing Hebel external wall claddings on slab edge rebates for sites that contain saline soils, a clearance between the base of the panel and the finished ground level must be maintained to avoid contact of the panels with these soils. Where the slab edge rebate is rendered, it must be ensured that the DPC under the panel is cut flush with the external face of the panel to form a barrier between the slab edge rebate and the underside of the overhanging section of panel to prevent the rise of salts (from saline soils) through the slab edge render and into the panel.

This guide proposes minimum widths for the movement joints. The project engineer shall determine if the joints are sufficient to accommodate the movement of the specific project building. Typically, the vertical joint is nominally 10mm wide and filled with an appropriate backing rod and flexible sealant.

NOTE: At all control joints, the top hat should be discontinuous to allow for the effective movement of the building at these locations.

A horizontal control joint is required beneath slabs or angles to accommodate any expected deflection. The magnitude of the deflection must be verified by the building designer. Typically, the horizontal joint is nominally 10mm wide and filled with an appropriate external grade acoustic and / or fire rated paintable sealant. External aluminium render beads can be used as an option at horizontal control joints providing neat and consistent finished joints (Refer to Section 3.4).

## CONDENSATION

Condensation is a complex problem and can occur under a variety of conditions, not just cold conditions. Literature on this subject is available from CSIRO/BRANZ/ASHRAE and must be consulted when building in areas where condensation is likely to occur.

In these cases, the appropriate use of a sarking as a vapor barrier or as thermal insulation, or both, can be effective in controlling condensation.

## PENETRATIONS

Small service penetrations through the panel should allow for differential movement between the panel and the service. All penetrations are a potential source for water ingress and should be sealed with an appropriate acoustic and/or fire rated paintable sealant.

## WINDOWS

The builder should also ensure that the reveal size is correct to suit PowerPanelXL. Refer to Table 1.3.1 for recommendations.

The sizes below typically apply to aluminium framed windows. If timber windows are being used similar tolerances and guidelines apply.

Table 1.3.2 Reveal size

Stud size 70mm	
Top hat size	Reveal size**
24mm	100mm*
35mm	115mm
Stud size 90mm	
Top hat size	Reveal size**
24mm	120mm
35mm	135mm

\*Reveal sizes may vary from one manufacturer to another.

\*\*Figures shown assume brace board is used on framework.

NOTE: The external sealant in the control joints adjacent to windows must be retuned to the window frame, and sealant installed along the window head, sill and junction of the sides of the window to the panel. No gap should exist between the external sealant and the window frame.

## SUPPLEMENTARY CLADDING


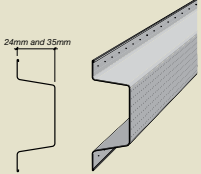





Supplementary cladding systems such as weatherboards and lightweight fibre cement may be installed over the top of the Hebel PowerPanelXL External Wall System. For more details please contact Hebel Technical services.









Photo courtesy of Danette Architecture.

# 1.4 SYSTEM COMPONENTS

The PowerPanelXL External Wall System is a complete system and Hebel stocks many of the products and materials required for your convenience.

Product	Description	Supplied by CSR Hebel																												
Hebel PowerPanelXL	<p>The core component of the Hebel PowerPanelXL External Wall System is the 75mm thick Hebel PowerPanelXL panel. The panel is manufactured in a range of stock sizes as detailed below:</p> <table border="1"> <thead> <tr> <th colspan="3">Panel weight (kg)</th> </tr> <tr> <th>Length (mm)</th> <th>Width (mm)</th> <th>Weight (kg) at 35% M.C.</th> </tr> </thead> <tbody> <tr> <td>2400</td> <td>600</td> <td>58</td> </tr> <tr> <td>2550</td> <td>600</td> <td>62</td> </tr> <tr> <td>2700</td> <td>600</td> <td>66</td> </tr> <tr> <td>2800</td> <td>600</td> <td>68</td> </tr> <tr> <td>2850</td> <td>600</td> <td>69</td> </tr> <tr> <td>3000</td> <td>600</td> <td>73</td> </tr> <tr> <td>3300</td> <td>600</td> <td>80</td> </tr> </tbody> </table> <p>NOTE: 75mm PowerPanel 1200 x 600mm weight 37kg. 75mm PowerPanel 1800 x 600mm weight 56kg.</p>	Panel weight (kg)			Length (mm)	Width (mm)	Weight (kg) at 35% M.C.	2400	600	58	2550	600	62	2700	600	66	2800	600	68	2850	600	69	3000	600	73	3300	600	80	✓	
Panel weight (kg)																														
Length (mm)	Width (mm)	Weight (kg) at 35% M.C.																												
2400	600	58																												
2550	600	62																												
2700	600	66																												
2800	600	68																												
2850	600	69																												
3000	600	73																												
3300	600	80																												
Top Hat	<p>Hebel Perforated Top Hats are used to fix the Hebel PowerPanelXL panel to the structural support framing. There are two nominal widths available: 24mm and 35mm – incorporating perforated flanges for ease of installation on to external wall frame.</p>	✓																												
Fasteners & Fixings	<p>Fixing of top hat to timber stud frame; 12-11x35mm hex head type 17 screw.</p>	✓																												
	<p>Fixing of top hat to steel framing; 10-16x16mm hex head self drilling screw.</p>	✓																												
	<p>Fixing of Hebel PowerPanelXL panels to top hat from inside of buildings 14-10x65mm hex head type 17 screw (zero boundary walls only). Refer to Table 1.2.7.</p>	✓																												
	<p>Fixing of Hebel PowerPanelXL panels to top hat 14-10x90mm hex head type 17 screw.</p>	✓																												
Hebel Direct Fixing Clip	<p>For attaching top hat to structural stud frame (zero boundary application only).</p>	✓																												

Product	Description	Supplied by CSR Hebel	
Hebel Mortar	Hebel Mortar (supplied in 20kg bags) when required is used as a thick bed mortar base to provide a level base for PowerPanel <sup>XL</sup> installation as well as providing acoustic and fire protection at the base of the panels.	✓	
Hebel Adhesive	Hebel Adhesive (supplied in 20kg bags) is used for gluing the PowerPanel <sup>XL</sup> panels together at vertical and horizontal joints.	✓	
Hebel Patch	Minor chips or damage to PowerPanel <sup>XL</sup> panels are to be repaired using Hebel Patch (supplied in 10kg bags).	✓	
Hebel Anti-Corrosion Protection Paint	To coat exposed reinforcement during cutting.	✓	
Hebel Base Sealer	For use when sealing the base of Hebel panels that may come into contact with soil levels (supplied in 5L tubs)	✓	
Hebel External Aluminium Render Bead (Optional)	Hebel External Aluminium Render Bead is used to provide neat and consistent horizontal control joints.	✓	

NOTE: CSR has engineered and tested the PowerPanel<sup>XL</sup> External Wall System to comply with the NCC and relevant Australian Standards. It cannot guarantee products and accessories not specified by CSR will perform to these standards. The Product Guarantee will only apply if all components used in the system are specified by CSR.

# 2.1 DURABILITY

## OVERVIEW

Durability means the capability of a building or its parts to perform a function over a specified period of time. It is not an inherent property of a material or component. It is the outcome of complex interactions among a number of factors, including:

- The service conditions
- Material characteristics
- Design and detailing
- Workmanship
- Maintenance

(‘ABCB Guideline Document – Durability in buildings: 2003’)

The following sub-sections of the durability topic are written in order to provide general guidelines on how best to provide, enhance and maintain adequate durability of Hebel PowerPanel<sup>XL</sup> panels.

## MAINTENANCE & ENHANCEMENT OF DURABILITY

The durability of the Hebel PowerPanel<sup>XL</sup> External Wall System can be enhanced by periodic inspection and maintenance. Inspections should include examination of the coatings, flashings and sealants. Paint finishes must be maintained in accordance with the manufacturer’s recommendations. Any cracked and damaged finish or sealants, which would allow water ingress, must be repaired immediately by recoating or resealing the effected area. Any damaged flashings or panels must be replaced as for new work.

The durability of the system can also be increased by using Class 4 fixings throughout, additional treatment of steelwork, and by painting all exposed sealants to the sealant manufacturer’s recommendations.

## COASTAL AREAS

Hebel PowerPanel<sup>XL</sup> panels can be used in coastal areas with additional precautions to ensure salt does not build up on the surface of the wall. For buildings up to 1000 metres from a shoreline or large expanse of salt water the following is required:

- All horizontal and vertical movement joints must be appropriately caulked; and
- All walls must be sufficiently exposed from above so that rain can perform natural wash-down of the wall; or
- Walls which are protected by soffits above must be washed down twice per year to remove salt and debris build-up particularly at the joints; and
- In all cases, Class 3 screws must be used.

NOTE: Class 3 screws must be countersunk in outer face of the PowerPanel<sup>XL</sup> by at least 5mm and filled with Hebel Adhesive.

## HEBEL CLADDING WHERE INSTALLED IN FLOOD AFFECTED AREAS

Hebel panels are an autoclaved aerated concrete (AAC) material containing macropores (i.e the air voids in the Hebel material structure) that create a porous structure. The panels are coated with an acrylic coating system generally comprising a base skim coat, texture coat and final coat layer to prevent the ingress of water from inclement weather.

Should Hebel external walls be subject to inundation by flood waters, this will likely affect and possibly breach the integrity of the external coatings and sealants causing the panels to absorb moisture. Although the mineral properties of the Hebel AAC material structure are generally unaffected by moisture, the integrity of the panels must be re-assessed following a flood event, by removal of the external coatings. It is likely that extended periods of inundation could cause long-term damage to the durability of panels (i.e manifested corrosion of reinforcement, damage from impact caused by flood debris etc), in which case, the affected panels should be removed and replaced.

For these reasons, best building practice would be to ensure that the base of panels remain within the freeboard region of the determined and site-specific flood level to avoid inundation, as Hebel AAC panel product warranties following exposure to a flood event are not guaranteed and are subject to the discretion of CSR Hebel.

## HEBEL POWERPANEL<sup>XL</sup>

Hebel PowerPanel<sup>XL</sup> has many characteristics which make it a very durable product, including:

- Will not rot or burn
- Is not a food source for termites
- Unaffected by sunlight
- Not adversely affected over normal temperature ranges
- One quarter the weight of conventional concrete
- Solid and strong with corrosion protection coated steel reinforcement.

## DURABILITY OF COMPONENTS

It is the responsibility of the building designer to ensure that the components such as screws, top hat battens and other steel components have the appropriate corrosion protection to be able to maintain their strength and integrity to suit the required design life of the project.

**IMPORTANT:** Termite treated timber frames (such as LOSP treated frames) may require sarking to prevent corrosion of steel components. Please refer to frame manufacturer for compatibility. CCA treated pine frames have a deleterious effect on the top hat coatings, which can lead to corrosion. Where timber is CCA treated, provide a barrier between top hat and timber member. Refer to frame manufacture for compliance with the frames compatibility with steel top hats and screw fixings.

When assessing durability the following documents can be referred to for guidance:

- ABCB Guideline Document – Durability in buildings: 2003.
- AS/NZS 2312: 2002 – Guide to the protection of structural steel against atmospheric corrosion by the use of protective coatings.
- ISO 9223: 1992 – Corrosion of metals and alloys – Corrosivity of atmospheres – Classification.
- AS 3566: 2002 – Self drilling screws for the building and construction industries.
- AS 2331 Series.

Reference to AS 3566 should always be adhered to when selecting the screw's corrosion resistance classification.

## WALL FRAMES

### Steel frames

The designer needs to ensure that the steelwork and Hebel AAC products have adequate protective systems to ensure that durability is maintained. The durability of the stud frame can be enhanced by the provision of a membrane such as sarking. The manufacturer of the steel stud frame can provide guidance on the appropriateness of this solution on a project-by-project basis.

**IMPORTANT:** The steel frame requirements outlined in the BCA Vol. 2, Part 3.4.2 should be considered in conjunction with steel frame design and construction advice from the steel frame manufacturer. These requirements consist of minimum protective surface coatings with restrictions on the location of the building and exposure condition of the steel frame.

### Timber frames

Information on the durability design of timber structures and components can be obtained from documents such as:

- AS 1720.1 Timber Structures, Part 1: Design Methods
- AS 1684 Timber Framing Code
- State timber framing manuals
- AS 3660 Subterranean Termites.



Photo courtesy of Metricon Homes



# 2.2 FIRE RESISTANCE PERFORMANCE

## OVERVIEW

The Hebel PowerPanel<sup>XL</sup> External Wall System can be subjected to a fire loading as the result of either an external fire source, or an internal fire source. When the wall requires a fire resistance level (FRL) rating, Hebel provides the following guidance:

### External fire source

For an external fire source, the excellent fire resistance qualities of the Hebel PowerPanel<sup>XL</sup> External Wall System protects the structural support framing and provides a high fire resistance level.

NOTE: The FRL rating of the wall can be affected by the penetrations and the method adopted to protect these penetrations. A fire collar with a –/60/60 FRL rating will govern the FRL of the wall, even if the wall configuration has a FRL rating of –/90/90. Where required, the performance of the external coating when subjected to a fire loading shall meet the appropriate performance requirements outlined in the NCC. Joints and gaps need to be appropriately fire rated, e.g. vertical control joint will need fire rated sealant and horizontal joints must be blocked with compressible fire rated material.

### Fire certificates and reports

Copies of the test reports and/or opinions can be obtained by contacting Hebel Technical Services. The Hebel PowerPanel<sup>XL</sup> External Wall System achieves a FRL of up to 180/180/180 minutes up to a maximum wall height limit of 3300mm per level. (CSIRO assessment report FCO-3003)

Only figures 3.6.4.1, 3.6.4.2, 3.6.4.4, 3.6.5.7, 3.6.6.5, 3.6.6.7, 3.6.6.8, 3.6.7.1, 3.6.7.2, 3.6.7.5, 3.6.7.9 and 3.6.7.10 in section 3.6 achieve a fire performance. Where other details are required to provide a fire performance or where a greater Fire Rating Level (FRL) is required, then assessment by a qualified fire engineer is necessary to verify such performance.

### Internal fire source

For an internal fire source the studs must be protected by the internal wall linings. The protective lining system can consist of CSR Gyprock Fyrchek<sup>TM</sup> plasterboard fixed to the support framing. The Hebel PowerPanel<sup>XL</sup> External Wall System can achieve an internal and external (two way) FRL of up to 120/120/120. For more details please contact Hebel Technical services.

### External walls in fire – NCC Provisions

Where necessary the designer and builder should ensure the structural support framing, its connections and the Hebel PowerPanel<sup>XL</sup> installation are satisfactory when subjected to fire conditions. The NCC Vol 2 outlines provisions for external walls for fire resistance in a residential building where the external wall is less than 900mm from an allotment boundary or 1.8m from another building on the same allotment. If this occurs an FRL of not less than 60/60/60 is required from the outside.

## FIRE PERFORMANCE OF HEBEL POWERPANEL<sup>XL</sup>

The Hebel PowerPanel<sup>XL</sup> External Wall System has been assessed by CSIRO to achieve a Fire Resistance Level (FRL) of up to 180/180/180. Note, the fire source is considered on the PowerPanel<sup>XL</sup> side. This enables Hebel PowerPanel<sup>XL</sup> to be used in the following applications:

- Walls on zero line allotment blocks.
- Multi-storey residential dwellings – external walls.

NOTE: In the above applications, each PowerPanel<sup>XL</sup> panel should be screwed as specified in this guide, except a minimum of three screws should be installed through the middle top hat into each PowerPanel<sup>XL</sup> panel.

## DESIGN CONSIDERATIONS

### Fire stop penetrations

Penetrations through Hebel PowerPanel<sup>XL</sup> to accommodate pipework, electrical cabling or ductwork will have to be protected (fire stop), to prevent the spread of fire through the penetration. The penetration can be protected with proprietary products such as:

- Fire rated sealants.
- Fire collars and intumescent wraps.
- Fire rated mortars.
- Fire rated pillows.
- Fire rated switch boxes.

Hebel recommends contacting the manufacturer to obtain the appropriate product/solution and installation method for the application and wall configuration.

## BUSHFIRE ZONE REQUIREMENTS

The Hebel PowerPanel<sup>XL</sup> External Wall System can achieve the construction requirements up to BAL - FZ as specified in Australian Standard AS 3959. When constructing in BAL - FZ a minimum setback distance of 10m from the edge of the classified vegetation is required. It is the responsibility of the building designer to ensure compliance to AS 3959 is achieved in accordance with clause F2.7.4 of NCC 2019 Volume 2.

# 2.3 ENERGY EFFICIENCY

## NATIONAL CONSTRUCTION CODE (NCC)

The NCC is available in two volumes which align with two groups of 'Class of Building':

- Volume 1 – Class 2 to Class 9 Buildings; and
- Volume 2 – Class 1 & Class 10 Buildings – Housing Provisions.

Each volume presents the Performance Requirements for the efficient use of energy for internal heating and cooling in buildings. The majority of changes have been associated with the Housing Provisions.

The Performance Requirements for energy efficiency ratings are dependent upon the form of construction (i.e. walls or floors), Class of Building, and the type of areas being separated. The performance requirement is a value that is the Total R-Value, which is the cumulative total of the individual R-Values of the building system components.

## THE HEBEL POWERPANEL<sup>XL</sup> EXTERNAL WALL SYSTEM

One of the primary design objectives in planning a building is to provide a cost effective comfortable living / working environment for the building's inhabitants. Exploiting the inherent thermal mass and insulation qualities of Hebel enables the designer to achieve this objective.

Several international comparative studies have been conducted to investigate the benefits of incorporating AAC walls in place of conventional wall systems. A common trend was the lower heating and cooling energy consumption and smaller mechanical equipment required to maintain a comfortable living environment, especially with regards to regions of mainly cold weather. The excellent performance was the result of the three characteristics – thermal mass, thermal insulation and the air tightness of the construction.

The level of insulation provided in a wall is determined by the required Total R-Value. The higher the required Total R-Value the greater the insulation provided. Hebel PowerPanel<sup>XL</sup> External Wall System incorporating CSR Bradford insulation can provide the R-Value ratings outlined in Tables 2.3.4 and 2.3.5.

## THERMAL INSULATION

It is recommended that insulation materials be installed to enhance thermal insulation properties and occupant comfort. Insulation also improves the acoustic performance of the wall against outside noise.

The NCC provides Deemed-to-Satisfy Provisions for compliance and installation of the various types of insulation. The insulation should be installed with Hebel PowerPanel<sup>XL</sup> such that it forms a continuous barrier to contribute to the thermal barrier. All insulation installed in Hebel PowerPanel<sup>XL</sup> External Wall systems must comply with: AS/NZS 4859.1; or AS 2464.3 for loose fill insulation.

## AIR TIGHTNESS

The thermal performance can be influenced by many factors. Most of these are related to the design decisions and properties of the adopted materials. Construction practices can also significantly affect the performance with poor sealing, resulting in drafts. The tight construction tolerances of AAC provide a wall with low air infiltration rate. Testing at the CSIRO (Test Report DTM327) on Hebel blockwork with thin bed adhesive joints has determined an air infiltration rate of 0.3L/s (0.014% of internal volume). For PowerPanel<sup>XL</sup> panels having fewer thin bed adhesive joints, a rate less than this could be achieved.

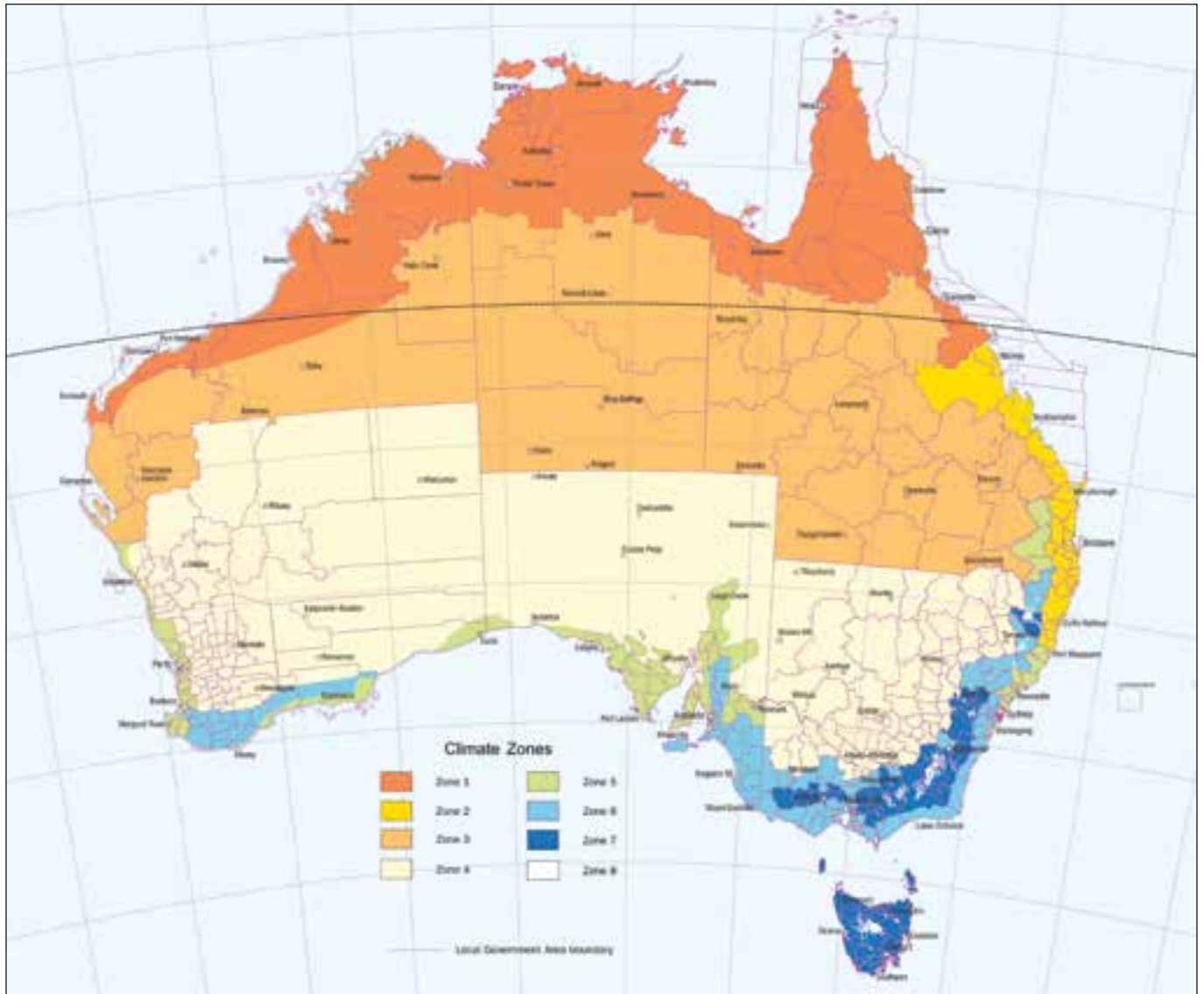
## SARKING

As well as controlling condensation and acting as an air barrier, sarking can be used to significantly improve the thermal insulation and energy efficiency performance of a building solution. Sarking layers can alter the performance of the cavity by providing a reflection side. The design of the sarking arrangement is complex and should be performed by the appropriate project consultant.

Where the sarking layer provides a weatherproofing function, the sarking material must comply with AS/NZS 4200 Parts 1 and 2.

The following tables show the performance levels required for walls and floors under the NCC and the thermal performance of the Hebel PowerPanelXL External Wall System.

Figure 2.3.1 Climate zones for thermal design



**STEP 1** Determine which climate zone your project is located in Australia from the map.

**STEP 2** From Table 2.3.1, determine the design conditions ('Summer' heat flow in or 'Winter' heat flow out) according to the building class and climate zone for your project. Note: Building classes are defined by the NCC.

**STEP 3** Refer to the roof, wall or floor system applicable to your construction type to determine Total R-Value.

NOTE: Some applications may achieve Total R-Values sufficient to comply with the minimum performance levels of the Deemed-to-Satisfy requirements contained in the Energy Efficiency Provision of the NCC.

Table 2.3.1 Climate zones for thermal design

Climate Zone	1	2	3	4	5	6	7	8
	Below 300metres		Above 300metres					
Class 1-10,2,3,4,9c	Summer		Winter					
Class 5,6,7,8,9a,9b	Summer						Winter	
Class 1-10	Summer		Winter					
Class 2,3,4,5,6,7,8,9a,9b,9c	Summer			Winter				

**Table 2.3.2 Low-rise multi-residential buildings**

Climate Zone	Options		
1, 2,3,4 and 5	(a)	(i)	Achieve a minimum <i>Total R-Value</i> of 2.8.
	(b)	(i) (ii)	Achieve a minimum <i>Total R-Value</i> of 2.4; and Shade the external wall of the storey with a verandah, balcony, eaves, carport or the like, which projects at a minimum angle of 15 degrees in accordance with Figure 3.12.1.2. of NCC 2019.
6 and 7	Achieve a minimum <i>Total R-Value</i> of 2.8.		
8	Achieve a minimum <i>Total R-Value</i> of 3.8.		

**Table 2.3.3 Comparison of thermal properties**

Products	R- Value
Fibre Cement 6mm	0.03
Brick 110mm	0.18
Hebel PowerPanel <sup>XL</sup>	0.52 (based on 8.15% moisture content)
Systems	R- Value
Brick veneer (double sided reflective foil)	1.77
Hebel1726 (double sided reflective foil)	2.16

0      0.5      1.0      1.5      2.0      2.5

NOTES:

- Sarking or insulation to be added to the above values where applicable to comply with NCC climate zone requirements.
- R-Values above (excluding Hebel PowerPanel<sup>XL</sup> solution) are taken from NCC 2019.
- Refer to Table 2.3.4 and 2.3.5 for Hebel PowerPanel<sup>XL</sup> configuration and thermal insulation options.
- R-Values provided for brick veneer have been provided by James Fricker calculation 107.50 dated July, 2010.

**Table 2.3.4 Thermal performance of Hebel PowerPanel<sup>XL</sup> External Wall System - timber stud frame**

Hebel code	Description						Total R-value m <sup>2</sup> .K/W	
	Platerboard	Stud frame	Batts	Wall wrap	Top hat cavity	Hebel Panel	Summer	Winter
Hebel1716	10mm Gyprock Plasterboard Plus	70mm timber Stud frame	None	Polyair Performa 4.0 XHD	24mm	75mm thick Hebel PowerPanel <sup>XL</sup>	2.13	2.16
Hebel1752			None	Thermoseal Wall Wrap Prime			1.55	1.59
Hebel1753			75mm Bradford Gold Wall Batts R1.5	Thermoseal Wall Wrap Prime			2.23	2.36
Hebel 1717			70mm Bradford Soundscreen Batts R2.0	Thermoseal Wall Wrap XP			2.89	3.01
Hebel1718			70mm Bradford Soundscreen Batts R2.0	Enviroseal ProctorWrap RW			2.55	2.66
Hebel1721			None	Polyair Performa 4.0 XHD	35mm		2.13	2.16
Hebel1754			None	Thermoseal Wall Wrap Prime			1.55	1.59
Hebel1755			75mm Bradford Gold Wall Batts R1.5	Thermoseal Wall Wrap Prime			2.23	2.36
Hebel1722			70mm Bradford Soundscreen Batts R2.0	Thermoseal Wall Wrap XP			3.00	3.13
Hebel1723			70mm Bradford Soundscreen Batts R2.0	Enviroseal ProctorWrap RW			2.65	2.77
Hebel1726		90mm timber Stud frame	90mm Gyprock Plasterboard Plus	None	Polyair Performa 4.0 XHD	24mm	2.13	2.16
Hebel1760				None	Thermoseal Wall Wrap Prime		1.55	1.59
Hebel1762				90mm Bradford Gold Wall Batts R2.0	Thermoseal Wall Wrap Prime		2.67	2.83
Hebel1727				90mm Bradford Gold Wall Batts R2.0	Thermoseal Wall Wrap XP		2.99	3.15
Hebel1728				90mm Bradford Gold Wall Batts R2.5	Enviroseal ProctorWrap RW		3.00	3.15
Hebel1730				90mm Bradford Gold Wall Batts R2.7	Enviroseal ProctorWrap RW	3.15	3.29	
Hebel1733				None	Polyair Performa 4.0 XHD	35mm	2.13	2.16
Hebel1763				None	Thermoseal Wall Wrap Prime		1.55	1.59
Hebel1764				90mm Bradford Gold Wall Batts R2.0	Thermoseal Wall Wrap Prime		2.67	2.83
Hebel1734				90mm Bradford Gold Wall Batts R2.0	Thermoseal Wall Wrap XP		2.99	3.15
Hebel1735	90mm Bradford Gold Wall Batts R2.5	Enviroseal ProctorWrap RW	3.00	3.15				
Hebel1737	90mm Bradford Gold Wall Batts R2.7	Enviroseal ProctorWrap RW	3.15	3.29				

**Table 2.3.5 Thermal performance of Hebel PowerPanel<sup>XL</sup> External Wall System - steel stud frame**

Hebel code	Description						Total R-value m <sup>2</sup> .K/W	
	Platerboard	Stud frame	Batts	Wall wrap	Top hat cavity	Hebel Panel	Summer	Winter
Hebel1706	10mm Gyprock Plasterboard Plus	64mm steel Stud frame	None	Polyair Performa 4.0 XHD	24mm	75mm thick Hebel PowerPanel <sup>XL</sup>	2.13	2.16
Hebel1707			70mm Bradford Soundscreen Batts R2.0	Thermoseal Wall Wrap XP			2.89	3.01
Hebel1708			70mm Bradford Soundscreen Batts R2.0	Enviroseal ProctorWrap RW			2.55	2.66
Hebel1711			None	Polyair Performa 4.0 XHD	35mm		2.13	2.16
Hebel1712			70mm Bradford Soundscreen Batts R2.0	Thermoseal Wall Wrap XP			2.89	3.01
Hebel1713			70mm Bradford Soundscreen Batts R2.0	Enviroseal ProctorWrap RW			2.55	2.66
Hebel1756		70mm steel Stud frame	None	Thermoseal Wall Wrap Prime	24mm		1.44	1.48
Hebel1757			75mm Bradford Gold Wall Batts R1.5	Thermoseal Wall Wrap Prime			2.00	2.11
Hebel1758			None	Thermoseal Wall Wrap Prime	35mm		1.44	1.48
Hebel1759			75mm Bradford Gold Wall Batts R1.5	Thermoseal Wall Wrap Prime			2.00	2.11
Hebel1765		90mm steel Stud frame	None	Thermoseal Wall Wrap Prime	24mm		1.45	1.48
Hebel1766			90mm Bradford Gold Wall Batts R2.0	Thermoseal Wall Wrap Prime			2.35	2.49
Hebel1767			None	Thermoseal Wall Wrap Prime	35mm		1.45	1.48
Hebel1768			90mm Bradford Gold Wall Batts R2.0	Thermoseal Wall Wrap Prime			2.35	2.49
Hebel1740		92mm steel Stud frame	None	Polyair Performa 4.0 XHD	24mm		2.13	2.16
Hebel1741			90mm Bradford Gold Wall Batts R2.0	Thermoseal Wall Wrap XP			2.99	3.15
Hebel1742			90mm Bradford Gold Wall Batts R2.5	Enviroseal ProctorWrap RW			3.00	3.15
Hebel1744			90mm Bradford Gold Wall Batts R2.7	Enviroseal ProctorWrap RW			3.15	3.29
Hebel1747			None	Polyair Performa 4.0 XHD	35mm		2.13	2.16
Hebel1748			90mm Bradford Gold Wall Batts R2.0	Thermoseal Wall Wrap XP			2.99	3.15
Hebel1749			90mm Bradford Gold Wall Batts R2.5	Enviroseal ProctorWrap RW			3.00	3.15
Hebel1751	90mm Bradford Gold Wall Batts R2.7		Enviroseal ProctorWrap RW	3.15		3.29		

**Table 2.3.6 Guidance on wall wrap/sarking**

Performance criteria	Guidance on wall wrap/sarking	Recommended wall wrap/ sarking	Reflective or non-reflective
Vapour barrier	Vapour barrier products are not recommended for condensation control in colder climate zones in conjunction with high insulation R Values.	Polyair Performa 4.0 XHD	Reflective double-sided
		Thermoseal Wall Wrap Prime	Reflective single-sided
		Thermoseal Wall Wrap XP	Reflective single-sided
Vapour permeable	Vapour permeable products are not recommended for use in tropical climate zones.	Enviroseal ProctorWrap RW	Non-reflective

**NOTES:**

1. Refer to NCC for state & territory variations.
2. Refer to NCC for alternative means of satisfying the required performance levels.
3. Refer to CSR Bradford product literature for design & installation requirements on wall wrap/ sarking and insulation.
4. The density of Gyprock plasterboard plus is 5.7 kg/m<sup>2</sup>.
5. Stated R-values in Tables 2.3.4 and 2.3.5 has been provided by J.Fricker calculations in report i107e, dated 03/03/2020, and report i107f dated 13/05/2020. Determinations based upon AS/NZS 4859:2018, including thermal bridging.
6. Stated R-values in Tables 2.3.4 and 2.3.5 includes 6mm skim render.
7. As per NCC 2019, where wall wrap is installed in an external wall it must be vapour permeable wall wrap for climate zones 6,7 and 8.
8. For systems where Thermoseal Wall Wrap Prime is used, timber frame size is 70mm x 35mm.

# 2.4 SOUND TRANSMISSION & INSULATION

## OVERVIEW

### Current NCC sound transmission and insulation requirements

The Hebel PowerPanel<sup>XL</sup> External Wall System is primarily used in buildings that have a domestic type of activity purpose. The NCC generally classifies these buildings into Class 1 or 10. The acoustic performance requirements for external walls in these buildings or their building elements are not currently stated in the NCC. If a building using the Hebel wall system was required to provide acoustic performance, then the performance level requirements for a building envelope and elements would be set by the relevant authorities (i.e. local councils, client specific requirements, etc).

### Design recommendations

Acoustic design is a complex science and there will be instances where a specialist acoustic consultant is required.

For walls requiring acoustic performance Hebel recommends:

1. Engaging a reputable acoustic consultant on a project-by-project basis to provide design advice and installation inspections
2. When selecting the appropriate components for the Hebel wall system, the designer or specifier must be aware that the laboratory  $R_w$  values are almost always higher than the field measured values. Therefore, allowances should be made for the lower expected field values during the selection of the system
3. Separate advice from a specialist acoustic consultant should be sought to determine the effect on acoustic performance due to any changes to the Hebel wall system, and any required modification of the installation details pertaining to the systems
4. Increasing cavity widths, using higher density or thicker insulation or plasterboard, will generally maintain or increase the acoustic performance of the Hebel wall system.

**Table 2.4.1 Acoustic performance of Hebel PowerPanel<sup>XL</sup> External Wall System - timber stud frame**

Hebel code	Description						Acoustic	
	Platerboard	Stud frame	Batts	Wall wrap	Top hat cavity	Hebel Panel	$R_w$	$R_w + C_{tr}$
Hebel1716	10mm Gyprock Plasterboard Plus	70mm timber Stud frame	None	Polyair Performa 4.0 XHD	24mm	75mm thick Hebel PowerPanel <sup>XL</sup>	38	23
Hebel1717			70mm Bradford Soundscreen Batts R2.0	Thermoseal Wall Wrap XP			40	25
Hebel1718			70mm Bradford Soundscreen Batts R2.0	Enviroseal ProctorWrap RW			40	25
Hebel1721			None	Polyair Performa 4.0 XHD	35mm		38	23
Hebel1722			70mm Bradford Soundscreen Batts R2.0	Thermoseal Wall Wrap XP			41	26
Hebel1723			70mm Bradford Soundscreen Batts R2.0	Enviroseal ProctorWrap RW			41	26
Hebel1726		90mm timber Stud frame	None	Polyair Performa 4.0 XHD	24mm	38	23	
Hebel1727			90mm Bradford Gold Wall Batts R2.0	Thermoseal Wall Wrap XP		41	26	
Hebel1728			90mm Bradford Gold Wall Batts R2.5	Enviroseal ProctorWrap RW		41	26	
Hebel1730			90mm Bradford Gold Wall Batts R2.7	Enviroseal ProctorWrap RW	41	26		
Hebel1733			None	Polyair Performa 4.0 XHD	35mm	38	23	
Hebel1734			90mm Bradford Gold Wall Batts R2.0	Thermoseal Wall Wrap XP		42	27	
Hebel1735			90mm Bradford Gold Wall Batts R2.5	Enviroseal ProctorWrap RW		42	27	
Hebel1737			90mm Bradford Gold Wall Batts R2.7	Enviroseal ProctorWrap RW		42	27	

**Table 2.4.2 Acoustic performance of Hebel PowerPanel<sup>XL</sup> External Wall System - steel stud frame**

Hebel code	Description						Acoustic	
	Platerboard	Stud frame	Batts	Wall wrap	Top hat cavity	Hebel Panel	$R_w$	$R_w + C_{tr}$
Hebel1706	10mm Gyprock Plasterboard Plus	64mm steel Stud frame	None	Polyair Performa 4.0 XHD	24mm	75mm thick Hebel PowerPanel <sup>XL</sup>	40	30
Hebel1707			70mm Bradford Soundscreen Batts R2.0	Thermoseal Wall Wrap XP			43	32
Hebel1708			70mm Bradford Soundscreen Batts R2.0	Enviroseal ProctorWrap RW			43	32
Hebel1711			None	Polyair Performa 4.0 XHD	35mm		40	31
Hebel1712			70mm Bradford Soundscreen Batts R2.0	Thermoseal Wall Wrap XP			44	33
Hebel1713			70mm Bradford Soundscreen Batts R2.0	Enviroseal ProctorWrap RW			44	33
Hebel1740		92mm steel Stud frame	None	Polyair Performa 4.0 XHD	24mm	40	31	
Hebel1741			90mm Bradford Gold Wall Batts R2.0	Thermoseal Wall Wrap XP		44	33	
Hebel1742			90mm Bradford Gold Wall Batts R2.5	Enviroseal ProctorWrap RW		44	33	
Hebel1744			90mm Bradford Gold Wall Batts R2.7	Enviroseal ProctorWrap RW	44	33		
Hebel1747			None	Polyair Performa 4.0 XHD	35mm	40	31	
Hebel1748			90mm Bradford Gold Wall Batts R2.0	Thermoseal Wall Wrap XP		44	33	
Hebel1749			90mm Bradford Gold Wall Batts R2.5	Enviroseal ProctorWrap RW		44	33	
Hebel1751			90mm Bradford Gold Wall Batts R2.7	Enviroseal ProctorWrap RW		44	33	

NOTE: Acoustic values in Tables 2.4.1 and 2.4.2 are based on acoustic assessment 20140366.34/1909A/R3/GW.

# 2.5 COATING REQUIREMENTS

Hebel PowerPanel<sup>XL</sup> panels require an appropriate external coating system and sealant detailing to ensure a water resistant and vapour permeable building envelope is achieved.

Generally, the external face of the Hebel PowerPanel<sup>XL</sup> panel is coated with a high build acrylic levelling and finishing system, applied in accordance with the recommendations of the coating manufacturer.

NOTE: The coating system is a necessary part of the Hebel PowerPanel<sup>XL</sup> external wall system to ensure the durability of the panel, validity of the applicable warranty and weathertightness of wall system is maintained. Hebel recommends the coating system to be applied as soon as possible, but within 60 days from the date of installation of Hebel PowerPanel<sup>XL</sup> panels.

Prior to application of the coating it must be ensured that:

- The PowerPanel<sup>XL</sup> panels are dry
- The panel substrate is clean from any dirt, imperfections or contamination that may prevent adhesion of the coating system onto the panel

## PERFORMANCE REQUIREMENTS

The following are items to be considered when selecting a coating system:

### Manufacturer approved:

- Hebel recommends the use of a three layer coating system. The application of a two layer coating system is also acceptable. The acrylic coating manufacturer must ensure they have evidence of suitability of their coating system over the Hebel substrate, where a two layer coating system is used.

NOTE: Where other manufacturer's coating systems are applied to Hebel external walls these coatings systems must be warranted by the coating manufacturer as appropriate for coating an AAC substrate. As a minimum coating manufacturers must verify and warrant coating system performance to the properties defined below. Coating application rates and film thickness must comply with (or exceed) the coating system manufacturer's minimum specifications.

### Surface adhesion:

- The substrate preparation and coating application should be in accordance with the coating manufacturer's specification.
- Before applying finishes in coastal areas (Refer to Section 2.1 – Durability), all PowerPanel<sup>XL</sup> panels must be thoroughly washed with fresh water to remove any salt residue. Refer to coating manufacturer for additional requirements.

### Water resistance:

- The primary objective of the coating system is to prevent liquid water ingress, yet allow water vapour transmission both in and out of the AAC substrate.
- Proven water resistance capability: Transmission: <10 grams/m<sup>2</sup>/24hr/1kPa.

### Water vapor permeability:

- For a coating to allow the 'escape' of water vapour, the coating must be vapour permeable.
- The coating system should comply with the following performance parameters:
  - Equivalent air layer thickness of water vapor diffusion  $S_d \leq 2m$ .

NOTE:

- A coating with an ( $s_d \leq 2m$ ) has less resistance to water vapour diffusion (escape) than a static 2m thick air layer.

### Compatibility:

- Ensure the coating system is compatible with the AAC substrate and construction system components, i.e:
  - Coatings may not adhere to silicone or other sealants and mastics.
  - Excessive joint adhesive or mortars smears across the panel face may require removal or specific primers.

### Durability:

- The coating must be durable and should not overly deteriorate with exposure to light (UV) and weather for the life of the coating system manufacturer's warranty.

### Coating Elasticity:

- The coating system must be able to bridge a 1mm minimum crack width.
- The coating system manufacturer can specify the minimum design specification (thickness), so that the coating is serviceable and durable.

IMPORTANT: This list of performance requirements indicates that a specific fit-for purpose coating system must be adopted, and that a simple paint coating would most likely be an inadequate coating system. Variations to the coating system must be approved and warranted by the coating system manufacturer or representative. Coating application rates and film thickness must comply with (or exceed) the coating system manufacturer's minimum specifications.

### Maintenance:

All external coating systems and sealants/caulking should be cleaned and maintained on a regular basis. Please refer to Section 2.1 - Durability.

Contact reputable coating manufacturers for their current coating maintenance guide.

## 2.6 WEATHERPROOFING

### SEALANTS

All control joints must be sealed with a suitable external grade acoustic and/or fire rated paintable sealant. All gaps between the PowerPanel<sup>XL</sup> panels and framing around windows must be caulked with an appropriate external grade sealant.

NOTE: Caulking should be applied prior to base coat with care taken not to cut the caulking during application of trowelled on render/coating.

The sealant should be installed in accordance with the sealant manufacturer's specifications.

### WALL FLASHINGS

In general, flashings shall be designed and installed in accordance with SAA-HB39 2015 – Installation Code for Metal Roofing and Wall Cladding.

NCC 2019 Volumes One and Two contain Performance Requirement (P2.4.7) relating to Condensation and Water Vapour Management and requirement states:

### CONDENSATION MANAGEMENT

Risks associated with water vapour and condensation must be managed to minimise their impact on the health of occupants.

This requirement implies that moisture levels resulting from condensation within the building must be managed such that they do not cause undue (health) impacts to occupants living within the building.

Hebel has undertaken Hygrothermal modelling in accordance with Verification Method, V2.4.7 - Verification of condensation management of NCC 2019 of the Hebel PowerPanel<sup>XL</sup> Dual Zero Boundary and External Wall Systems to justify that moisture levels satisfy the intent of Performance Requirement P2.4.7 and that omitting the installation of wall wrap in the Hebel PowerPanel<sup>XL</sup> Dual Zero Boundary and External Wall Systems will not cause a risk of condensation. (Report Ref: ff0054(03) Hygrothermal\_Assessment prepared by Fabric First dated 19th April 2020).

However, where a wall wrap is installed, particularly in climatic zones 6,7 & 8, this wall wrap must be a vapour permeable membrane.

### WALL WRAP

For Hebel PowerPanel<sup>XL</sup>, wall wrap is recommended for insulation, condensation control as well as a corrosion barrier over CCA treated timber frames.

Where wall wrap is installed in an external wall it must be of a vapour permeable type for climate zones 6, 7 and 8 as per NCC 2019 Volume Two Clause 3.8.7.2 Pliable building membrane. Wall wrap must be designed and installed in accordance with AS/NZS 4200 Part 1 – Materials and Part 2 – Installation.

### ZERO BOUNDARY WALL SYSTEM

Hebel zero boundary walls are used when access is unavailable from outside. The design and installation of the zero boundary walls should be based on the information and details provided in this guide.

On zero boundary wall applications where the external wall is up against another existing building, it is good practice to flash the top of the wall to the adjacent property to shelter the wall from external weather conditions. In cases where Hebel zero boundary wall is higher than the wall on the adjacent property, the Hebel wall cladding at the upper level is considered an external wall system and therefore should be coated as per the recommendations in this guide. For more details refer to figures 3.6.6.7 and 3.6.6.8 and Hebel technical update (Doc Ref: Boundary wall weathertightness. doc - 14 Nov 2011).

### POWERPANEL<sup>XL</sup> EXTERNAL WALL SYSTEM

The Hebel PowerPanel<sup>XL</sup> External Wall System has been tested (and results of the test assessed by AECOM) in accordance with the Verification Methods of NCC 2019, specifically the verification methods FV1 for clause FP1.4 (Volume One) and V2.2.1 for clause P2.2.2 (Volume Two).

The results of this test demonstrate the Hebel PowerPanel<sup>XL</sup> External Wall System (with adhesive applied at the panel joints) and with a suitable acrylic coating system applied over the panel will comply with the performance requirements NCC 2019 for Wind Categories N2 & N3, specifically the verification methods FV1 for clauses FP1.4 (Volume One) and V2.2.1 for clause P2.2.2 (Volume Two).

### FACE-SEALED SYSTEM

The Hebel PowerPanel<sup>XL</sup> External Wall System is considered a face-sealed system (functioning as a closed, un-drained cavity wall system, excluding weepholes) whereby the external coatings and sealant at control joints, around external window and door openings etc. form the weather tightness barrier to the external wall of the building. As such, a fit-for-purpose acrylic coating system and compatible external grade sealants, applied in accordance with manufacturers specification (and maintained in accordance with the manufacturers maintenance schedule) are important in ensuring the ongoing weather tightness performance and long term durability of the external wall system.



# 3.1 INSTALLATION OVERVIEW

## 1. COMPLETE FRAMES AND TRUSSES

### 2. DPC

- Fix DPC to bottom plate of frame
- Cover rebate completely
- Overlap DPC at corners



### 3. WALL WRAP

- Install wrap as specified by supplier ensuring that it overlaps DPC at base



### 4. TOP HATS

- Check control joint layouts for installation of discontinuous top hats
- Check the number of top hats and screws required (refer to tables on pages 6 and 7)
- Use packers and pack top hat to string line where required, screw to frame
- Check with a straight edge/spirit level that top hats are plumb
- Install top hats above and below openings



## 5. CUTTING PANELS

- Cut panels to size (refer to Appendix A notes on page 54)
- Ensure any exposed steel reinforcing has been coated with Hebel anti-corrosion paint



## 6. ADHESIVE

- Mix adhesive to a thick flowable consistency
- Apply Hebel adhesive to entire edge of panel with notched trowel
- The use of notched trowel to apply Hebel adhesive at the panel joints is essential to ensure sufficient adhesive is applied. Insufficient application of adhesive at the panel joints may result in hairline cracks at the joints.



## 7. CONTROL JOINT

- Check control joint layout
- Install backing rod into control joint at the required depth
- Apply suitable sealant to control joint
- Clean up any excess sealant ensuring it does not adhere to panel face



## 8. HEBEL POWERPANEL<sup>XL</sup> PANELS

- Corner PowerPanel<sup>XL</sup> panel to be installed first, lifting into place using panel lifters
- Fix panel to top hats (refer to tables on pages 6 and 7)
- Check panel is straight and level
- Continue installation by lifting panels into position
- Butt panel tightly to adjoining panel, screwing off as you go
- Adhesive should slightly ooze from the joint
- Once the joint adhesive is semi hard it can be cleaned up with a pallet knife, ensuring adhesive is flush with the panel face
- Patch holes and panel damage



## 9 FINISH WALL

- Trim off excess DPC
- Lightly sand and prepare surface ready for acrylic coating



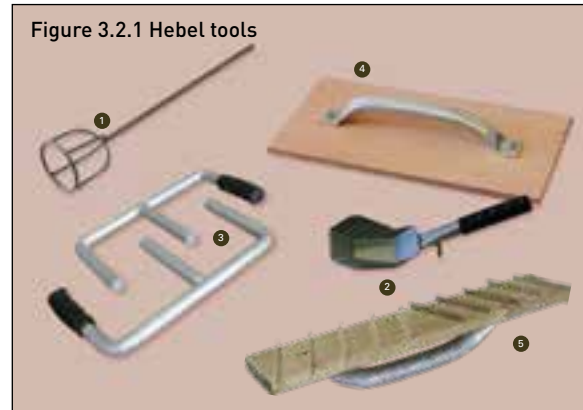
## 3.2 TOOLS AND EQUIPMENT

The basic tools required to assist in the installation of the PowerPanel<sup>XL</sup> External Wall System are shown in Figure 3.2.1. These may be purchased through a Hebel distributor and include:

- 1. Stirrer** – fitted to the electric drill, the stirrer is used to mix the Hebel Mortar, Hebel Adhesive and base levelling coat render inside the mixing bucket
- 2. Notched trowel** – the notched trowel is used to apply the Hebel Adhesive to the Hebel surfaces. The width of the trowel must match the panel thickness to ensure the adhesive is applied with full and even coverage
- 3. Panel lifters** – used to carry the panels around the work site
- 4. Sand float** – used to remove excess Hebel Adhesive and smooth joints between panels
- 5. Levelling plane** – used to even out inconsistencies in the Hebel panels.

Extra equipment will also be required and includes the following:

- Power drill (clutch driven)
- Power saw with metal or diamond tipped cutting blades
- Dust extraction system
- Sockets for screws
- Personal Protective Equipment (PPE) such as goggles, ear muffs/plugs and face mask used when site cutting the PowerPanel<sup>XL</sup> panels.



## 3.3 INSTALLATION OF SERVICES

The installation of services in the building are the same as the methods currently being used throughout the industry.

Services should be installed through the frame to avoid interfering with top hat layout, but if they are to be fixed on the outside of the frame, they should only run horizontally



Figure 3.3.1 Installed piping services prior to the installation of Hebel PowerPanel<sup>XL</sup>

parallel to the top hats – typically 300mm up from the bottom plate.

Penetrations through the PowerPanel<sup>XL</sup> panel for services should be neatly filled and the joint sealed.



Figure 3.3.2 Neat finishes of installed services

## 3.4 EXTERNAL ALUMINIUM RENDER BEAD (OPTIONAL)



Figure 3.4.1 Neat finish of horizontal joints

The external aluminium render bead can be used as an option at horizontal joints to provide neat and consistent finish joints. After installation of the PowerPanel<sup>XL</sup> panels, the render bead is applied and hold onto place by using Hebel adhesive. Suitable external grade sealant is to be applied at the joint before rendering.

### NOTES:

The external aluminium render bead is not recommended in the following conditions:

- Within 100m of breaking surf.
- Within 100m of heavy industrial emissions.
- Areas exposed to prevailing winds containing salt of heavy industrial emissions.
- Where continuous or cyclical moisture is present (eg retaining walls, planter boxes, garden beds)
- Environments where bore water or soils contain high chloride content.

# 3.5 CONSTRUCTION DETAILS – OVERVIEW

Table 3.5.1 CONSTRUCTION DETAILS

Single storey construction details	Isometric view detail panel supported at base	Figure 3.6.1.1	Page 28
	Isometric view detail panel suspended	Figure 3.6.1.2	Page 28
	Hip roof elevation	Figure 3.6.1.3	Page 29
	Gable end elevation	Figure 3.6.1.4	Page 29
	Typical section detail	Figure 3.6.1.5	Page 30
	High wall section detail (3900mm max.)	Figure 3.6.1.6	Page 30
Two storey construction details	Isometric view detail	Figure 3.6.2.1	Page 31
	Hip roof elevation	Figure 3.6.2.2	Page 32
	Gable end elevation	Figure 3.6.2.3	Page 32
	Typical timber frame section using joists with >1% shrinkage	Figure 3.6.2.4	Page 33
	Steel frame section or engineered joists with ≤1% shrinkage	Figure 3.6.2.5	Page 33
	Hebel external wall cladding detail extending above first floor	Figure 3.6.2.6	Page 34
Two storey addition details	Isometric view detail	Figure 3.6.3.1	Page 34
	Typical section with brick veneer below	Figure 3.6.3.2	Page 35
	Typical section with double brick below	Figure 3.6.3.3	Page 35
Fixing & installation details	Hebel PowerPanel <sup>XL</sup> External Wall System fixing detail	Figure 3.6.4.1	Page 36
	Hebel PowerPanel <sup>XL</sup> zero Boundary Wall System fixing detail	Figure 3.6.4.2	Page 36
	Screw layout drawing	Figure 3.6.4.3	Page 36
	PowerPanel <sup>XL</sup> zero Boundary Wall System	Figure 3.6.4.4	Page 36
Footing junction details	Junction to shallow concrete footing	Figure 3.6.5.1	Page 37
	Junction to deep concrete edge beam	Figure 3.6.5.2	Page 37
	Junction to masonry earth retaining wall	Figure 3.6.5.3	Page 37
	Junction to masonry dwarf wall	Figure 3.6.5.4	Page 37
	Junction to existing piers/stumps	Figure 3.6.5.5	Page 38
	Base detail suspended floor - pier connection	Figure 3.6.5.6	Page 38
	Junction to shallow concrete edge beam	Figure 3.6.5.7	Page 39
	Junction to steel angle	Figure 3.6.5.8	Page 39
	Junction to Hebel below finish ground	Figure 3.6.5.9	Page 39
	Junction to Hebel below concrete pavement slab	Figure 3.6.5.10	Page 39
Wall junction details & sections	Typical roof eaves detail – Option 1	Figure 3.6.6.1	Page 40
	Typical roof eaves detail – Option 2	Figure 3.6.6.2	Page 40
	Roof to wall junction detail - Option 1	Figure 3.6.6.3	Page 40
	Roof to wall junction detail - Option 2	Figure 3.6.6.4	Page 40
	Typical roof eaves detail for zero boundary wall systems	Figure 3.6.6.5	Page 40
	Balcony detail	Figure 3.6.6.6	Page 40
	Zero boundary wall detail to Hebel PowerPanel <sup>XL</sup> external wall system	Figure 3.6.6.7	Page 41
	Zero boundary wall detail to brick veneer	Figure 3.6.6.8	Page 41

Wall junction details & sections	Parapet capping	Figure 3.6.6.9	Page 41
	Hebel to pitched roof junction	Figure 3.6.6.10	Page 41
	Gable end wall detail	Figure 3.6.6.11	Page 42
	Gable end wall detail – lintel panel over window	Figure 3.6.6.12	Page 42
	Beam penetration detail	Figure 3.6.6.13	Page 42
	Column detail (glued and screwed)	Figure 3.6.6.14	Page 42
Control joint details	Internal corner	Figure 3.6.7.1	Page 43
	External corner	Figure 3.6.7.2	Page 43
	Typical detail for control joints positioned on corner	Figure 3.6.7.3	Page 44
	Typical detail for control joints positioned away from a corner	Figure 3.6.7.4	Page 44
	Typical horizontal control joint – engineered timber or steel frame	Figure 3.6.7.5	Page 45
	Horizontal control joint – cavity brickwork to Hebel PowerPanel <sup>XL</sup>	Figure 3.6.7.6	Page 45
	Horizontal control joint – Brick veneer to Hebel PowerPanel <sup>XL</sup> - Option 1	Figure 3.6.7.7	Page 45
	Horizontal control joint – Brick veneer to Hebel PowerPanel <sup>XL</sup> - Option 2	Figure 3.6.7.8	Page 45
	Typical vertical control joint	Figure 3.6.7.9	Page 45
	Typical vertical control joint with double studs	Figure 3.6.7.10	Page 45
	Control joint – aligned top hats on double stud	Figure 3.6.7.11	Page 46
	Control joint – discontinuous top hats on a single stud	Figure 3.6.7.12	Page 46
	Typical window control joint detail – lintel over	Figure 3.6.7.13	Page 46
Door & window details	Typical window sill detail – aluminium window frame – Option 1	Figure 3.6.8.1	Page 47
	Typical window sill detail – aluminium window frame – Option 2	Figure 3.6.8.2	Page 47
	Typical window sill detail – aluminium window frame – Option 3	Figure 3.6.8.3	Page 47
	Header detail	Figure 3.6.8.4	Page 47
	Garage head detail	Figure 3.6.8.5	Page 47
	Garage door – jamb detail – Option 1	Figure 3.6.8.6	Page 47
	Garage door – jamb detail – Option 2	Figure 3.6.8.7	Page 47
	Sliding door sill detail – Concrete sill < 270mm	Figure 3.6.8.8	Page 48
	Sliding door sill detail – PowerPanel <sup>XL</sup> sill > 270mm	Figure 3.6.8.9	Page 48
Miscellaneous detail	Panel layout drawing – Plan view	Figure 3.6.9.1	Page 49

**Project specific requirements: please contact CSR Hebel for advice on any project specific designs not covered in this Design and Installation Guide.**

# 3.6 CONSTRUCTION DETAILS

## 3.6.1 SINGLE STOREY CONSTRUCTION DETAILS

Figure 3.6.1.1 Single storey construction – isometric view detail panel supported at base

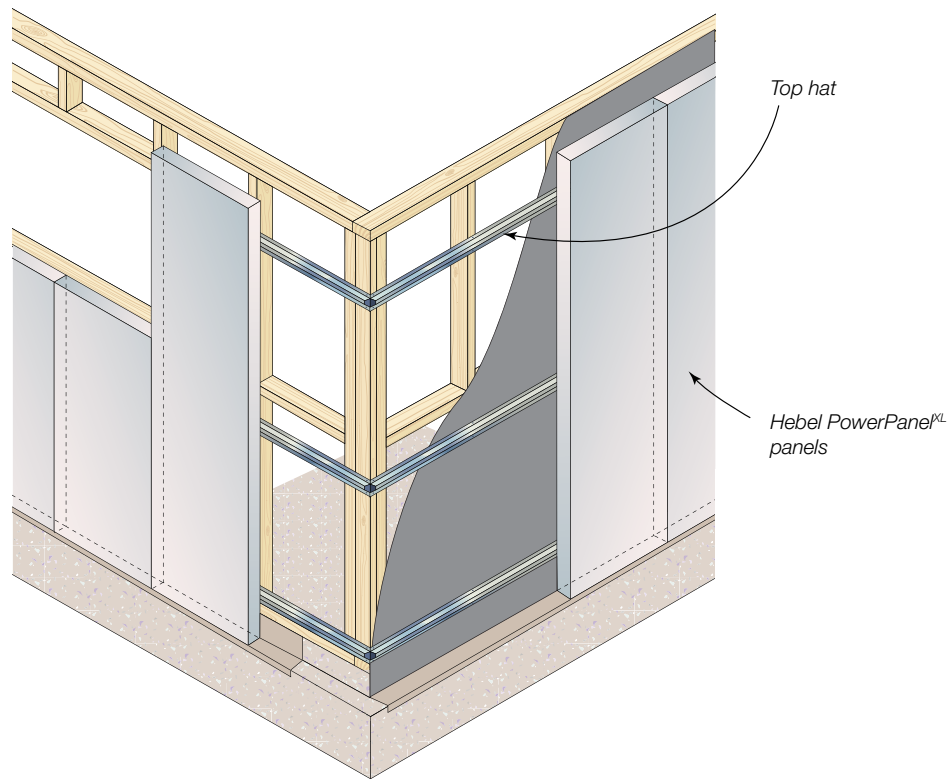
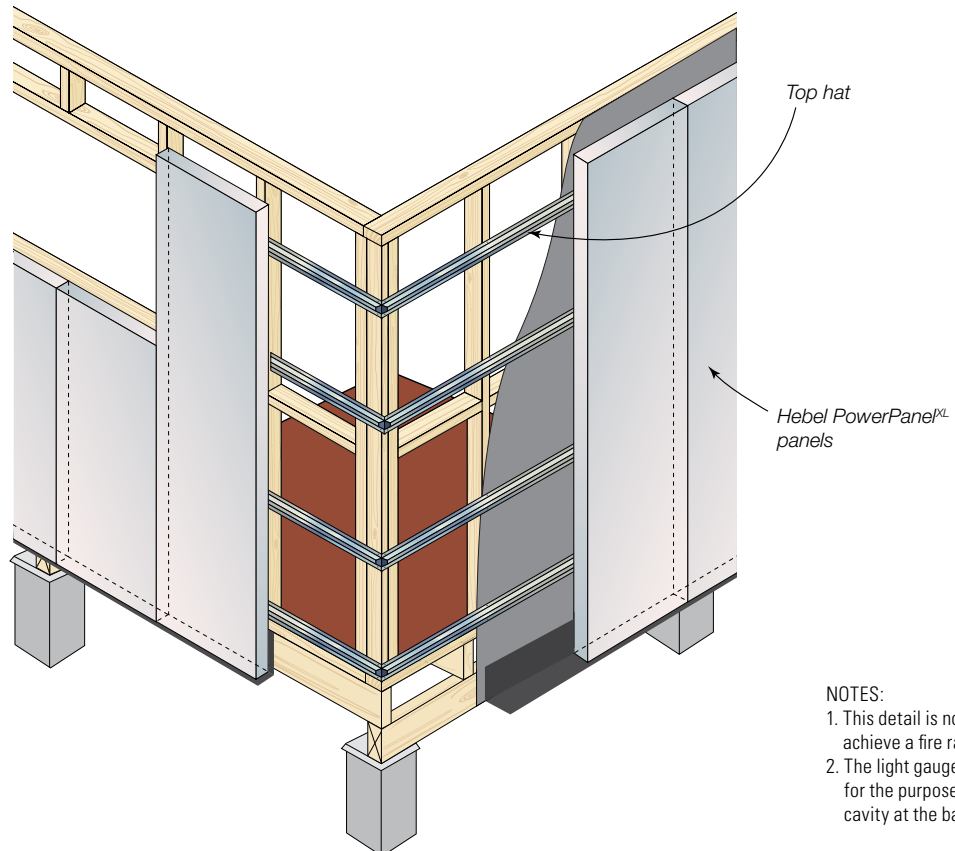


Figure 3.6.1.2 Single storey construction – isometric view detail panel suspended



- NOTES:
1. This detail is not considered to achieve a fire rating level.
  2. The light gauge steel angle is for the purpose of closing the cavity at the base of the wall.

Figure 3.6.1.3 Single storey construction – hip roof elevation

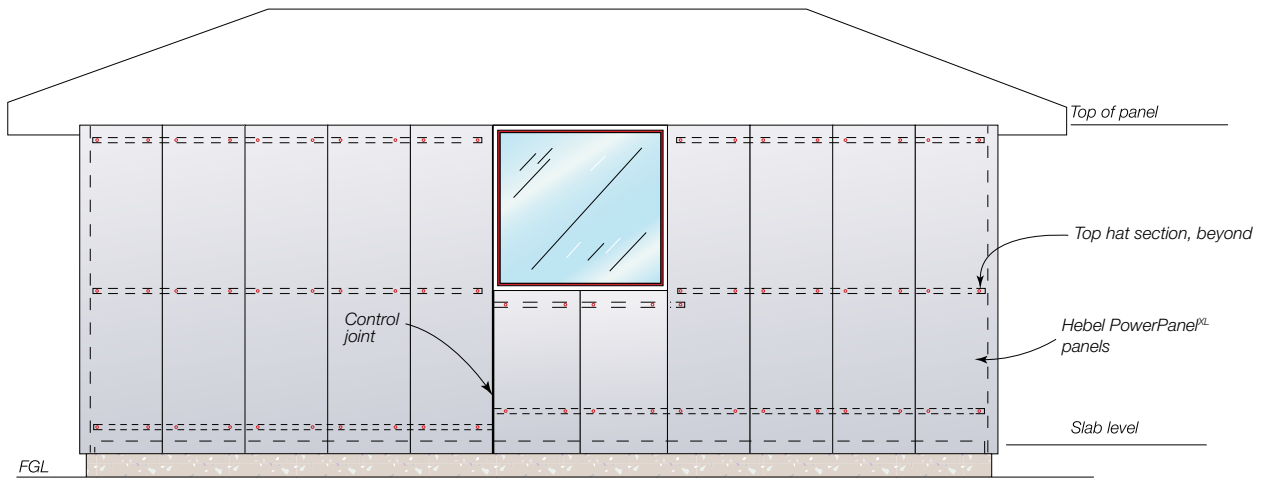
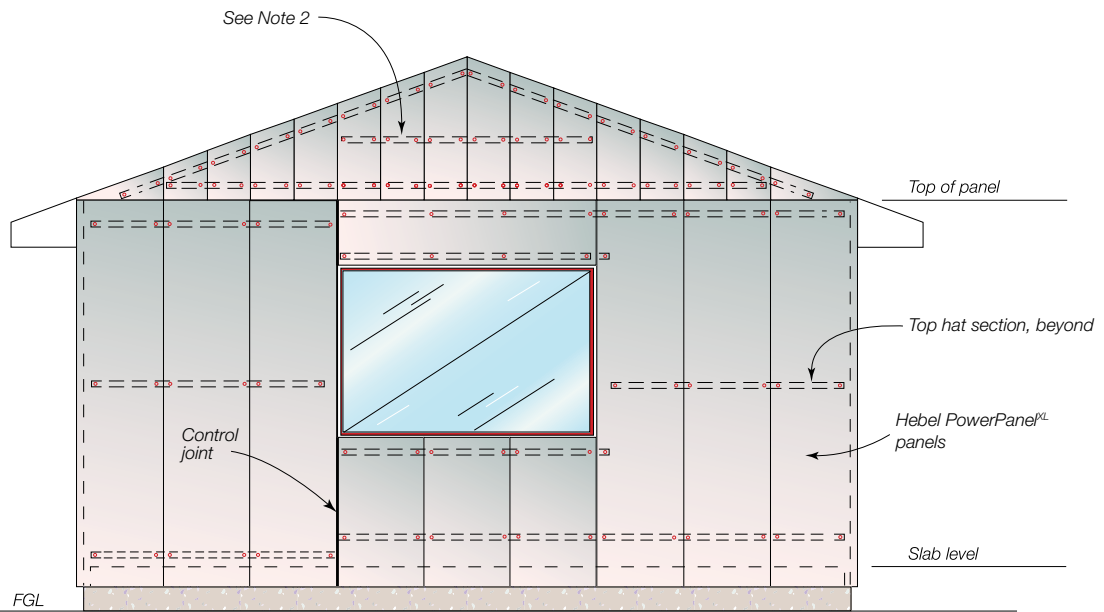


Figure 3.6.1.4 Single storey construction – gable end elevation



NOTES:

1. Number of top hats and top hat spacing to be confirmed by the building designer.
2. Additional top hats may be required, for suspended panels. Refer to Table 1.2.4 of this guide.
3. These details have not shown the set-out of top hats to accommodate control joint locations. This is the responsibility of the building designer.
4. Horizontally installed Hebel PowerPanel<sup>XL</sup> panels above openings can be installed with top hat sections running horizontally or vertically. A minimum 3 top hat sections will be required for vertically installed top hats. All top hats to be spaced evenly, with the two outer top hats installed 250mm (maximum) from the end of the PowerPanel<sup>XL</sup>. Refer to design tables 1.2.1 and 1.2.2.



### 3.6.2 TWO STOREY CONSTRUCTION DETAILS

Figure 3.6.2.1 Two storey construction – isometric view detail

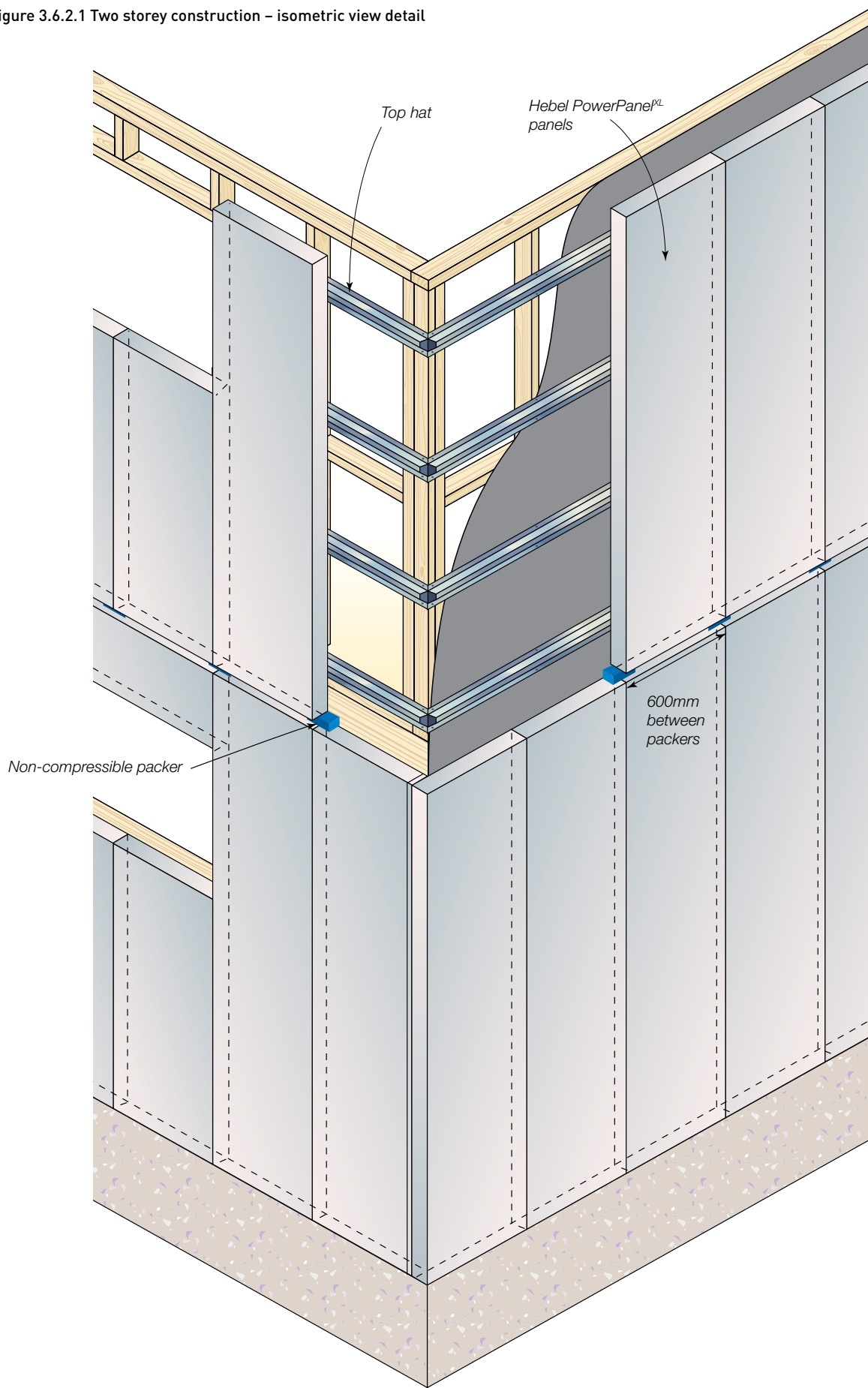




Figure 3.6.2.2 Two storey construction – hip roof elevation

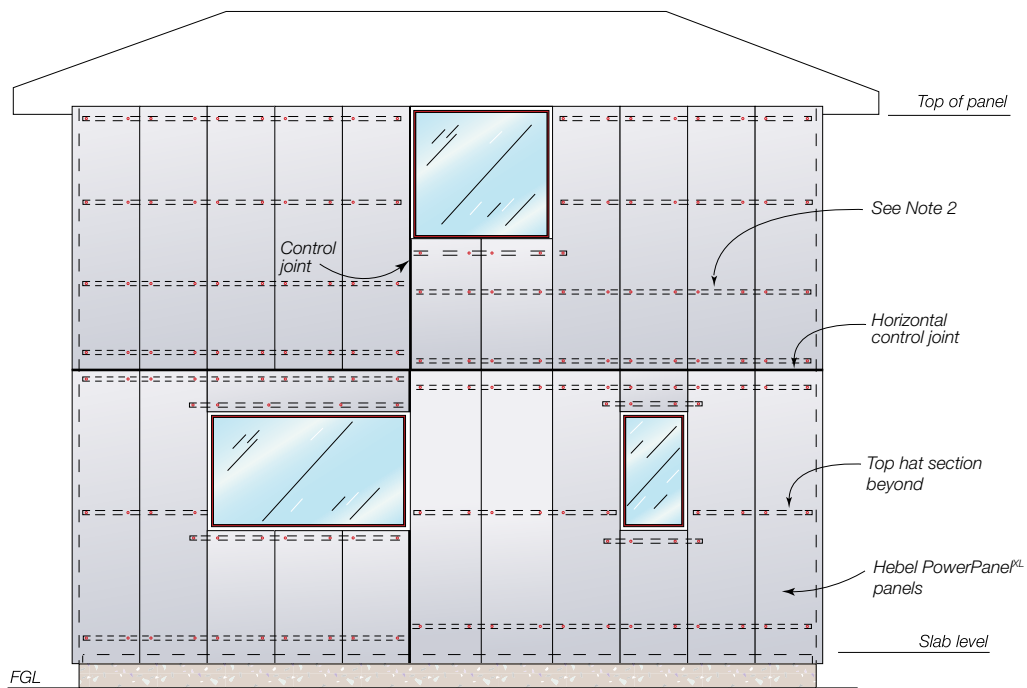
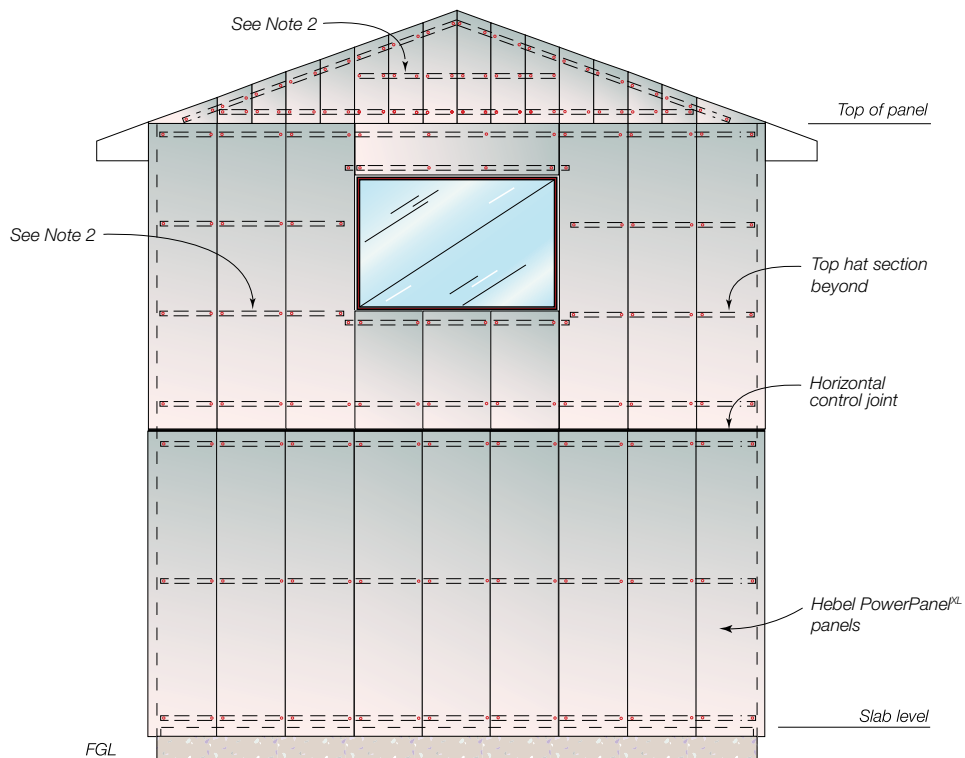


Figure 3.6.2.3 Two storey construction – gable end elevation



NOTES:

1. Number of top hats and top hat spacing to be confirmed by the building designer.
2. Additional top hats may be required, for suspended panels. Refer to Table 1.2.4 of this guide.
3. These details have not shown set-out of top hats to accommodate control joint locations. This is the responsibility of the building designer.
4. Frame design of lower floor to allow for extra load on wall from upper floor PowerPanelXL panels.
5. Minimum four horizontal top hats required for upper floor PowerPanelXL panels.
6. Horizontally installed Hebel PowerPanelXL panels above openings can be installed with top hat sections running horizontally or vertically. A minimum 3 top hat sections will be required for vertically installed top hats. All top hats to be spaced evenly, with the two outer top hats installed 250mm (maximum) from the end of the PowerPanelXL. Refer to design tables 1.2.1 and 1.2.2.

Figure 3.6.2.4 Two storey construction – typical timber frame section using joists with >1% shrinkage

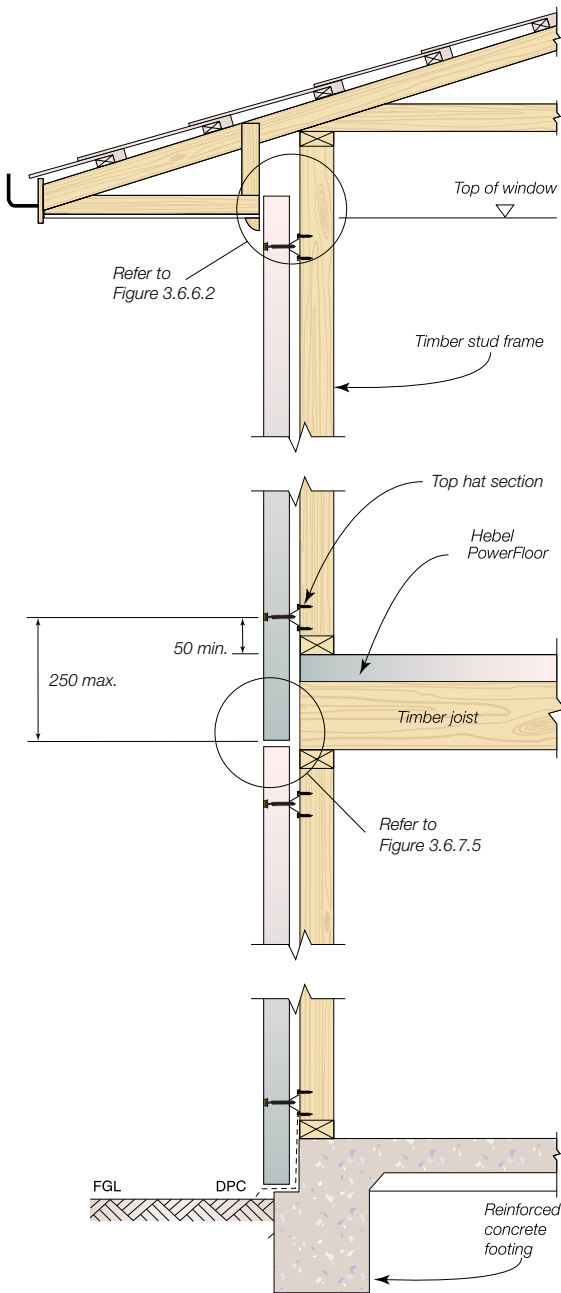
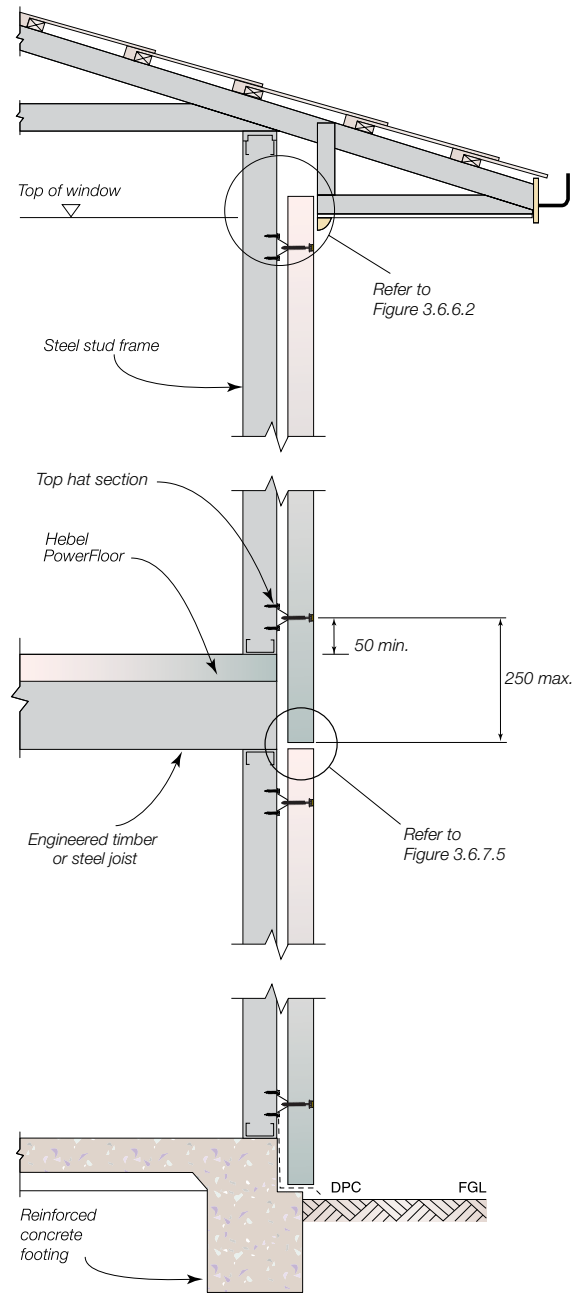


Figure 3.6.2.5 two storey construction – steel frame section or engineered joists with  $\leq 1\%$  shrinkage

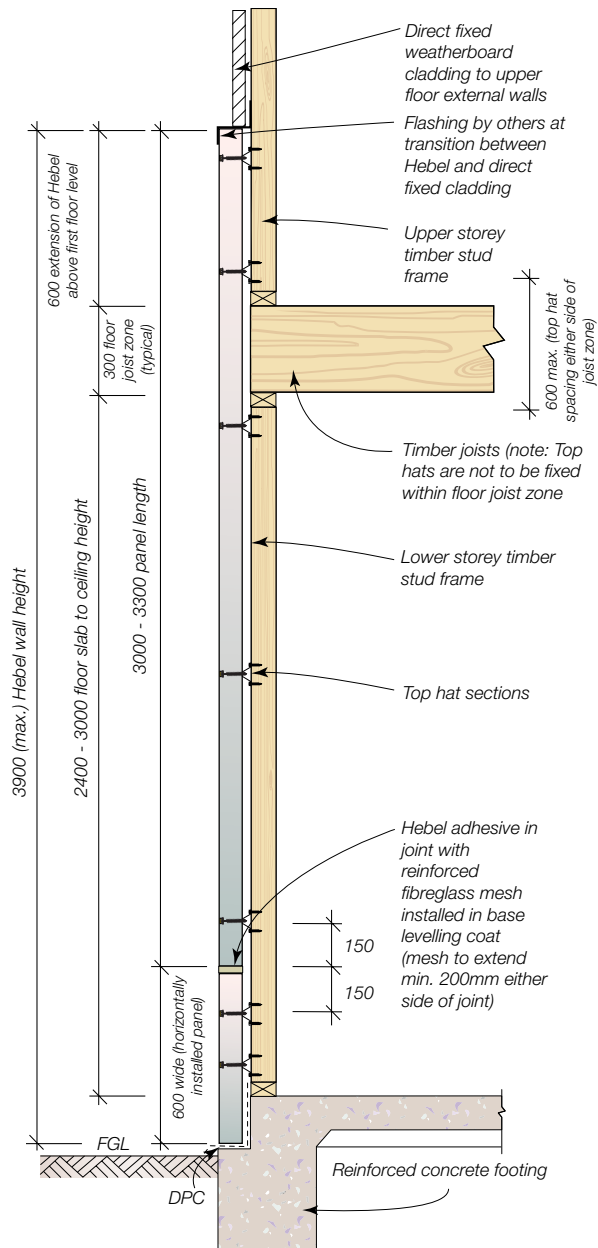


NOTES:

1. Lower storey Hebel PowerPanel<sup>XL</sup> Panels are supported at the base on concrete slab edge.

### 3.6.3 TWO STOREY ADDITION DETAILS

Figure 3.6.2.6 Hebel external wall cladding detail extending above first floor



Note: 600mm wide (horizontally installed panel) can be installed above full length panel provided Hebel adhesive in joint with reinforced fibreglass mesh is installed in base levelling coat (mesh to extend min. 200mm either side of joint)

Figure 3.6.3.1 Two storey addition – isometric view detail

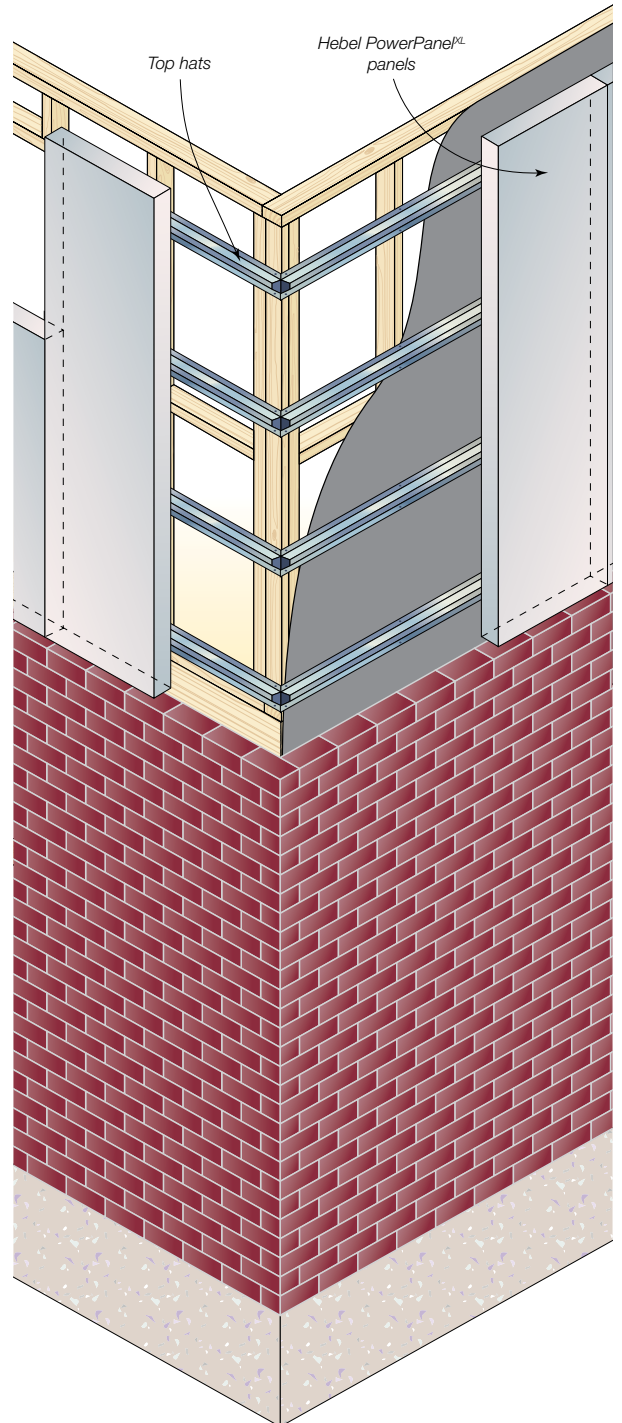


Figure 3.6.3.2 Two storey additions – typical section with brick veneer below

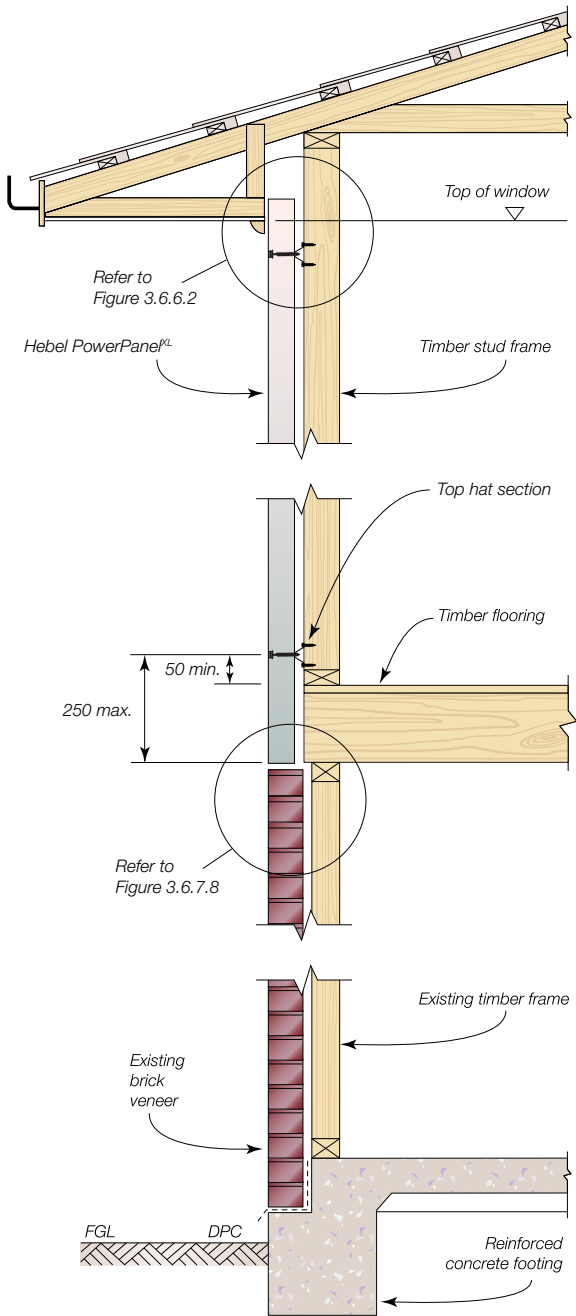
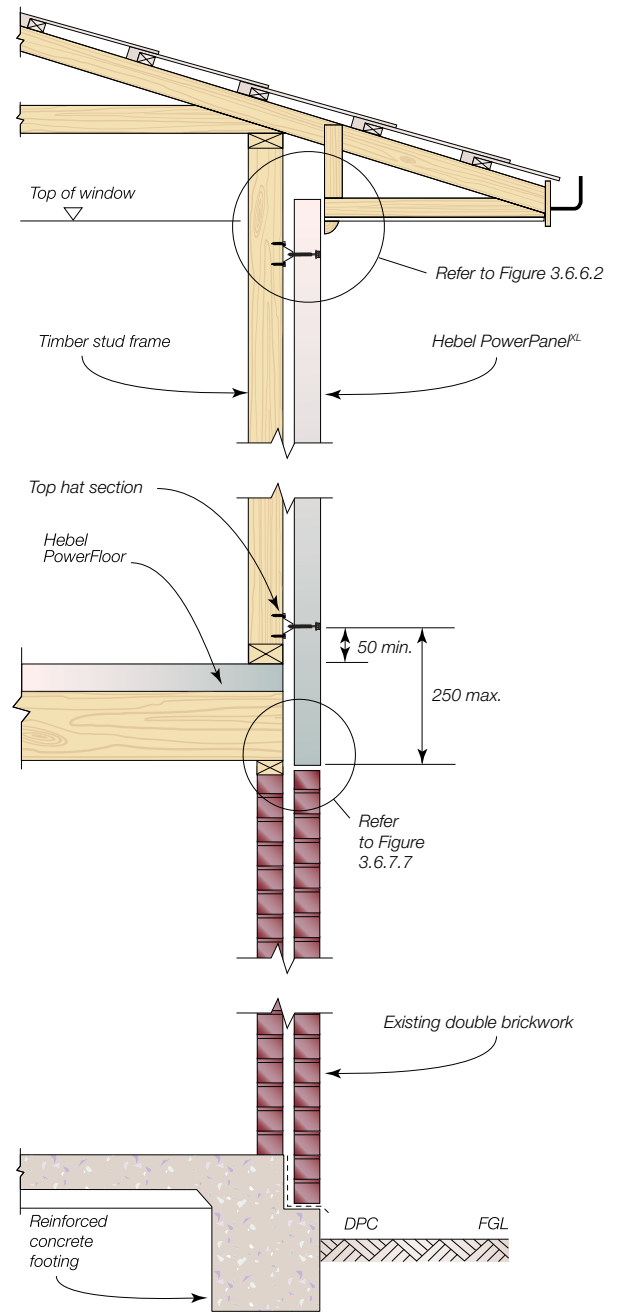


Figure 3.6.3.3 Two storey additions – typical section with double brick below

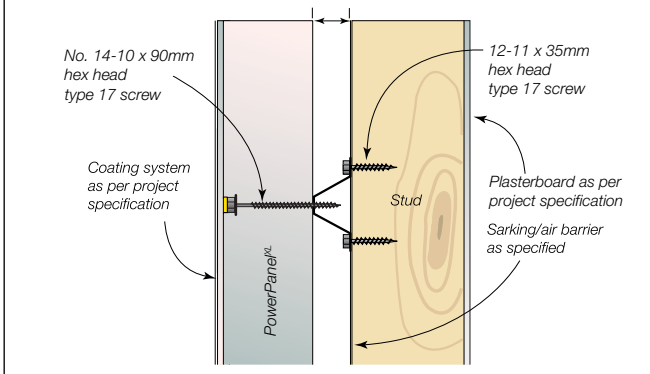


NOTES:

1. Minimum 4 top hats required for panels that are suspended off the frame. Refer to Table 1.2.4 of this guide.

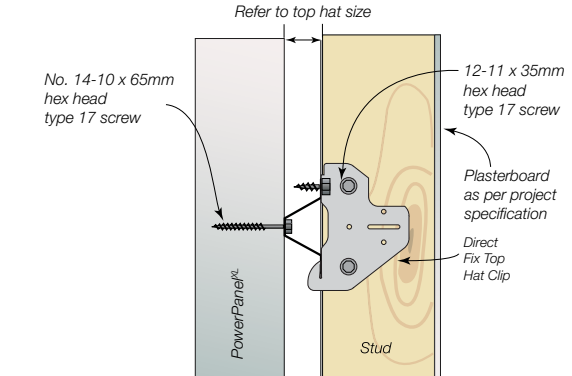
### 3.6.4 FIXING & INSTALLATION DETAILS

**Figure 3.6.4.1 Hebel PowerPanel<sup>XL</sup> External Wall System fixing detail (Achieves FRL 90/90/90 when installed as part of the wall system. See Section 2.2)**



**NOTE:**  
When positioning the stud frames allow 5-7mm extra cavity width for the sheet bracing between top hat and timber stud.

**Figure 3.6.4.2 Hebel PowerPanel<sup>XL</sup> Zero Boundary Wall System fixing detail (Achieves FRL 90/90/90 when installed as part of the wall system. See Section 2.2)**



**IMPORTANT:** Top hat clip is fixed on the left hand side of the stud (when looking from inside to the outside of the building) except at the last stud, only, when the clip may be installed upside down.

Installing the clip upside down i.e. where the screw fixing from the clip to the top hat is at the bottom flange of the top hat, will be acceptable provided that:

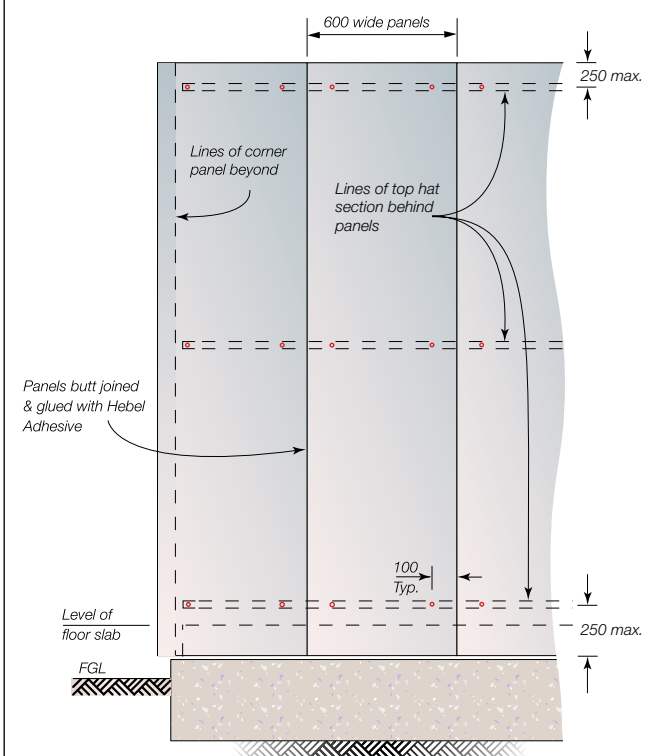
- A: The upside down clip is fixed on the right hand side of the stud (when looking from the inside to the outside of the building)
- B: The upside down clip installation is to the last stud of a wall run (only), such that the spacing between the last and second last studs is no greater than 600mm,
- C: The top hat is continuous in this region for a minimum of two spans i.e. top hat extends across two stud spacings,
- D: In all other locations, clips are to be installed to the left hand side of the stud with the screw fixing to the top side of the clip i.e. into the top flange of the horizontal top hat.

**Outside Building**

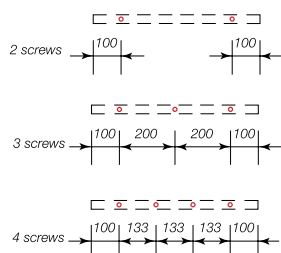


**Inside Building**

**Figure 3.6.4.3 Screw layout drawing**

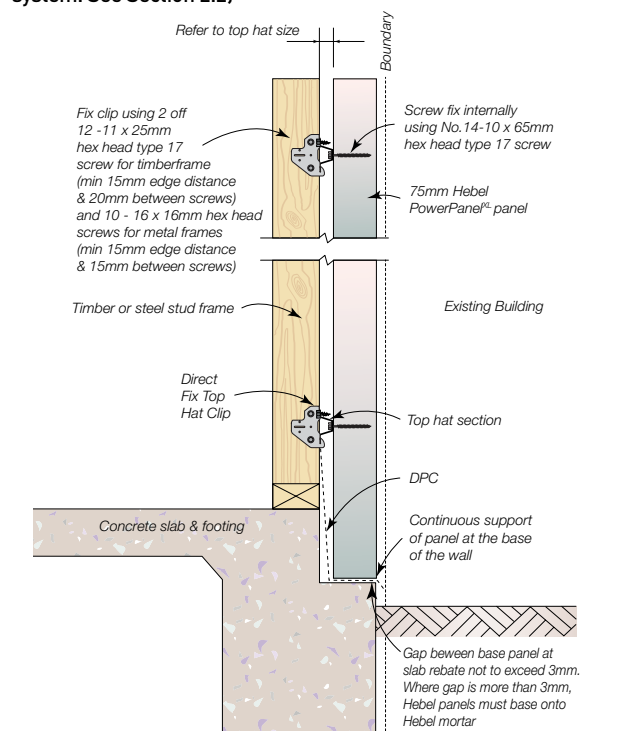


PowerPanel<sup>XL</sup> panel setout – elevation view



Screw layout

**Figure 3.6.4.4 Hebel PowerPanel<sup>XL</sup> zero Boundary Wall System (Achieves FRL 90/90/90 when installed as part of the wall system. See Section 2.2)**



### 3.6.5 FOOTING JUNCTION DETAILS

Figure 3.6.5.1 Junction to shallow concrete footing

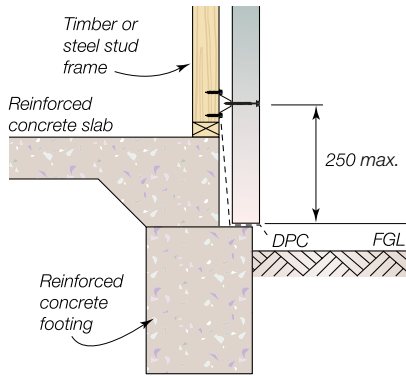


Figure 3.6.5.2 Junction to deep concrete edge beam

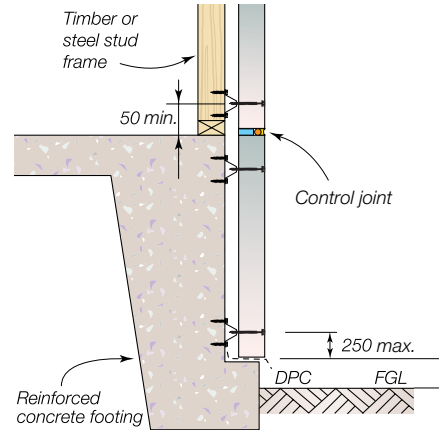


Figure 3.6.5.3 Junction to masonry earth retaining wall

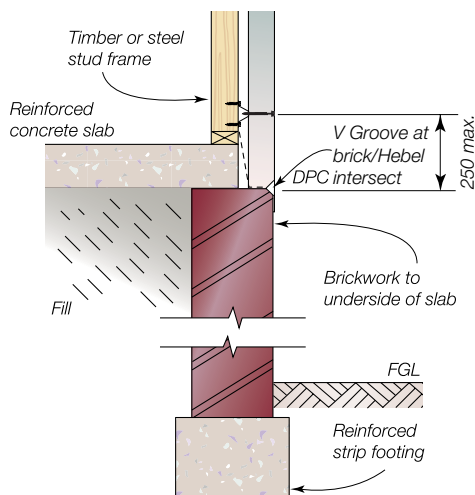
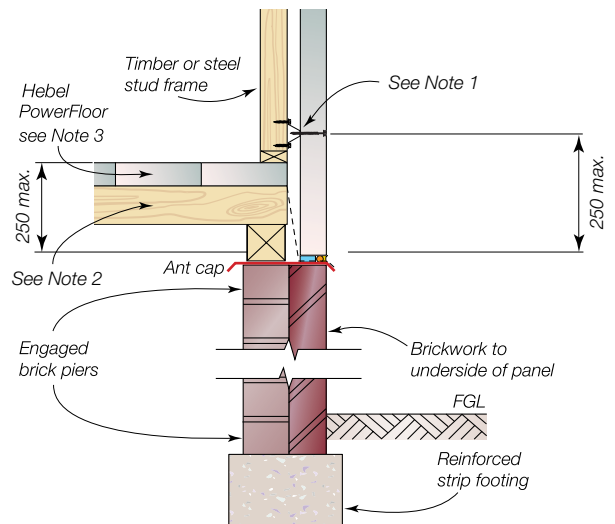


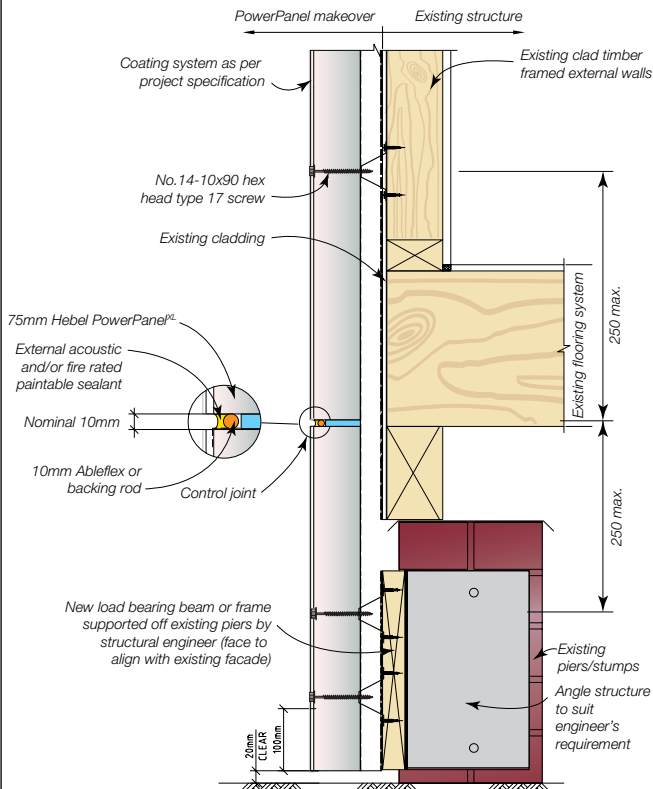
Figure 3.6.5.4 Junction to masonry dwarf wall



NOTES:

1. Do not fix top hat to floor joists.
2. If non-shrink floor joists are used, gap may be reduced or eliminated. Seek further technical advice from the framing manufacturer.
3. Refer to CSR Hebel for Hebel PowerFloor details.
4. Refer AS 3660 for termite protection.
5. When fixing top hats to concrete, contact the fixing manufacturer for details.
6. Refer to Table 1.2.6 for top hat requirements for deep concrete edge beam applications.

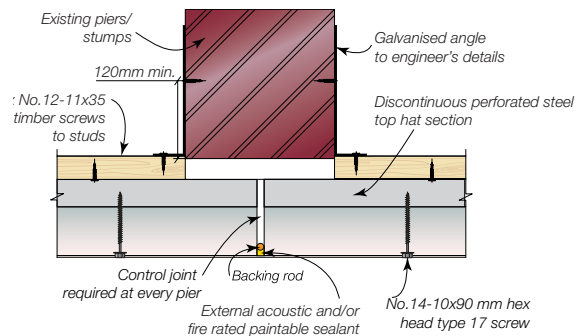
**Figure 3.6.5.5 Junction to existing piers/stumps**



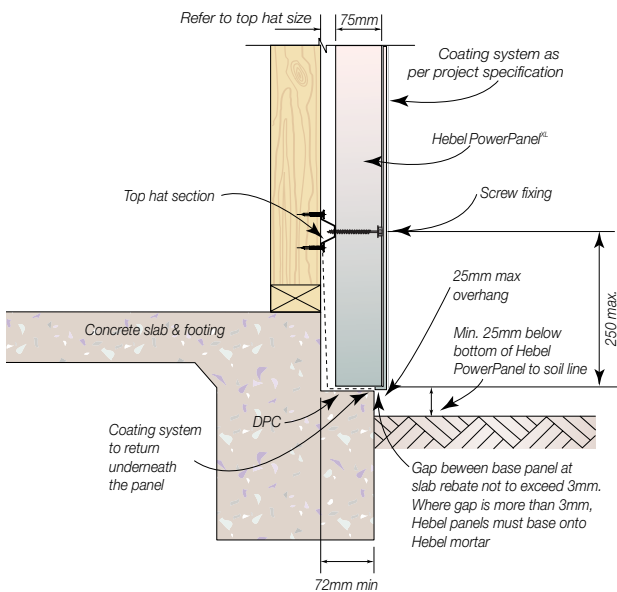
**NOTES:**

1. Refer to Tables 1.2.3 to 1.2.5 for top hat requirement for suspended applications
2. This detail is not considered to achieve a fire rating level
3. This slab edge detail does not comply with the termite visible inspection zone requirements. Alternate termite management systems must be used when selection this detail. It is the responsibility of the builder to provide a suitable physical or chemical barrier in accordance with AS 3660.

**Figure 3.6.5.6 Base detail suspended floor – pier connection**



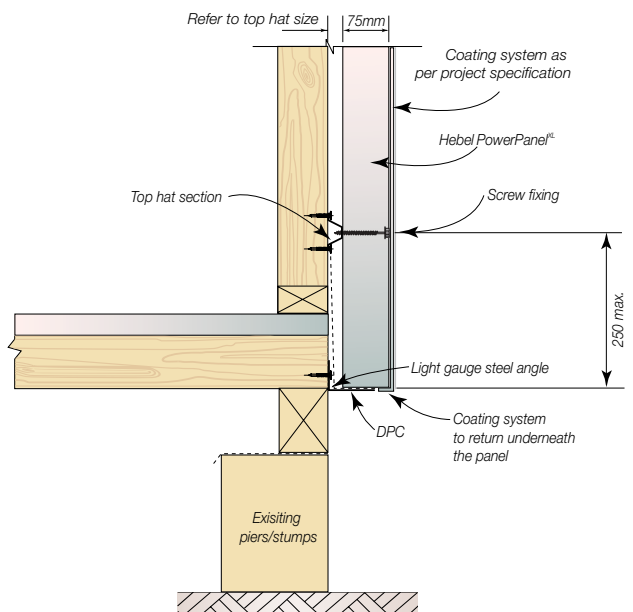
**Figure 3.6.5.7 Junction to shallow concrete edge beam (Achieves FRL 180/180/180 when installed as part of the wall system. See Section 2.2)**



**NOTES:**

1. All garden beds and /or finished soil line must remain a minimum of 25mm below the bottom of the finished rendered wall.
2. This slab edge detail does not comply with the termite visible inspection zone requirements. Alternate termite management systems must be used when selection this detail. It is the responsibility of the builder to provide a suitable physical or chemical barrier in accordance with AS 3660.

**Figure 3.6.5.8 Junction to steel angle**



**NOTES:**

1. This detail is not considered to achieve a fire rating level.
2. The light gauge steel angle is for the purpose of closing the cavity at the base of the wall.

Figure 3.6.5.9 Junction to Hebel below finish ground

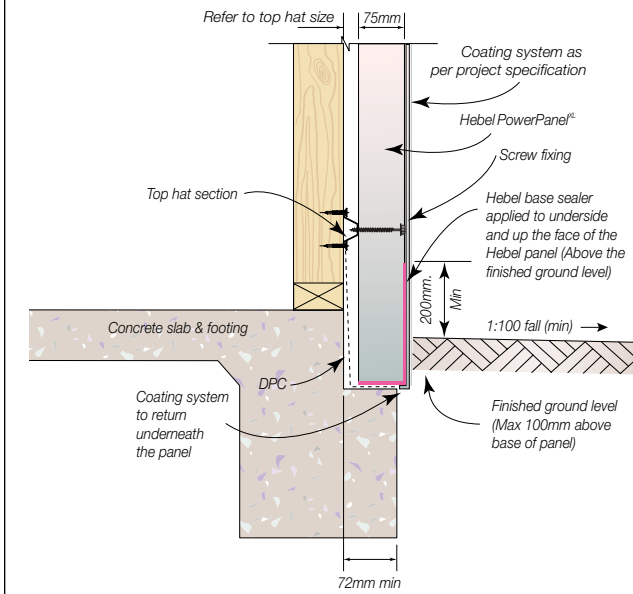
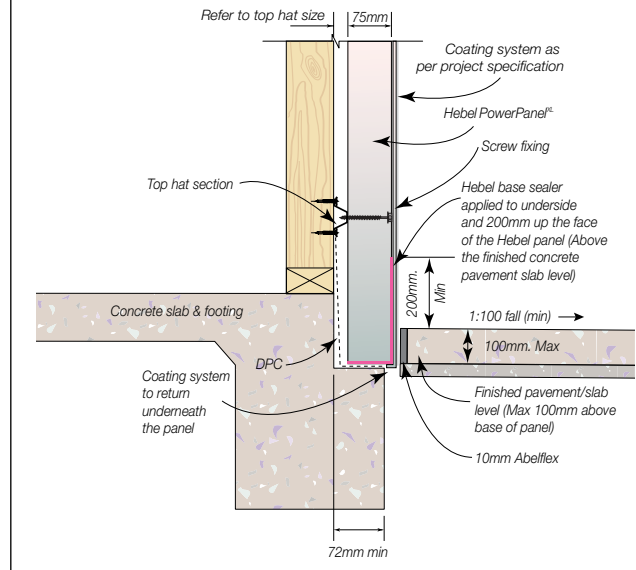


Figure 3.6.5.10 Junction to Hebel below concrete pavement slab



NOTES:

1. This slab edge detail does not comply with the termite visible inspection zone requirements. It is the responsibility of the builder to ensure chemical barrier in accordance with AS3660 is installed or other suitable termite protection system is adopted.
2. Hebel PowerPanel base must be coated with Hebel Base Sealer prior to installation.
3. Hebel Base Sealer to be applied min. 200mm above finished level.



### 3.6.6 WALL JUNCTION DETAILS & SECTIONS

Figure 3.6.6.1 Typical roof eaves detail - Option 1

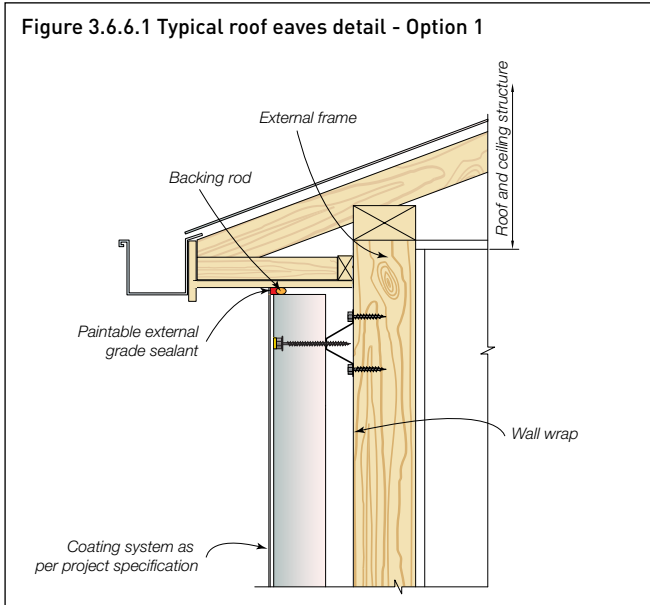


Figure 3.6.6.2 Typical roof eaves detail - Option 2

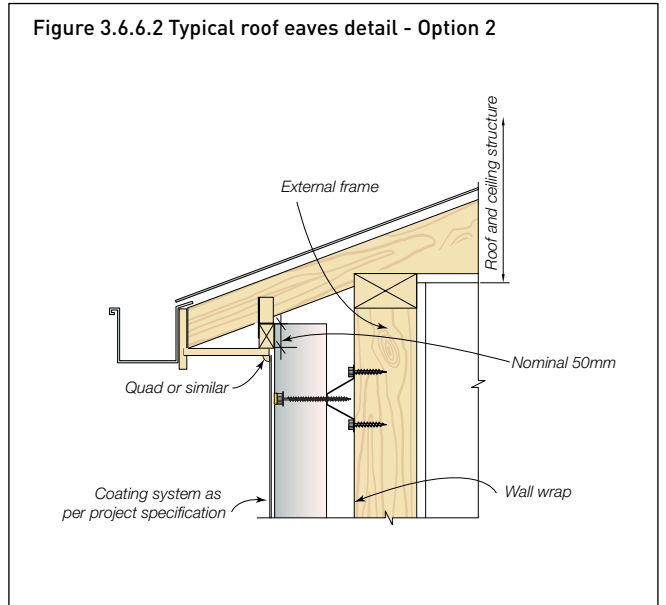


Figure 3.6.6.3 Roof to wall junction detail - Option 1

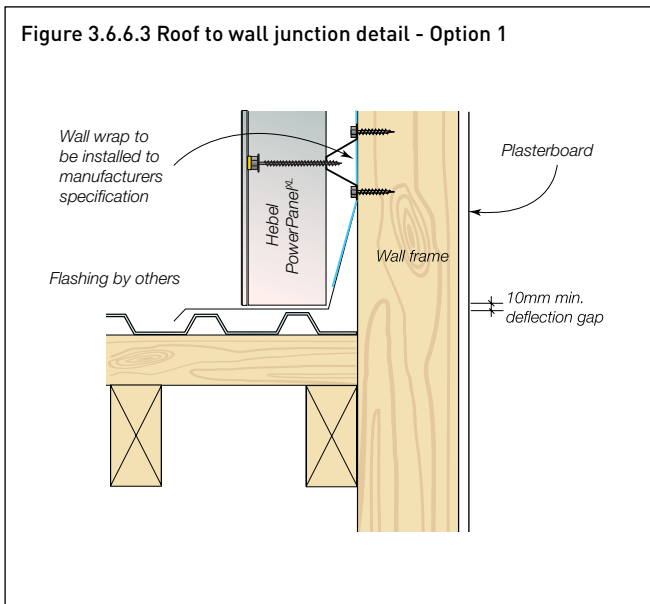


Figure 3.6.6.4 Roof to wall junction detail - Option 2

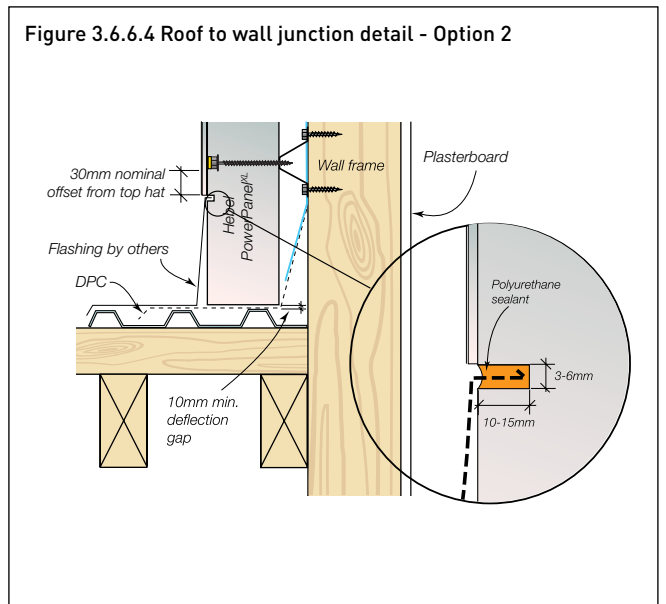


Figure 3.6.6.5 Typical roof eaves detail for Zero boundary wall systems (Achieves FRL 90/90/90 when installed as part of the wall system. See Section 2.2)

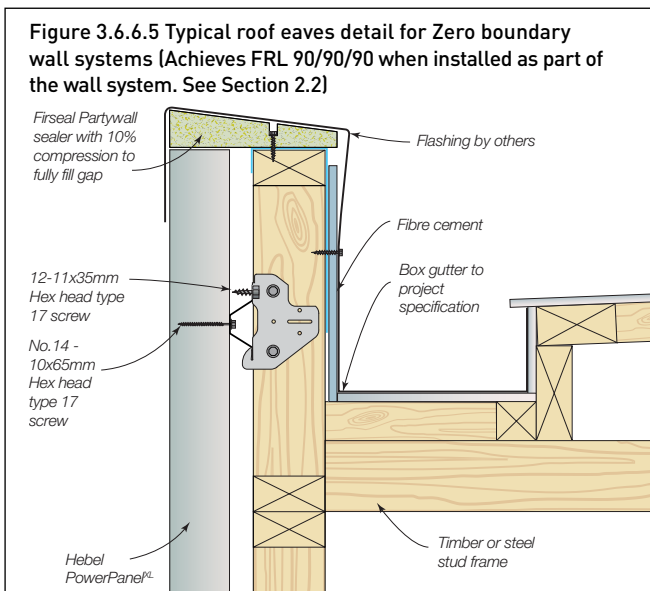
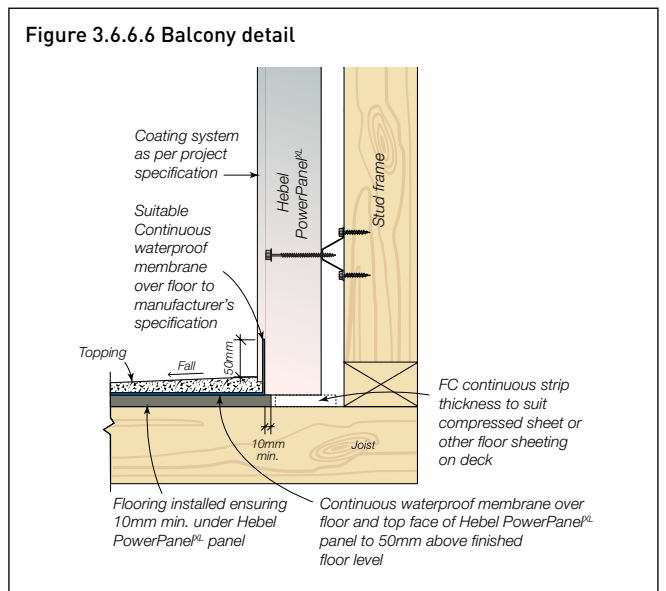
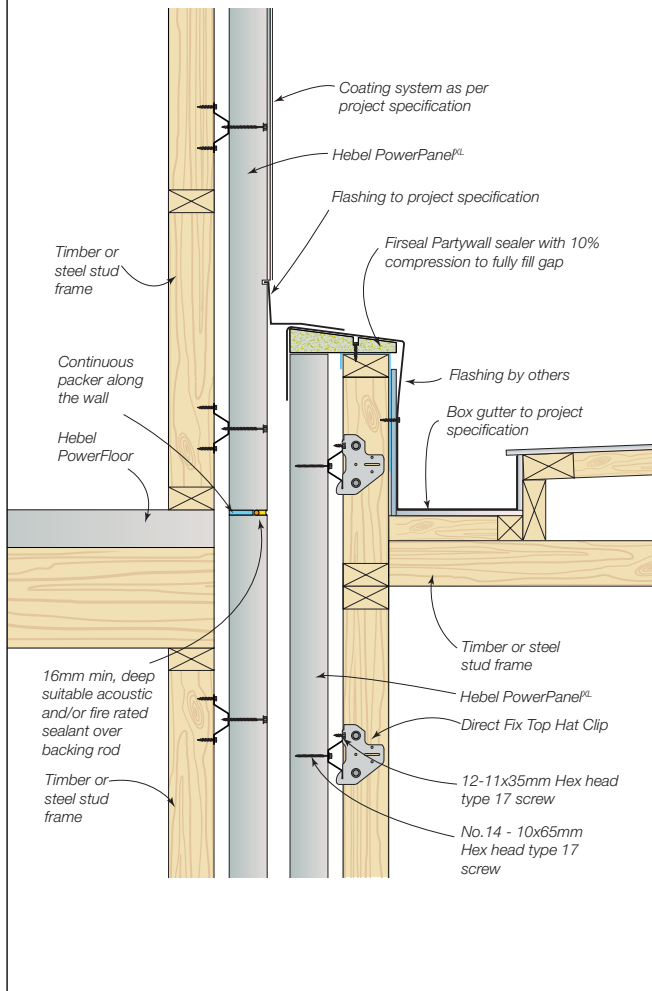


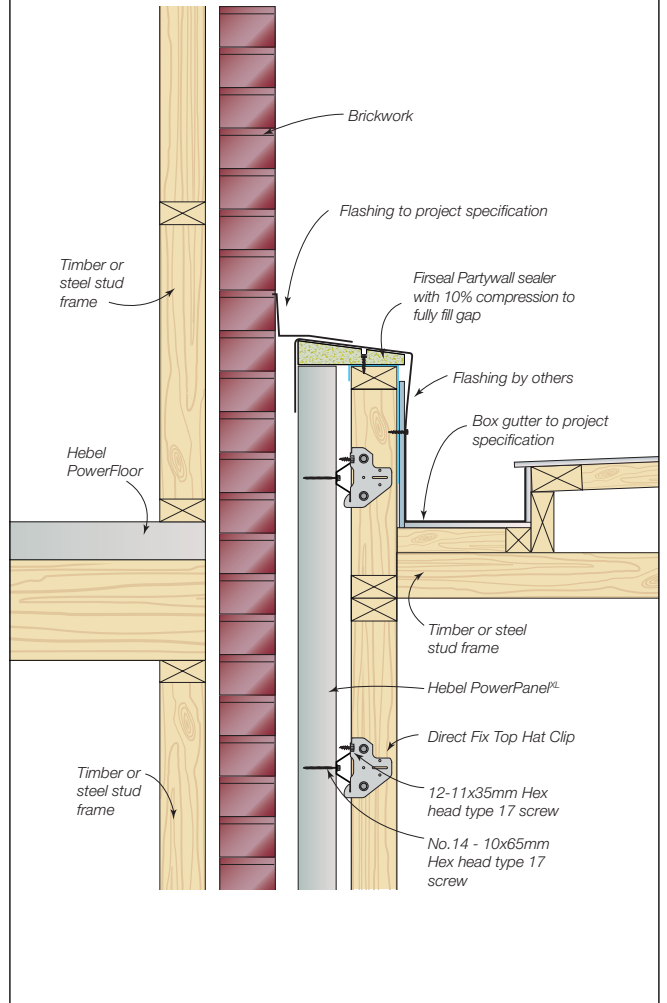
Figure 3.6.6.6 Balcony detail



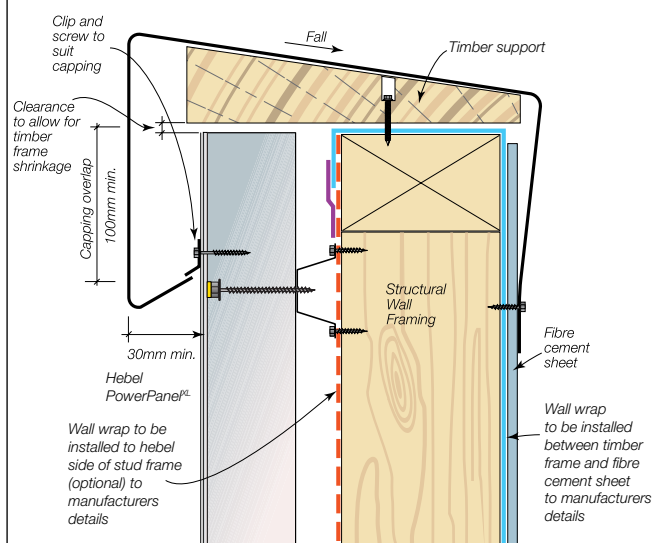
**Figure 3.6.6.7 Zero boundary wall detail to Hebel PowerPanel<sup>XL</sup> external wall system (Achieves FRL 90/90/90 when installed as part of the wall system. See Section 2.2)**



**Figure 3.6.6.8 Zero boundary wall detail to brick veneer (Achieves FRL 90/90/90 when installed as part of the wall system. See Section 2.2)**

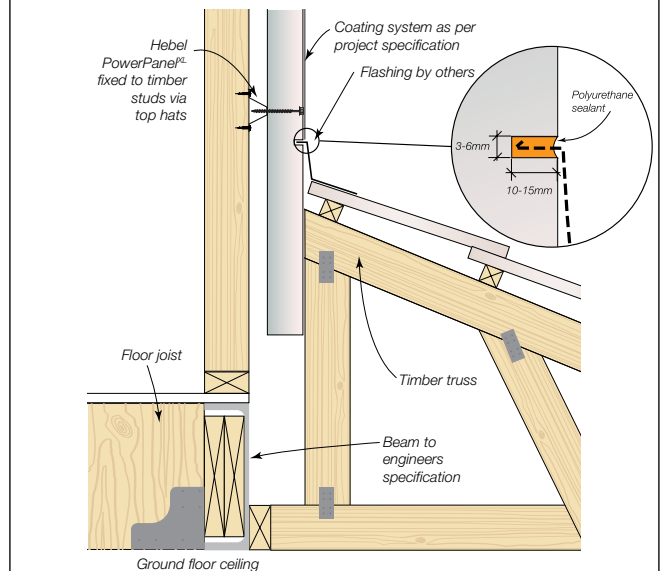


**Figure 3.6.6.9 Parapet capping**



**NOTE:**  
Parapet capping shall be designed and fastened in accordance with SAA – HB39 2015 – Installation Code for Metal Roofing and Wall Cladding. Stop ends shall be incorporated to all flashings.

**Figure 3.6.6.10 Hebel to pitched roof junction**



**NOTE:** Hebel PowerPanel<sup>XL</sup> panels are suspended from frame. Refer to tables 1.2.4 and 1.2.5 of this guide for design.

Figure 3.6.6.11 Gable end wall detail

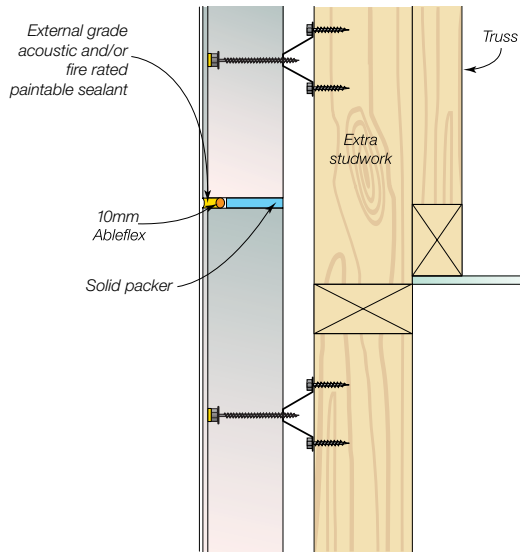


Figure 3.6.6.12 Gable end wall detail – lintel panel over window

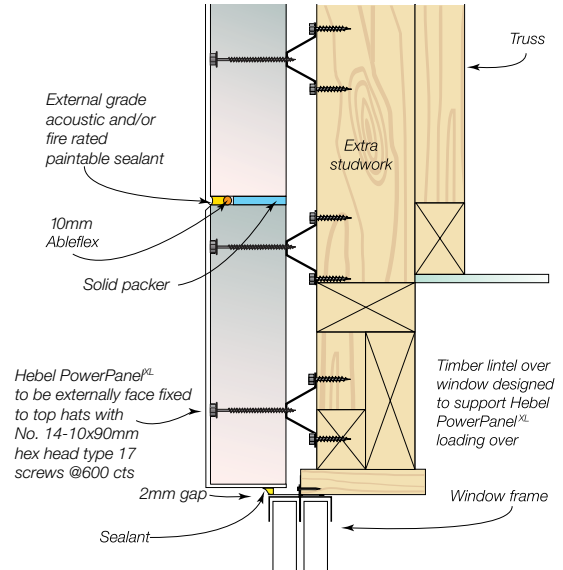


Figure 3.6.6.13 Beam penetration detail

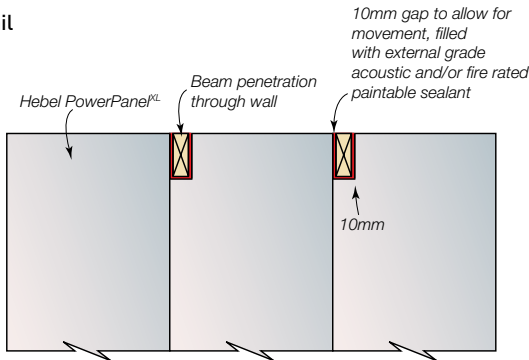
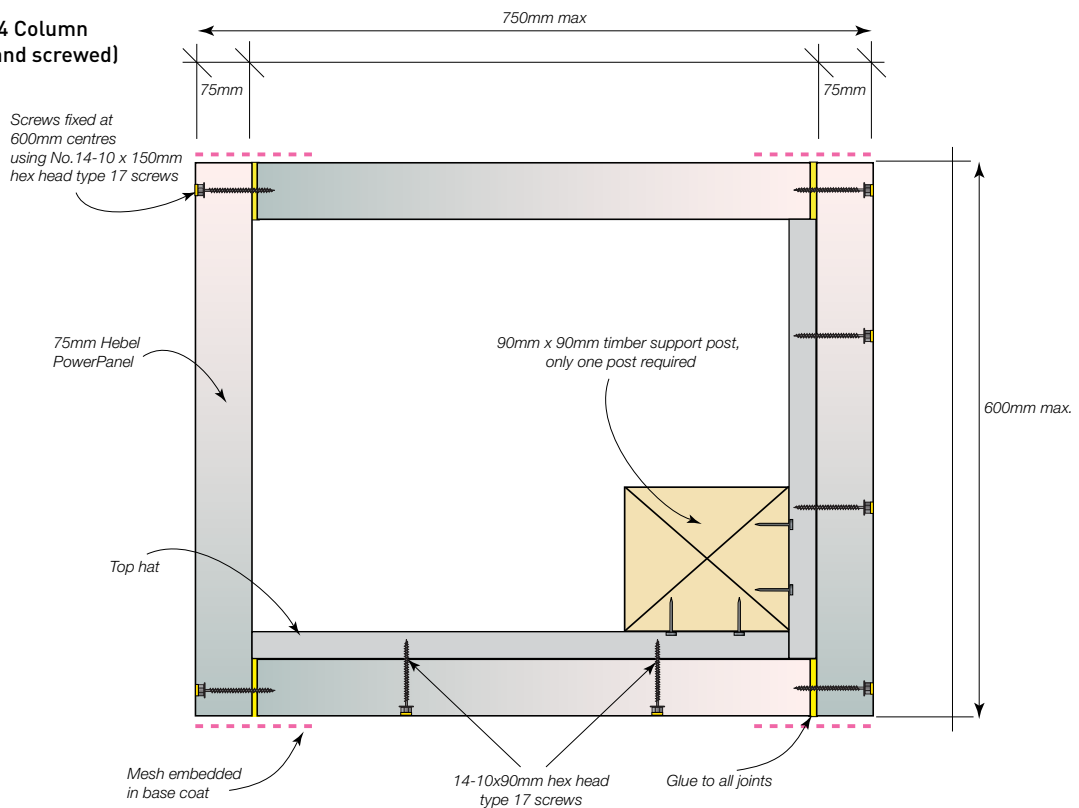


Figure 3.6.6.14 Column detail (glued and screwed)



### 3.6.7 CONTROL JOINTS

The following information provides the necessary rules for control jointing when installing the Hebel PowerPanel<sup>XL</sup> External Wall System:

- Refer section 1.3 for vertical control joint spacing (based on site classification)
- Vertical control joints required at external and internal corners
- Vertical control joints required above and below all doors, including sliding and garage doors
- Vertical control joints required at the position where a wall changes height by more than 20% e.g a vertical control joint is required when wall height changes from 2700mm to  $\geq 3240$ mm.
- Horizontal control joints required at every horizontal floor junction
- Horizontal control joints required at a maximum height of 3.9m.

#### For openings < 2450mm in width

- Control joint not required. If the straight joint that extends above or below the window jamb is less than 600mm long, a control joint or a glued and meshed joint is required.

#### For openings $\geq 2450$ mm and < 3600mm wide

- Control joint required to at least one side of the opening (i.e. above and below the opening). If the straight joint that extends above or below the window jamb is less than 600mm long a control joint or a glued and meshed joint is required to the opposite side of the opening.

#### For openings $\geq 3600$ mm in width

- Control joint required to both sides of the opening (i.e. above and below the opening).

#### NOTES:

1. The minimum lintel panel height above windows is 270mm.
2. Footing and slab design to comply with AS 2870.
3. Vertical control joints are not required to align between storeys of the building and can be terminated at the horizontal control joint located within the upper storey floor framing structure zone/depth.
4. The PowerPanel<sup>XL</sup> panels can be installed directly beside window or door openings (retaining a minimum 2-3mm gap between window jamb and panel) such that the control joint is only installed above and below the opening to the required width, negating the need to provide the width of the control joint directly beside the window or door. The 2-3mm gap is also required at the head of the window or door to the head panel.

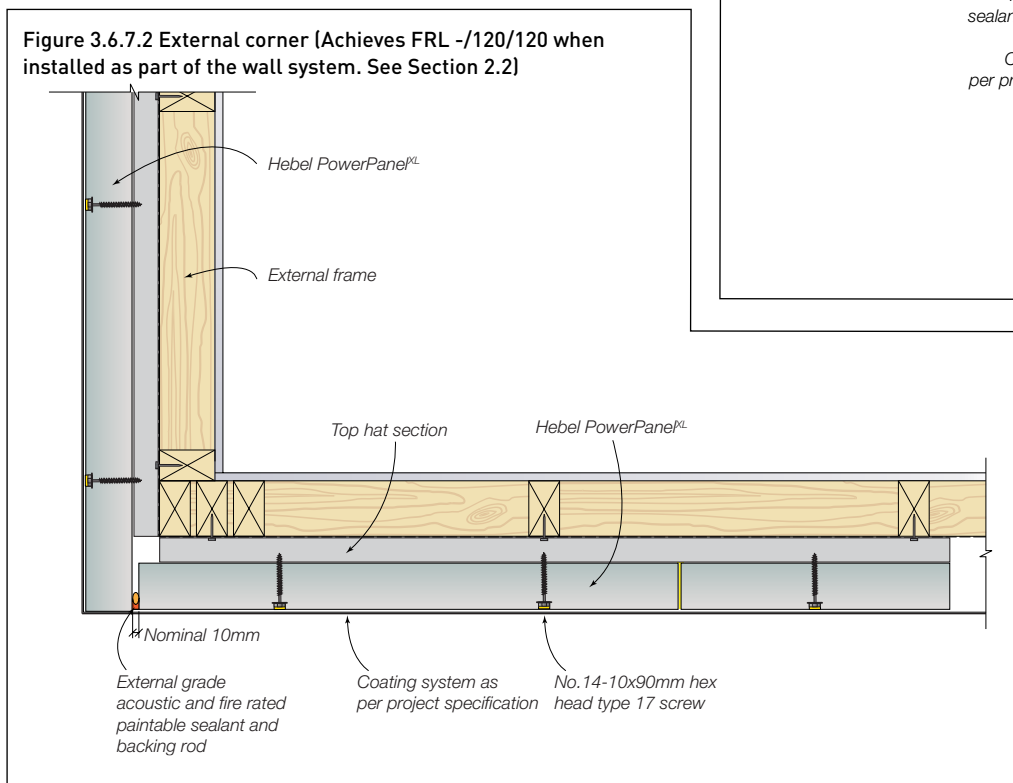
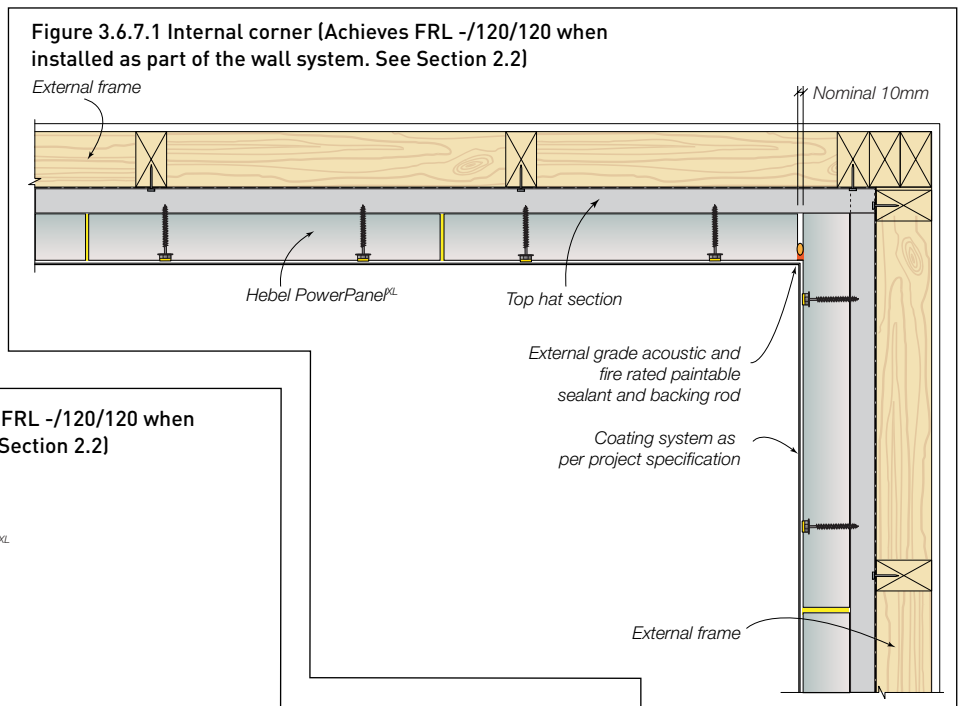


Figure 3.6.7.3 Typical detail for control joints positioned on corner

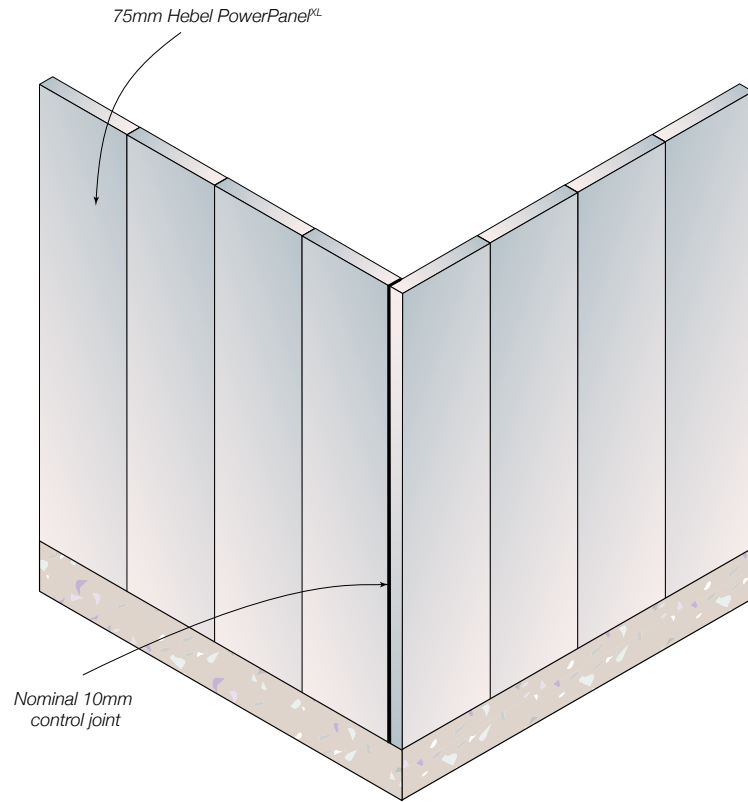
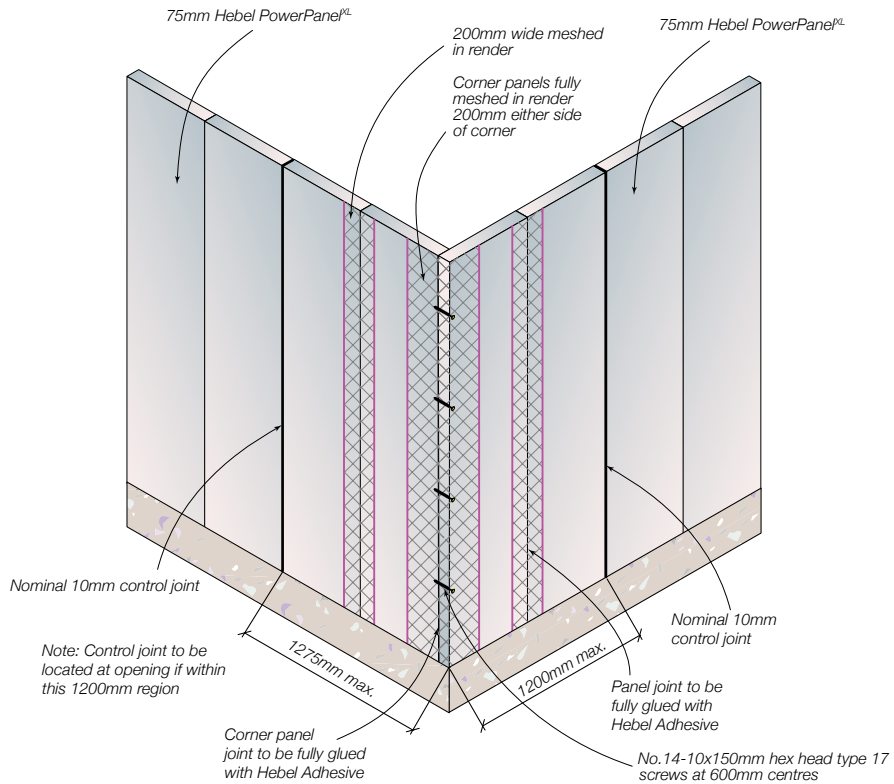
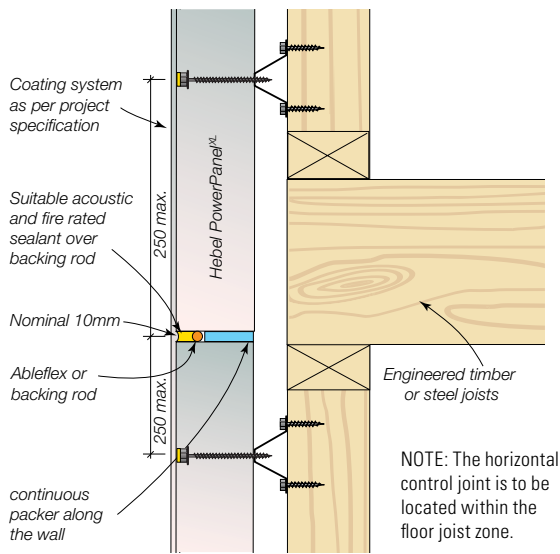


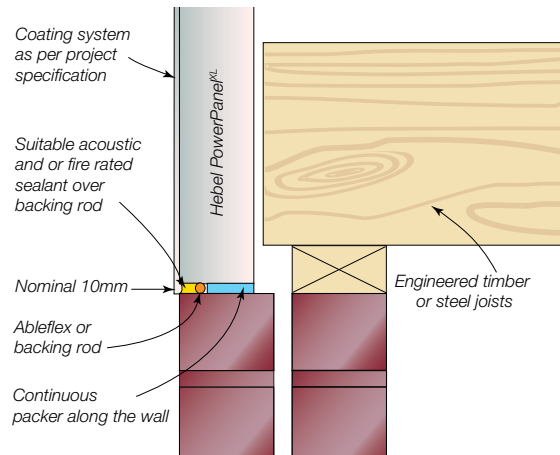
Figure 3.6.7.4 Typical detail for control joints positioned away from a corner



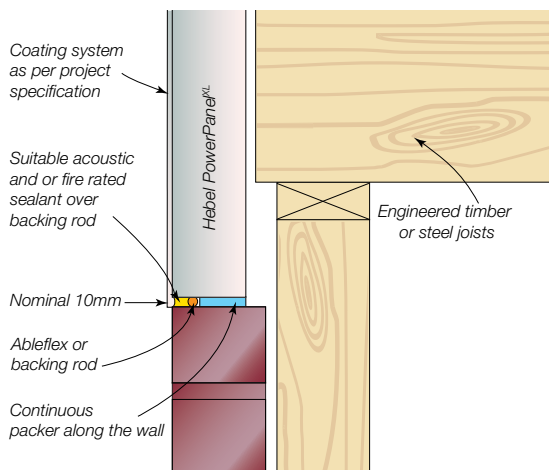
**Figure 3.6.7.5 Typical horizontal control joint – engineered timber or steel frame (Achieves FRL -/120/120 when installed as part of the wall system. See Section 2.2)**



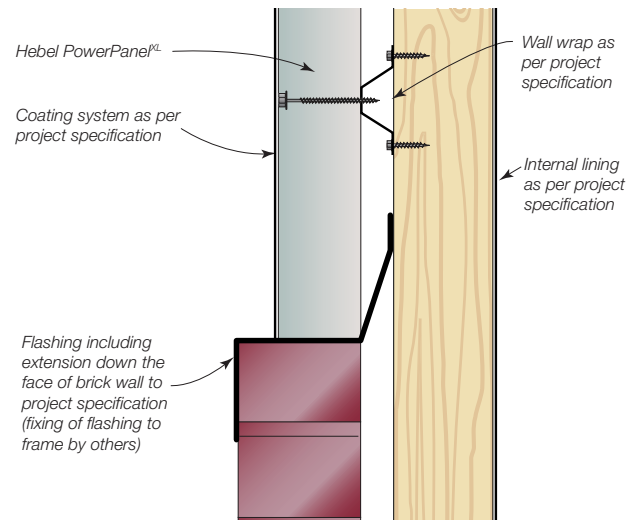
**Figure 3.6.7.6 Horizontal control joint – Cavity brickwork to Hebel PowerPanelXL**



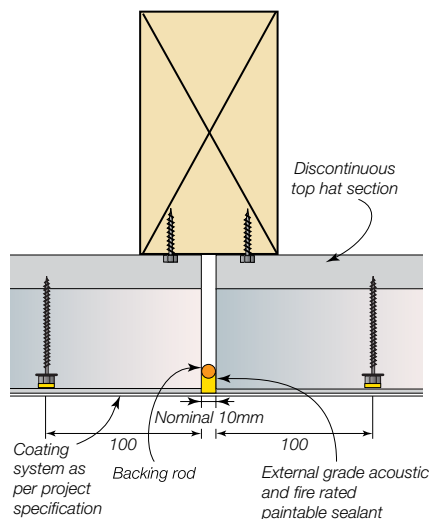
**Figure 3.6.7.7 Horizontal control joint – Brick veneer to Hebel PowerPanelXL - Option 1**



**Figure 3.6.7.8 Horizontal control joint – Brick veneer to Hebel PowerPanelXL - Option 2**



**Figure 3.6.7.9 Typical vertical control joint (Achieves FRL -/120/120 when installed as part of the wall system. See Section 2.2)**



**Figure 3.6.7.10 Typical vertical control joint with double studs (Achieves FRL -/120/120 when installed as part of the wall system. See Section 2.2)**

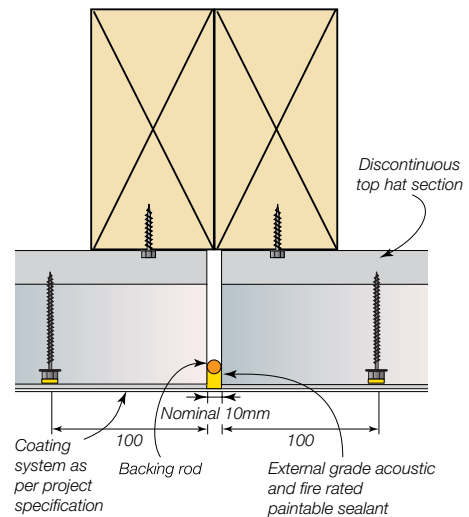


Figure 3.6.7.11 Control joint - aligned top hats on double stud

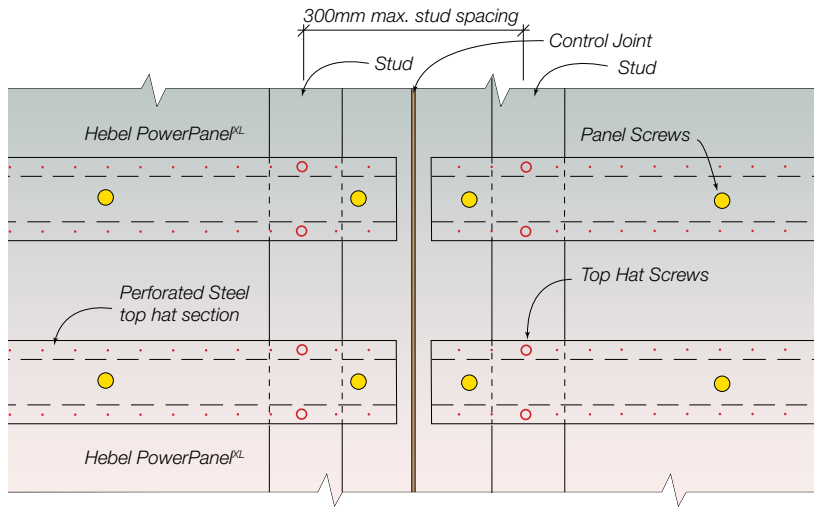


Figure 3.6.7.12 Control joint - discontinuous top hats on a single stud

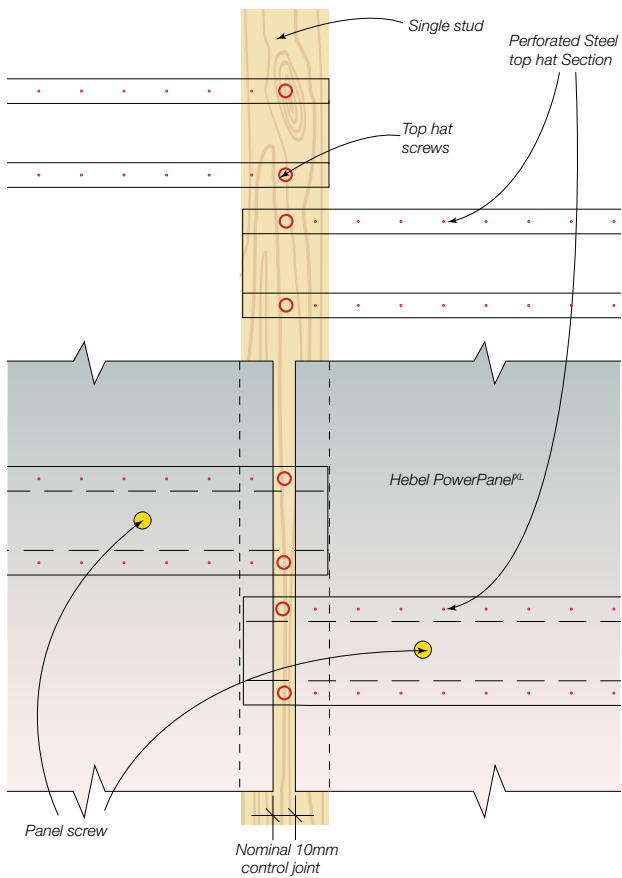
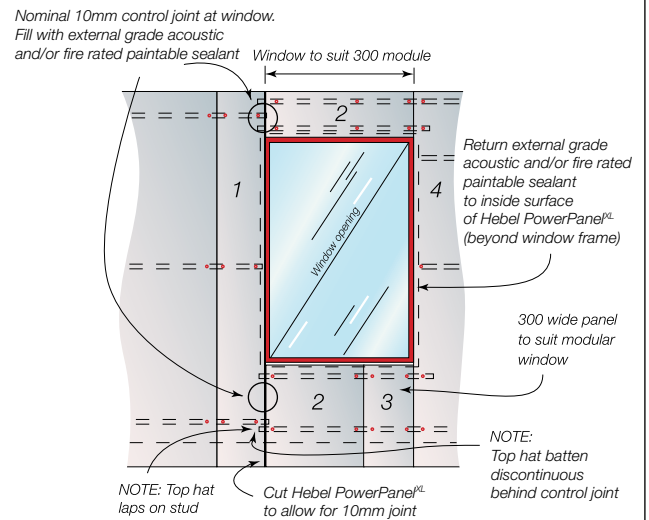
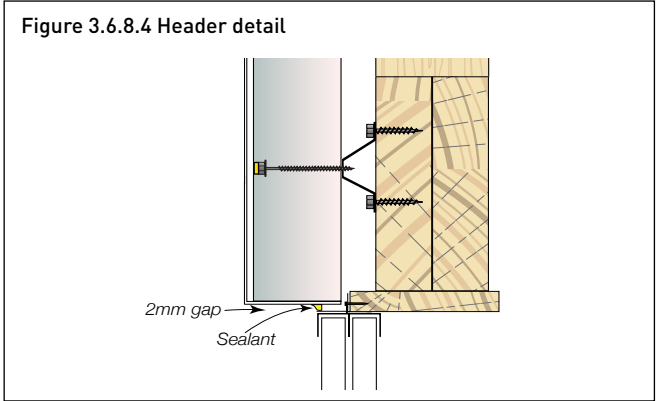
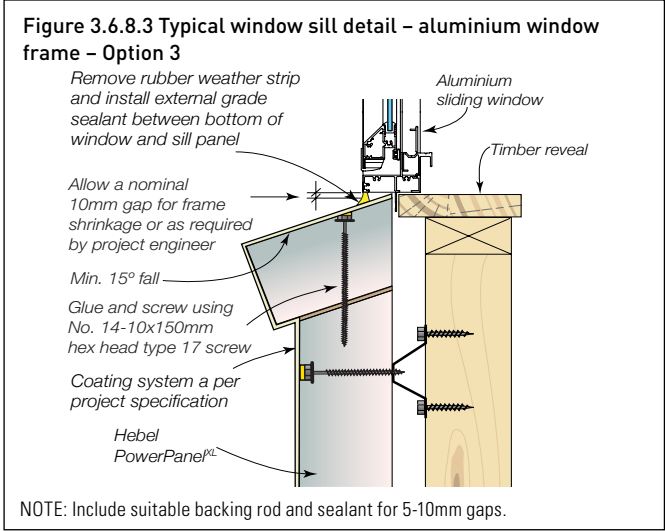
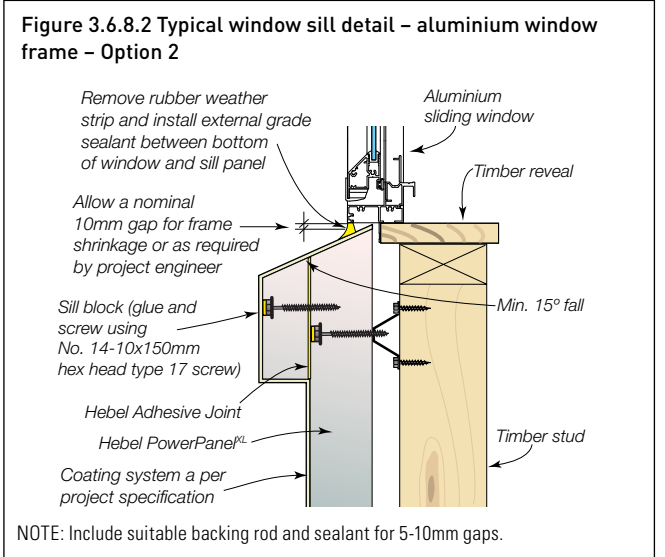
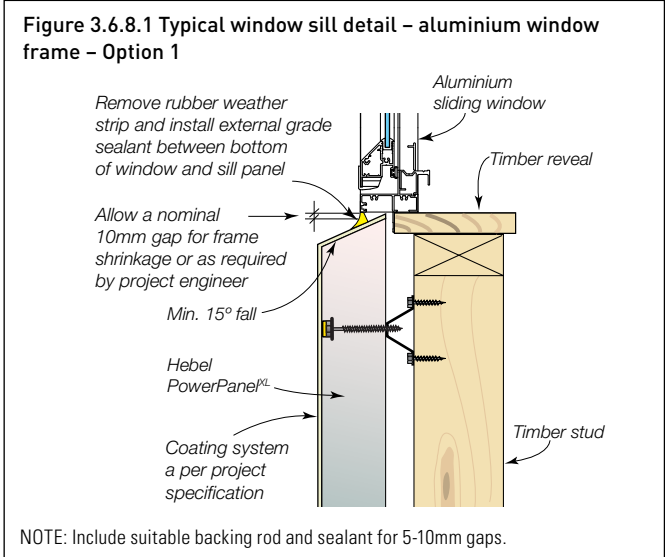


Figure 3.6.7.13 Typical window control joint detail - lintel over



NOTE:  
The installation sequence of the PowerPanel XL panels around the openings should be followed as numbered if there is no control joint at the opening, to maintain glue thickness on the edge of the panel.

### 3.6.8 DOOR & WINDOW DETAIL



NOTE: CSR Hebel recommends the removal of the rubber weather strip at the window sill prior to applying external grade sealant between the bottom of the window sill and panel. Windows shall be caulked around all sides to ensure that the system remains sealed and not allow water ingress into the cavity. The installation of any alternative details shall be the responsibility of the builder to provide supporting evidence that it meets the requirements of a sealed system and maintains a dry cavity.

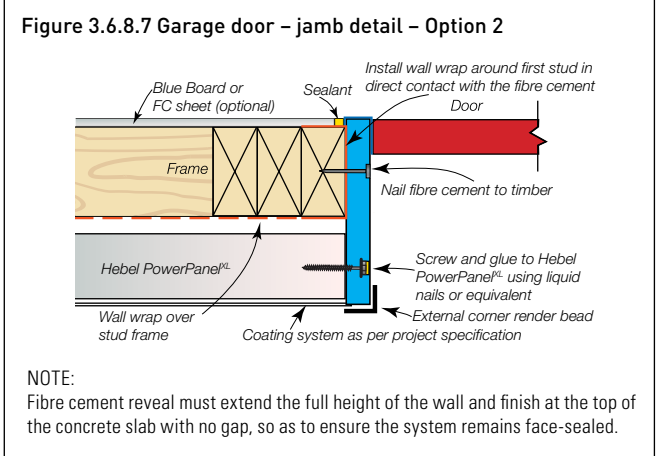
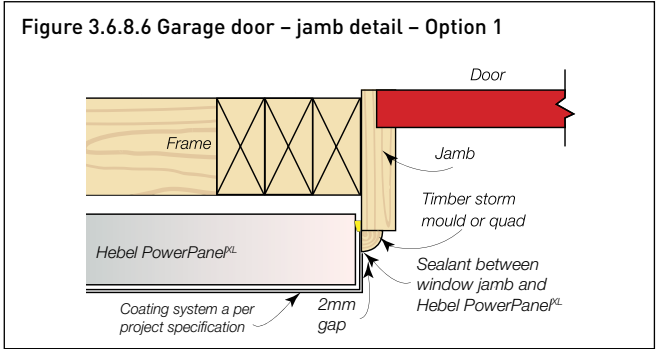
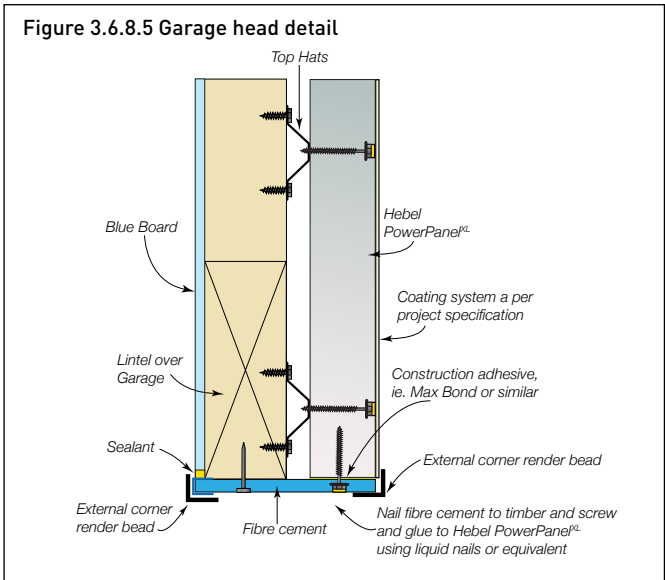




Figure 3.6.8.8 Sliding door sill detail – Concrete sill < 270mm

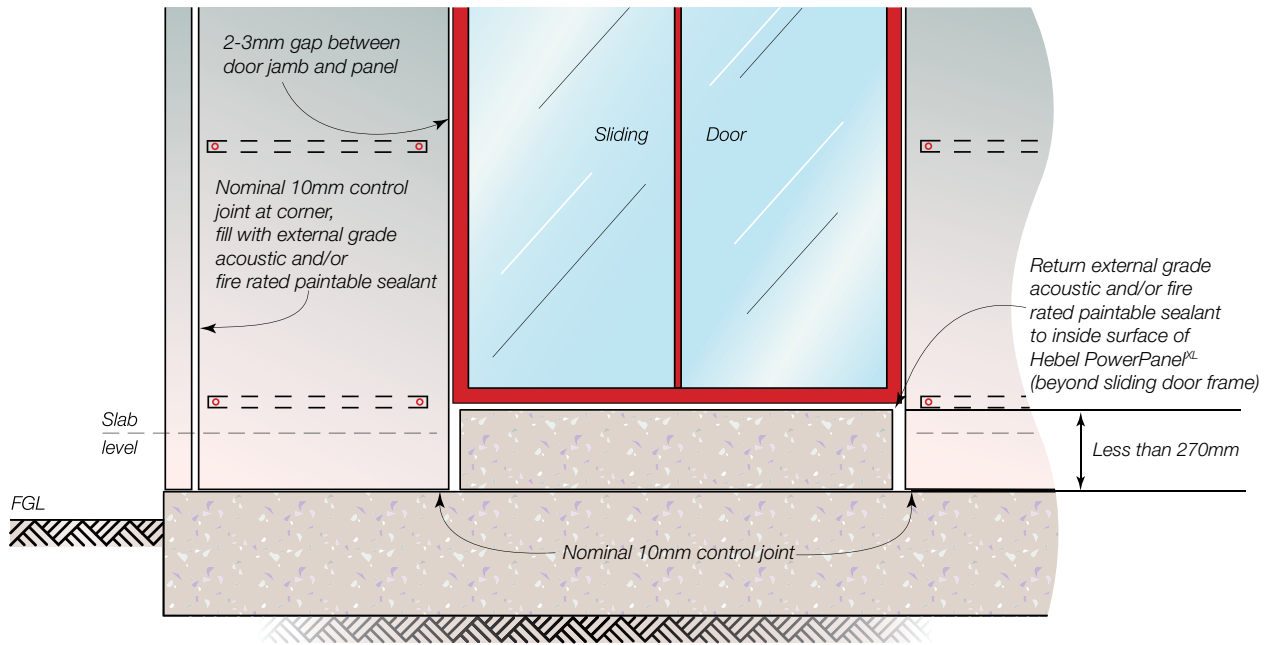
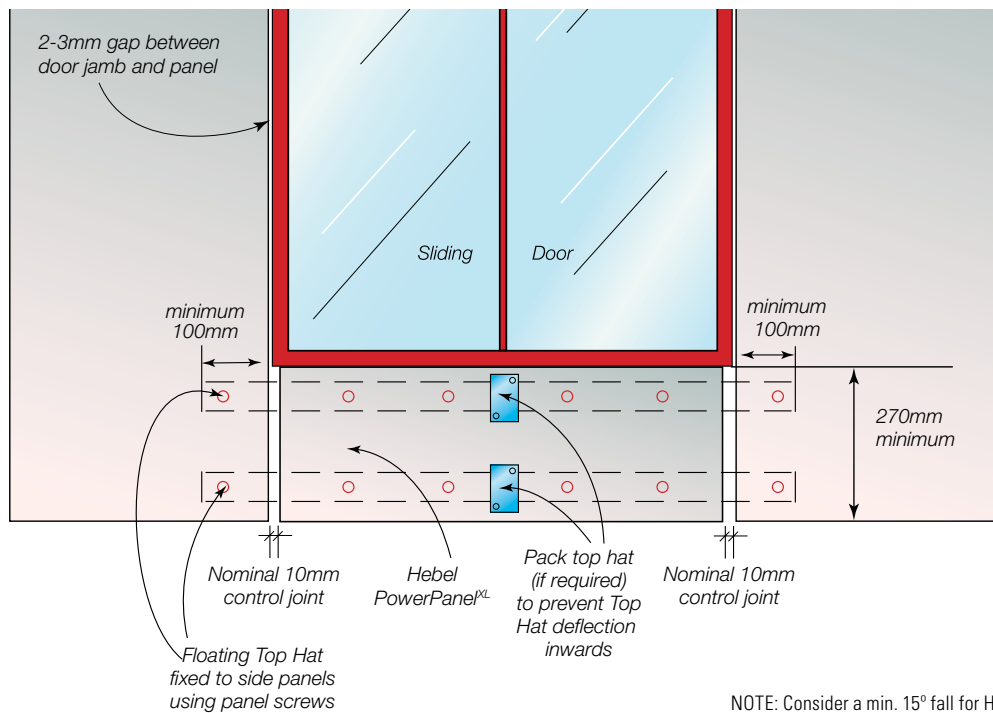
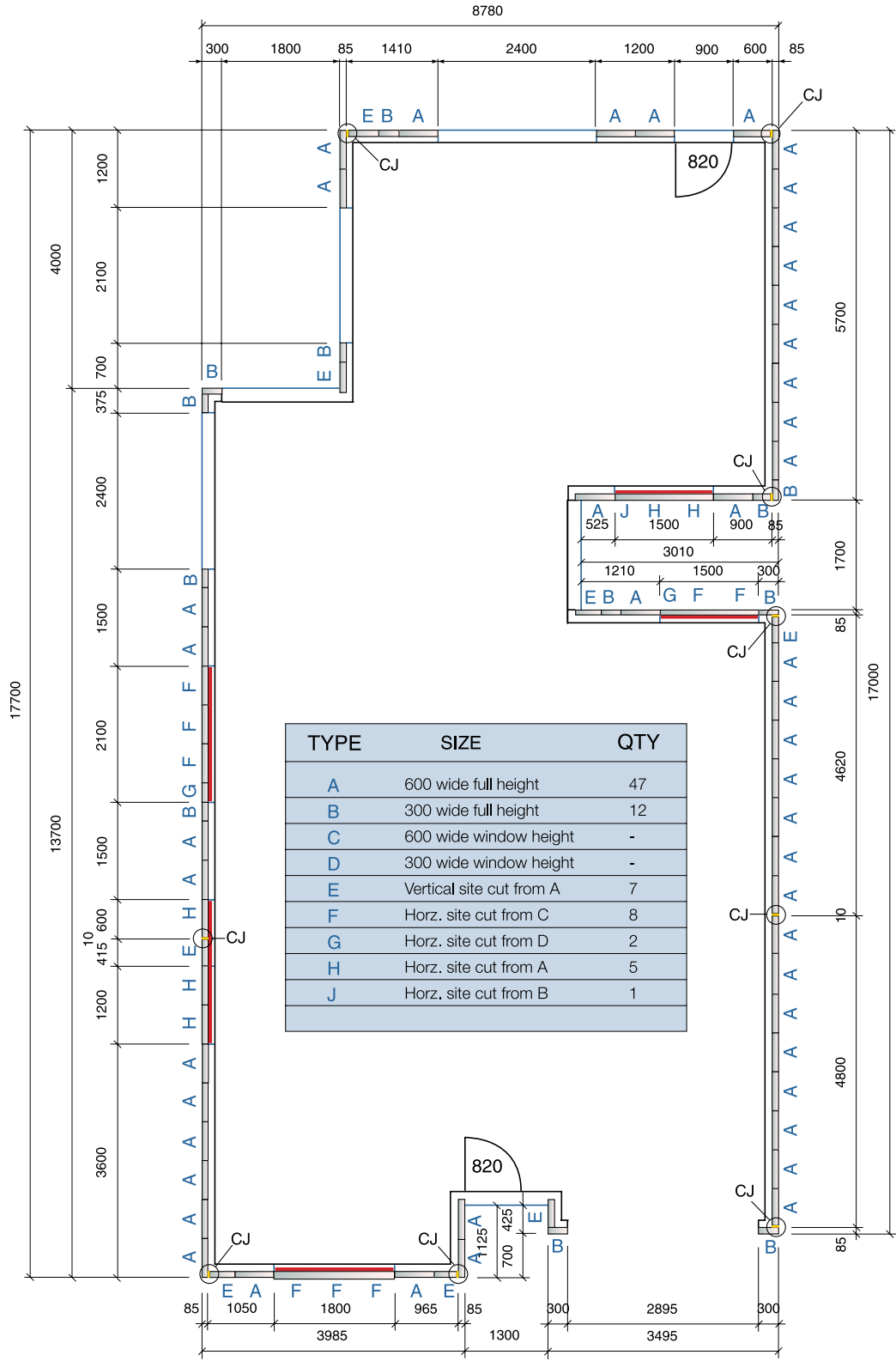


Figure 3.6.8.9 Sliding door sill detail – PowerPanel<sup>XL</sup> sill > 270mm



### 3.6.9 MISCELLANEOUS DETAIL

Figure 3.6.9.1 Panel layout drawing – Plan view



**NOTES:**

1. At corners, PowerPanel<sup>XL</sup> panels can be laid out at 300mm multiples in one direction and 300mm multiples + 85mm in the other direction
2. Width of PowerPanel<sup>XL</sup> panels may vary + or - 1.5mm

# 4.1 DELIVERY AND STORAGE

## UNLOADING PANEL PACKS

Panel packs should only be unloaded and moved with approved lifting devices. Before use, the lifting devices should be checked for the required lifting tags. Packs should be unloaded as close as possible to the intended installation area. This will increase work efficiency and minimise the need for secondary lifting.

NOTE: Secondary handling increases the risk of panel damage. The repair of damage sustained during lifting and moving is the responsibility of the lifter. Where damage is excessive, PowerPanel<sup>XL</sup> panels must be replaced.

## STORAGE

All materials must be kept dry and preferably stored undercover. Care should be taken to avoid sagging or damage to ends, edges and surfaces.

All Hebel products must be stacked on edge and properly supported off the ground, on a level platform. Panel bundles can be stacked two high. The project engineer should be consulted as to the adequacy of the structure to support the stacked bundles.

If outside, Hebel panels must be stored off the ground and protected from the weather. Only single bundles positioned

on the ground can be opened. To provide a level surface, we recommend placing temporary joists beneath the supporting cleats.

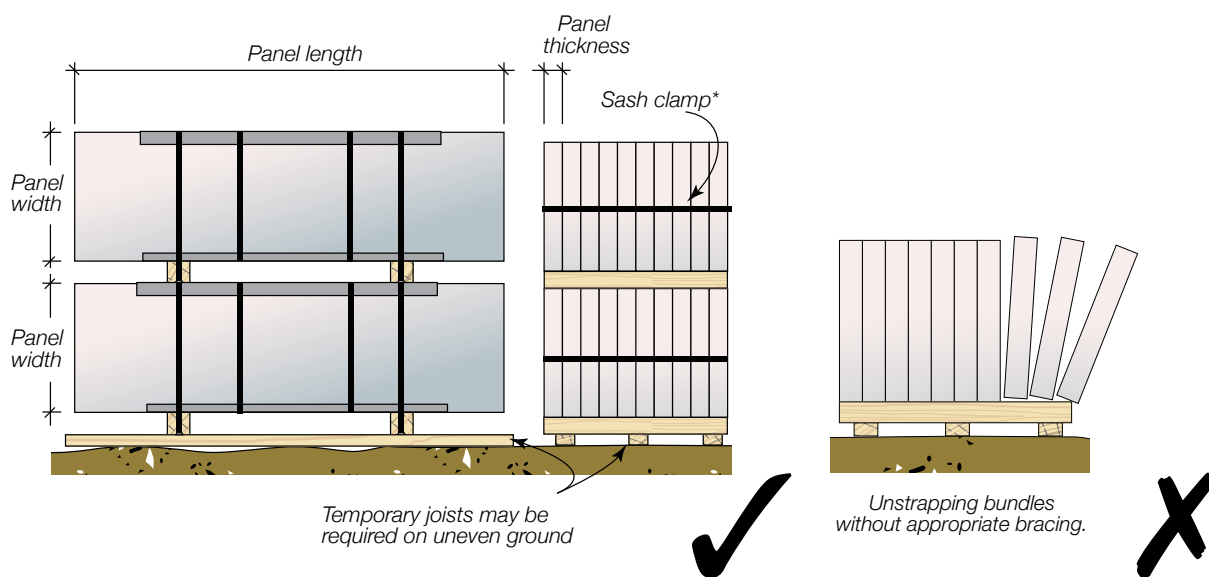
## UNSTRAPPING PACKS

Ensure appropriate bracing is installed to packs prior to removal of strapping to prevent panels from falling.

Panels can be held together with sash clamps, ratchet, straps or Hebel stabilising bars.



Figure 4.1 Stacking packs of Hebel PowerPanel<sup>XL</sup>



# 4.2 PANEL HANDLING

## MANUAL HANDLING

Hebel recommends using a trolley or other mechanical apparatus to move the PowerPanel<sup>XL</sup> panels around the work site. Manual handling where people physically move a panel should be kept to a minimum, with the weight being supported by an individual kept as small as possible. Any concerns regarding the weight to be handled should be discussed with the panel installation contractor.

To minimise the possibility of manual handling injuries, Hebel suggests the following:

- Use mechanical aids, such as trolleys, forklifts, cranes and levers, or team lifting to move panels
- Keep the work place clean to reduce the risk of slips, trips and falls, which can cause injury
- Plan the sequence of installation to minimise panel movements and avoid awkward lifts
- Train employees in good lifting techniques to minimise the risk of injury.

## HEBEL HOIST

Building back-to-back compliant zero boundary walls on site has been largely unachievable using traditional techniques. The difficulty includes ensuring that the walls are positioned correctly without overstepping their boundaries and that the installation techniques adopted do not in any way compromise fire performance of these walls.

Due to these issues and others such as ensuring that acoustic performance (as a minimum) achieves similar performance as that required of party walls, Hebel has developed an innovative hoisting solution that now makes it easy to install Zero boundary walls and vastly improves the efficiency of installing intertenancy walls in areas with limited access.

This revolutionary patented lifting device attaches directly to the frame and features a rail and hoist which allows panels to be safely lifted, transported and placed precisely from above before being fixed from the inside of the building.

Suitable for steel or timber frames up to three storeys high, the Hebel Hoist allows builders to streamline their workflow by erecting all the frames first before installing the external panels. It also has the potential to allow builders to increase the footprint of their buildings by moving external walls right up to the boundary.

The Hebel Hoist is only available through trained and accredited Hebel installers. Please contact your local Hebel sales representative or the Hebel customer service centre to discuss the opportunity to improve your efficiency and profitability using Hebel Hoist.

Figure 4.2.1 Hebel PowerPanel<sup>XL</sup> Trolley



Figure 4.2.2 Hebel Hoist



## MECHANICALLY ASSISTED HANDLING

Moving and handling Hebel panels should be done as much as possible using mechanical aids such as forklifts, cranes and special panels lifting trolleys.

Guidelines for handling Hebel PowerPanel<sup>XL</sup> using the PowerPanel<sup>XL</sup> Trolley or PowerPanel<sup>XL</sup> lifters are detailed in The Hebel Technical Manual Part 6.

## HEALTH, SAFETY & PERSONAL PROTECTIVE EQUIPMENT (PPE)

Hebel products are cement-based, which may irritate the skin, resulting in itching and occasionally a red rash. The wearing of gloves and suitable clothing to reduce abrasion and irritation of the skin is recommended when handling Hebel products.

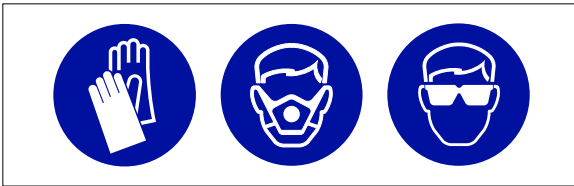
Approved respirators (AS/NZS 1715 and AS/NZS 1716) and eye protection (AS 1336) should be worn at all times when cutting and chasing. Refer to the Hebel Material Safety Data Sheets. Refer to the back of this Design & Installation Guide for further information regarding health and safety.

## CUTTING

The use of power tools when cutting concrete products may cause dust, which contains respirable crystalline silica, with the potential to cause bronchitis, silicosis and lung cancer after repeated and prolonged exposure. When using power or hand tools on Hebel products, wear a P2 respirator and eye protection. When cutting, routing or chasing Hebel products with power tools, use dust extraction equipment and wear hearing protection. Refer to the appropriate Hebel MSDS. For further information, contact Hebel or visit the website: [www.hebel.com.au](http://www.hebel.com.au)

Reinforcement exposed during cutting must be coated with a liberal application of Hebel Anti-corrosion protection paint.

Figure 4.2.3 Personal protective equipment



## 4.3 DESIGN, DETAILING AND PERFORMANCE RESPONSIBILITIES

Hebel engages independent testing laboratories to test and report on the performance of a wall in accordance with the relevant Australian Standards. Consultants use these reports as the basis for opinions (estimates of laboratory performance) they issue for variations or different arrangements to the tested system, and also to design and specify walls that meet appropriate criteria for a particular project. Using their experience, the consultant will make judgement about on-site installed performance of various walls. The performance levels of walls documented in this guide are either what is reported in a test or the documented opinion of consultants. Performance in projects is typically the responsibility of:

### PROJECT CONSULTANTS (STRUCTURAL, FIRE, ACOUSTIC, ETC.)

These consultants are typically responsible for the following:

- Opinions on expected laboratory performance of wall configurations that vary from actual test configuration, such as substitution products and components
- Judgements about expected field performance using laboratory test reports and practical experience
- Design, specification and certification of structural, fire, acoustic, durability, weather tightness and any other required performance criteria for individual projects

This involves the design and selection of building elements, such as wall and floors and their integration into the building considering the following:

- Interface of different building elements and to the structure / substrate
- Wall and floor junctions
- Penetrations
- Flashing issues
- Room / building geometry
- Acoustic and water penetration field-testing.

### PROJECT CERTIFIER AND/OR BUILDER

These professionals are typically responsible for:

- Identifying the performance requirements for the project in accordance with the National Construction Code and clearly communicating this to the relevant parties.
- Applicability of any performance characteristics supplied by Hebel including test and opinions for the project.
- The project consultant's responsibilities detailed above if one is not engaged in the project.

Hebel does not provide consulting services. Hebel only provides information that has been prepared by others and therefore shall not be considered experts in the field.

Any party using the information contained in this guide or supplied by Hebel in the course of a project must satisfy themselves that it is true, current and appropriate for the application, consequently accepting responsibility for its use.

It is the responsibility of the architectural designer and engineering parties to ensure that the details in this design guide are appropriate for the intended application.

The recommendations in this guide are formulated along the lines of good building practice, but are not intended to be an exhaustive statement of all relevant data.

Hebel is not responsible for the performance of constructed walls, including field performance, and does not interpret or make judgements about performance requirements in the NCC.

# APPENDIX A: HEBEL POWERPANEL<sup>XL</sup> MATERIAL PROPERTIES

## A.1 Manufacturing tolerances

Length	±5mm
Width	±1.5mm
Thickness	±1.5mm
Diagonals (max.)	5mm
Edge Straightness Deviation (max.)	1.5mm

## A.2 PowerPanel<sup>XL</sup> physical properties

- Hebel PowerPanel<sup>XL</sup> profile and nominal dimensions are shown in Section 1.4.
- Panel reinforcement is a single layer of steel mesh with 4 longitudinal wires of 4mm diameter.
- Nominal dry density = 400 kg/m<sup>3</sup>.
- Average working density = 540 kg/m<sup>3</sup> at 35% moisture content.
- Average service life density = 440 kg/m<sup>3</sup> at 10% moisture content.
- Hebel PowerPanel<sup>XL</sup> is manufactured in a range of stock sizes as detailed below:

Panel weight (kg)		
Length (mm)	Width (mm)	Weight (kg) at 35% M.C.
2400	600	58
2550	600	62
2700	600	66
2800	600	68
2850	600	69
3000	600	73
3300	600	80

NOTE: 75mm PowerPanel 1200 x 600mm weight 37kg.  
75mm PowerPanel 1800 x 600mm weight 56kg.

## A.3 PowerPanel<sup>XL</sup> strength properties

- Characteristic Compressive Strength or AAC,  $f'_{m} = 2.38$  MPa.
- Average Compressive Strength of AAC = 2.8 MPa.
- Characteristic Modulus of Rupture,  $f'_{ut} = 0.40$  MPa.

## A.4 PowerPanel<sup>XL</sup> acoustic properties

- Panel only with no plasterboard or other lining  
 $R_W = 34$ dB,  $R_{W+C_{tr}} = 30$ dB (refer to Acoustic Logic Test Report ref: 2010861.15/2602A/R2 GW).

## A.5 PowerPanel<sup>XL</sup> thermal properties

- R-Value of PowerPanel<sup>XL</sup> with no plasterboard or other lining = 0.520 m<sup>2</sup>.K/W (4% moisture content).

## A.6 Fire hazard indices

Hebel products have BCA Group Number 1 and also the following early fire hazard indices, determined in accordance with AS1530.3:1990:

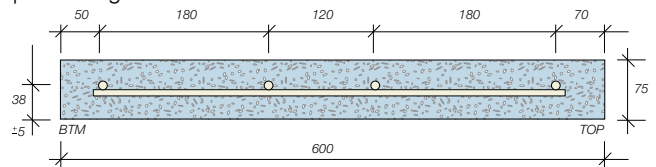
Ignitability Index	0
Spread of Flame Index	0
Heat Development Index	0
Smoke Development Index	0-1

## A.7 Fire Resistance Level (FRL) Ratings

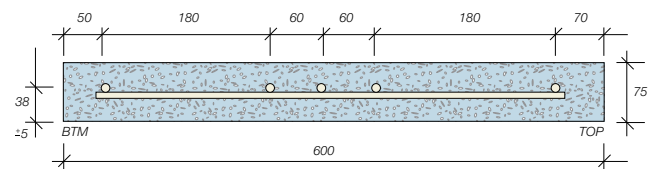
For fire performance characteristics of Hebel PowerPanel<sup>XL</sup>, refer to Section 2.2 of this guide.

## A.8 Typical Hebel PowerPanel<sup>XL</sup> cross section

Typical Hebel Powerpanel<sup>XL</sup> cross section for 2400 - 3000mm panel length:



Typical Hebel Powerpanel<sup>XL</sup> cross section for 3300mm panel length:



### NOTES:

1. BTM: To locate the approximate location of reinforcing the smooth edge of the panel is the bottom (BTM).
2. Bars: 4x4mm Ø longitudinal & 6-8 transverse bars depending on panel length.
3. Tolerance: The width & thickness of PowerPanel<sup>XL</sup> panels are manufactured to a tolerance of +1 or -1.5mm.
4. Cutting: Panels typically to be no less than 270mm wide. Where narrower panels are used, these panels must not be less than 100mm in width and must be installed between full width panels. Reinforced fibreglass mesh to be embedded in base levelling coat across the full width of the narrower panel.  
In cases where the installation is such that a panel as narrow as 100mm in width is to be installed on its own i.e such as between two adjacent window or door openings, then this installation method is deemed acceptable provided that this narrow panel can be cut, handled and installed without the panel cracking or becoming damaged (damaged or cracked panels must be discarded). In these cases, reinforced fibreglass mesh is to also be embedded in base levelling coat across the full width of this narrow panel.

# APPENDIX B: POWERPANEL<sup>XL</sup> EXTERNAL WALL SYSTEM DESCRIPTIONS

## C.1: Hebel PowerPanel<sup>XL</sup> External Wall System - timber stud frame

Hebel code	Description					
	Platerboard	Stud frame	Batts	Wall wrap	Top hat cavity	Hebel Panel
Hebel1716	10mm Gyprock Plasterboard Plus	70mm timber Stud frame	None	Polyair Performa 4.0 XHD	24mm	75mm thick Hebel PowerPanel <sup>XL</sup>
Hebel1717			70mm Bradford Soundscreen Batts R2.0	Thermoseal Wall Wrap XP		
Hebel1718			70mm Bradford Soundscreen Batts R2.0	Enviroseal ProctorWrap RW		
Hebel1721			None	Polyair Performa 4.0 XHD	35mm	
Hebel1722			70mm Bradford Soundscreen Batts R2.0	Thermoseal Wall Wrap XP		
Hebel1723			70mm Bradford Soundscreen Batts R2.0	Enviroseal ProctorWrap RW		
Hebel1726		90mm timber Stud frame	None	Polyair Performa 4.0 XHD	24mm	
Hebel1727			90mm Bradford Gold Wall Batts R2.0	Thermoseal Wall Wrap XP		
Hebel1728			90mm Bradford Gold Wall Batts R2.5	Enviroseal ProctorWrap RW		
Hebel1730			90mm Bradford Gold Wall Batts R2.7	Enviroseal ProctorWrap RW		
Hebel1733			None	Polyair Performa 4.0 XHD	35mm	
Hebel1734			90mm Bradford Gold Wall Batts R2.0	Thermoseal Wall Wrap XP		
Hebel1735			90mm Bradford Gold Wall Batts R2.5	Enviroseal ProctorWrap RW		
Hebel1737			90mm Bradford Gold Wall Batts R2.7	Enviroseal ProctorWrap RW		



C.2: Hebel PowerPanel<sup>XL</sup> External Wall System - steel stud frame

Hebel code	Description					
	Platerboard	Stud frame	Batts	Wall wrap	Top hat cavity	Hebel Panel
Hebel1706	10mm Gyprock Plasterboard Plus	64mm steel Stud frame	None	Polyair Performa 4.0 XHD	24mm	75mm thick Hebel PowerPanel <sup>XL</sup>
Hebel1707			70mm Bradford Soundscreen Batts R2.0	Thermoseal Wall Wrap XP		
Hebel1708			70mm Bradford Soundscreen Batts R2.0	Enviroseal ProctorWrap RW		
Hebel1711			None	Polyair Performa 4.0 XHD	35mm	
Hebel1712			70mm Bradford Soundscreen Batts R2.0	Thermoseal Wall Wrap XP		
Hebel1713			70mm Bradford Soundscreen Batts R2.0	Enviroseal ProctorWrap RW		
Hebel1740		92mm steel Stud frame	None	Polyair Performa 4.0 XHD	24mm	
Hebel1741			90mm Bradford Gold Wall Batts R2.0	Thermoseal Wall Wrap XP		
Hebel1742			90mm Bradford Gold Wall Batts R2.5	Enviroseal ProctorWrap RW		
Hebel1744			90mm Bradford Gold Wall Batts R2.7	Enviroseal ProctorWrap RW		
Hebel1747			None	Polyair Performa 4.0 XHD	35mm	
Hebel1748			90mm Bradford Gold Wall Batts R2.0	Thermoseal Wall Wrap XP		
Hebel1749			90mm Bradford Gold Wall Batts R2.5	Enviroseal ProctorWrap RW		
Hebel1751			90mm Bradford Gold Wall Batts R2.7	Enviroseal ProctorWrap RW		





## CSR HEBEL

Trinity 3, 39 Delhi Road  
North Ryde NSW 2113, Australia  
Telephone +61 2 9235 8000

### Health & safety

Information on any known health risks of our products and how to handle them safely is on product packaging and / or the accompanying documentation.

Additional information is listed in the Material Safety Data Sheet (MSDS). To obtain a copy of a MSDS, download from [www.hebel.com.au](http://www.hebel.com.au). Contractors are required by law to perform their own risk assessments before undertaking work.

### Performance & certification

Hebel® products and systems are developed in Australia by CSR Building Products. ABN. 55 008 631 356. It is a manufacturer and supplier of Hebel Autoclaved Aerated Concrete (AAC) products. Because it is a manufacturer and supplier only, CSR does not employ people qualified as Accredited or Principal Certifiers.

CSR is therefore unable to provide Construction Compliance Certificates or Statements of Compliance. CSR conducts appropriate testing of its products and systems to determine performance levels. These include structural, fire and acoustic tests. Testing is conducted and certified by appropriate specialists in these fields. When using Hebel products and systems in specific projects, such specialists should be consulted to ensure compliance with the Building Code of Australia and relevant Australian Standards.

### Disclaimer

Information presented in this document is supplied in good faith and to the best of our knowledge was accurate at the time of preparation. The provision of this information should not be construed as a recommendation to use any of our products in violation of any patent rights or in breach of any statute or regulation. Users are advised to make their own determination as to the suitability of this information in relation to their particular purpose or specific circumstances. Since the information contained in this document may be applied under conditions beyond our control, no responsibility can be accepted by CSR, or its staff for any loss or damage caused by any person acting or refraining from action as a result of misuse of this information.

### Other

The design of a wall, floor or fence system requires the services of professional consultants. This document has been prepared as a source of information to provide general guidance to those consultants – and in no way replaces the services of the professional consultant and relevant engineers designing the project.

No liability can therefore be accepted by CSR or other parties for the use of this document. Hebel products and systems undergo constant research and development to integrate new technology and reflect ongoing performance enhancement.

Hebel systems are constantly reviewed so as to reflect any changes in legislative building requirements and or general developments in common building practice, due to our commitment to continual development and improving our building systems.

We advise that all users of this document should regularly check that this document is current, and they are applying our latest design information.

The latest editions of our documents are available on our website:  
[www.hebel.com.au](http://www.hebel.com.au)

Hebel® is a registered trademark of the Xella group. CSR Building Products Ltd is an exclusive licensee of Xella. CSR Hebel is a business of CSR Building Products Ltd ABN 55 008 631 356.

CSR, PowerPanel®, PowerClad®, Hebel Block®, PowerFloor®, Hebel Floor®, PowerFence®, HighBuild®, are registered trademarks of CSR Building Products Limited.

## THE BETTER WAY TO BUILD

Hebel is a quality building product, and is backed by CSR Building Products Limited.

For more information visit our website:

[www.hebel.com.au](http://www.hebel.com.au)

For sales enquiries or further information, please telephone us from anywhere in Australia:

1300 369 448

