

# Houses and Low Rise Multi Residential PowerPanelXL External Walls

DESIGN AND  
INSTALLATION GUIDE

# CONTENTS

This Design and Installation Guide has been prepared as a source of information to provide general guidance to consultants – and in no way replaces the services of the professional consultant and relevant engineers designing the project.

It is the responsibility of the architectural designer and engineering parties to ensure that the details in this Design and Installation Guide are appropriate for the intended application.

The recommendations of this guide are formulated along the lines of good building practice, but are not intended to be an exhaustive statement of all relevant data.

<b>Introduction</b>	<b>1</b>
<b>1. Design and selection details</b>	<b>4</b>
1.1 Designing an external wall using Hebel PowerPanelXL	4
1.2 Structural provisions	5
1.3 Design & detailing considerations	10
1.4 System components	12
<b>2. System performance</b>	<b>14</b>
2.1 Durability	14
2.2 Fire resistance performance	16
2.3 Energy efficiency	17
2.4 Sound transmission and insulation	21
2.5 Coating requirements	22
2.6 Weatherproofing	23
<b>3. Installation detail</b>	<b>24</b>
3.1 Hebel PowerPanelXL installation sequence	24
3.2 Tools and equipment for construction	25
3.3 Installation of services	25
3.4 External Aluminium render bead	25
3.5 Construction details – overview	26
3.6 Construction details	28
<b>4. Handling, storage and responsibility</b>	<b>50</b>
4.1 Delivery and storage	50
4.2 Panel handling	51
4.3 Design, detailing and performance responsibilities	54
<b>Appendices</b>	<b>55</b>
Appendix A: Hebel PowerPanelXL material properties	55
Appendix B: PowerPanelXL external wall system descriptions	56



# WHY HEBEL® SYSTEMS ARE A BETTER WAY TO DESIGN AND BUILD

Whether you're a developer, architect, designer, builder or wall installer, Hebel wall systems deliver exceptional advantages in terms of performance, quality, speed, efficiency, risk minimisation and sustainability values.

## Creating high performance buildings using Hebel PowerPanel<sup>XL</sup>

At the heart of the Hebel external wall system for houses and low-rise multi-residential projects is the Hebel PowerPanel<sup>XL</sup> - a 75mm thick steel reinforced panel made from autoclaved aerated concrete (AAC).

Developed and warranted by CSR, the Hebel PowerPanel<sup>XL</sup> can reduce heating and cooling loads on buildings and is non-combustible. It can be produced to the size needed, is easily cut, makes construction fast and efficient, creates minimal waste and is a better choice for the environment compared with concrete or brick.

As with all Hebel reinforced panel products, PowerPanel<sup>XL</sup> conforms to the Australian Standard for Reinforced Autoclaved Concrete (AAC), AS 5146.

## Construction speed and efficiency

The Hebel PowerPanel<sup>XL</sup> External Wall System speeds up the build process at the same time as delivering a superior finished product – a key reason why developers, builders and owner / builders choose Hebel. For instance, one standard Hebel panel is the equivalent of 75 traditional bricks, which means the walls of a 150m<sup>2</sup> home can go up in as little as three days when installed by experienced Hebel installers.

## Minimising risk

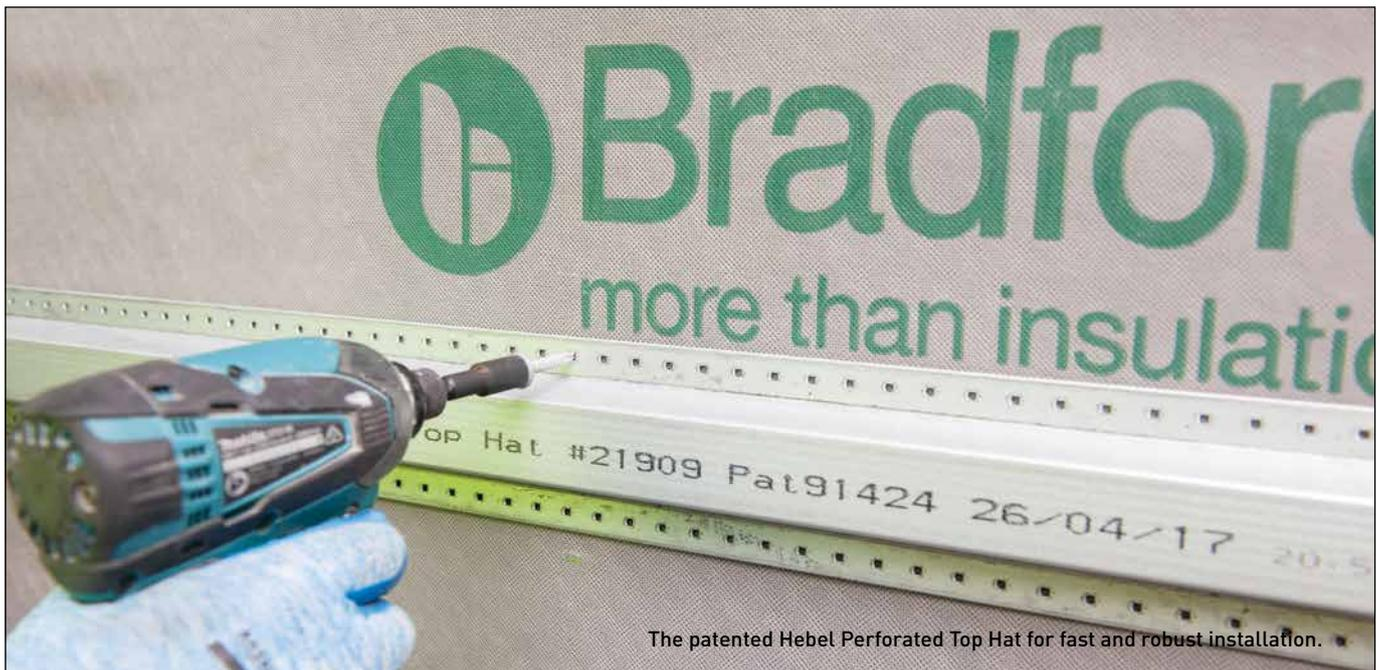
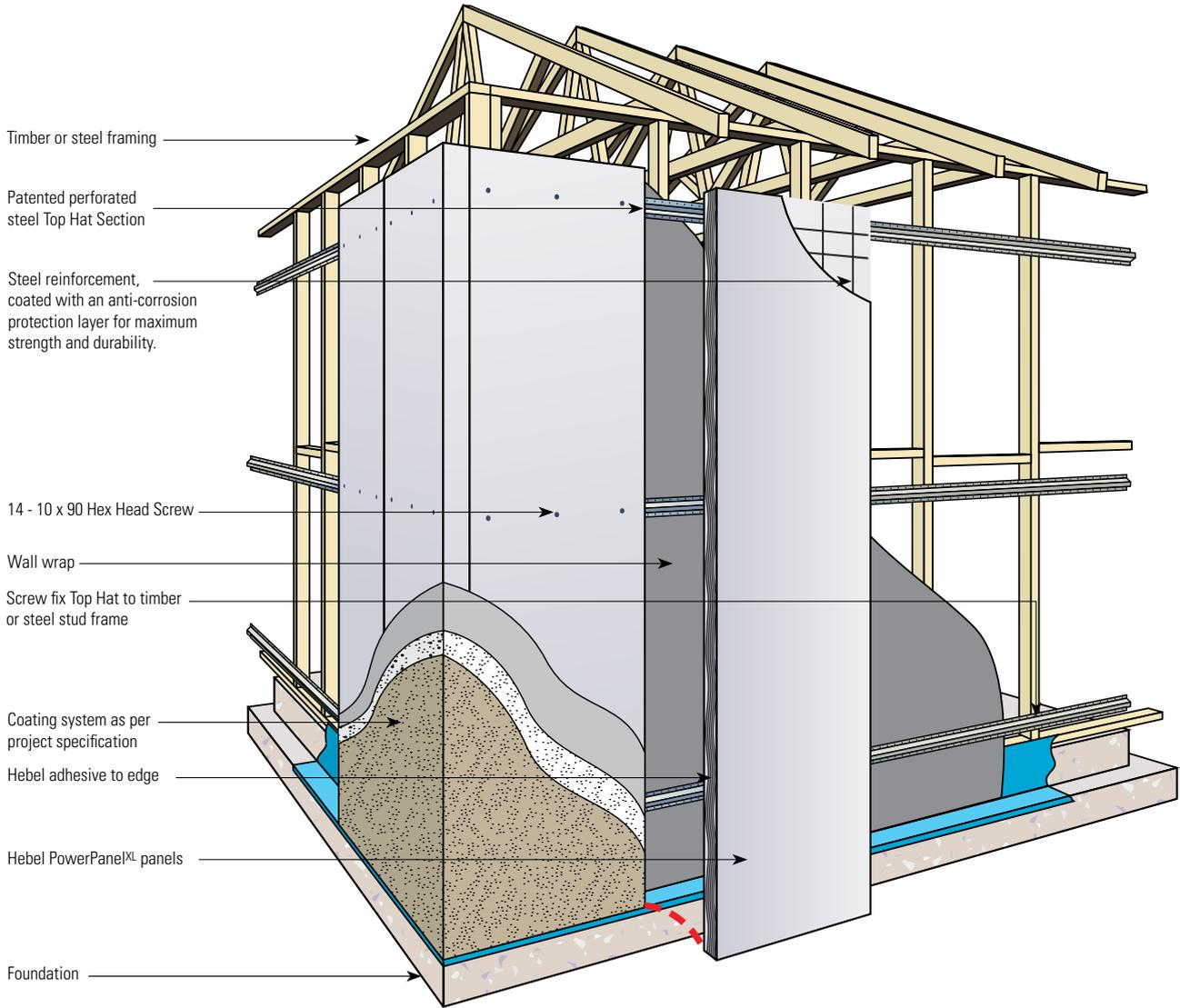
Hebel wall systems provide a solid foundation for risk minimisation in design and construction. They are tested, well proven and designed to achieve NCC fire and thermal compliance easily. Combining the non-combustible property of PowerPanel<sup>XL</sup> with advanced system designs, CSR Hebel delivers high value cost effective solutions that significantly reduce risk points in construction. **Leveraging the exceptional value-add of Hebel systems**

Quite simply the Hebel PowerPanel<sup>XL</sup> External Wall System for houses and low rise multi-residential projects delivers a holistic solution that no other systems can match. It benefits all stakeholders in the project lifecycle through its role in value-adding to the project's quality, design and construction efficiency, risk minimisation and cost and time certainty.



75mm steel reinforced Hebel PowerPanel<sup>XL</sup>. For fast construction with minimised waste, 600mm wide panels can be in ordered in stock lengths of 2400, 2550, 2700, 2800, 2850, 3000 and 3300mm.

Typical home construction application



# BENEFITS OF BUILDING WITH HEBEL



## STRONG AND SOLID

Hebel panels are high-performance building products made from autoclaved aerated concrete (AAC) containing steel reinforcement for added strength, with an anti-corrosion layer on the steel for maximum durability.



## ENERGY EFFICIENT

Hebel panels perform well thermally, helping to keep your house cool from the heat in summer, and keeping it warm and cosy in winter. That means less reliance on heating and cooling, and can lead to savings on energy costs.



## QUALITY AND SPEED

Building with Hebel can mean faster construction times, without sacrificing on quality. One standard Hebel panel is the equivalent of 75 traditional bricks, which means the external walls of a 150m<sup>2</sup> home can go up in just 3 days when installed by experienced Hebel installers. A high quality building material, Hebel provides a great solution in terms of speed and ease of construction which is why it is increasingly becoming the preferred choice of builders and developers.



## SUSTAINABLE

Hebel is made using readily available raw materials. Some of the waste generated in the manufacturing process is recycled, even down to the condensation that's produced.

Lightweight and easy-to-install, Hebel is available in custom sizes, reducing construction waste and enables fast installation, all of which help reduce the total energy consumed during construction.



## NOISE REDUCTION

A Hebel home is a quiet one. Building your home in Hebel can significantly reduce the noise transmission between rooms, and when used for floors, can reduce sound transference between levels as well.



## FIRE RESISTANT

Hebel is renowned for its fire resistant properties, and is a non-combustible building material. Hebel systems have been tested by the CSIRO and are proven to achieve Fire Resistance Levels (FRLs) of 60 minutes through to 240 minutes – as well as meeting or exceeding the requirements for all six Bushfire Attack Level (BAL) categories. This makes it an ideal choice in bushfire zones.



## PROVEN

CSR Hebel is the only manufacturer of AAC in Australia. With over 30 years of experience in developing, testing and producing AAC you can be assured you're getting high quality products and systems and unmatched technical expertise with Hebel. Hebel AAC includes a range of Australian made and imported product. Hebel imported products are manufactured on our behalf to Australian standards, and undergo the same rigorous quality testing.

# 1.1 DESIGNING AN EXTERNAL WALL USING HEBEL POWERPANEL<sup>XL</sup>

## DESIGN PROCESS

This section outlines the design process for determining the adequacy of Hebel PowerPanel<sup>XL</sup> panel.

- STEP 1** Determine the wind category, stud framing layout and panel height requirements.
- STEP 2** Design Criteria. Where required identify the National Construction Code (NCC) Performance Requirements:
  - Fire Resistance Level (FRL).
  - Sound insulation performance (R<sub>w</sub> values).
  - Energy efficiency (R-Value).
- STEP 3** The table below can be used to select a type, spacing and quantity of top hats and fixings to suit requirements.
- STEP 4** Select insulation and/or sarking material to suit energy efficiency and condensation requirements.
- STEP 5** Check adequacy of sound insulation and fire resistance level.
- STEP 6** Complete detailed design and documentation.

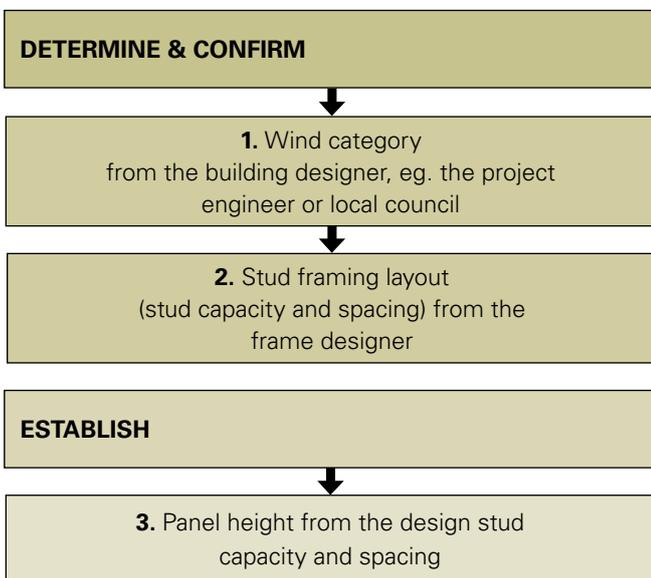


Table 1.1.1 Design process referencing

Determine	Table
No. of top hats	1.2.1 & 1.2.4
Max. stud spacing	1.2.1–1.2.5
No. of screws	1.2.2, 1.2.3 & 1.2.5
Corner effects	1.2.1–1.2.5
Control joint layout	Refer to control joints in construction details section

## COMPLIANCE WITH THE NATIONAL CONSTRUCTION CODE OF AUSTRALIA (NCC)

All building solutions such as walls, floors, ceilings, etc. must comply with the regulations outlined in the NCC or other authority.

The NCC is a performance based document, and is available in two volumes which align with two groups of ‘Class of Building’:

- Volume 1 – Class 2 to Class 9 Buildings; and
- Volume 2 – Class 1 & Class 10 Buildings – Housing Provisions.

Each volume presents Regulatory Performance Requirements for different Building Solutions for various classes of buildings and performance provisions.

These Performance Provisions include: Structure; Fire Resistance; Damp & Weatherproofing; Sound Transmission & Insulation; and Energy Efficiency.

This guide presents tables, charts and information necessary to assist in the design of a system incorporating Hebel PowerPanel<sup>XL</sup> that complies with the Performance Requirements of the NCC. The designer must check the adequacy of the building solution for Performance Requirements outlined by the appropriate authority.

## COMPLIANCE WITH AS 5146 REINFORCED AUTOCLAVED AERATED CONCRETE

All Hebel reinforced panel products conform with the Australian Standard for Reinforced Autoclaved Aerated Concrete (AAC), AS 5146.

The set of AS 5146 standards comprise of 3 parts:

- AS 5146 Part 1 – Structures
- AS 5146 Part 2 – Design
- AS 5146 Part 3 – Construction

These Standards are referenced in the Building Code of Australia making compliant AAC products Deemed-to-Satisfy (DTS) building materials.

AS 5146.3 – Construction, Section 4 contains details for 75mm reinforced AAC external walls in houses and low rise multi residential buildings, considered a DTS building system.

This provides the endorsement and confidence to regulatory and building certification bodies that the Hebel PowerPanel<sup>XL</sup> External Wall System is a NCC compliant construction system.

# 1.2 STRUCTURAL PROVISIONS

## OVERVIEW

The Hebel PowerPanel<sup>XL</sup> External Wall System consists of Hebel PowerPanel<sup>XL</sup> panels secured to the framing via horizontal steel top hats. This section provides the basic information on the selection of top hat spacings for a given stud spacing and wind category, as well as considerations to assist the designer in determining the appropriate wall configuration.

The design information presented in Tables 1.2.1 to 1.2.5 has been determined for 24mm and 35mm Hebel Perforated Top Hat section.

Minimum performance requirements for the metal studs, Hebel Perforated Top Hats, fixings and Hebel PowerPanel<sup>XL</sup> have been provided to assist the designer.

**IMPORTANT:** The design and approval of the structural framing (cold-formed steel or timber) is to be provided by the framing product manufacturer and/or project engineer.

## PRINCIPLES OF DESIGN

The principles on which the design is based include:

- a) The lateral wind loads applied to the panels are transferred into the horizontal top hats, then to the stud frame, which should be designed in accordance with the relevant Australian Standards for the imposed loads. The frame should be designed for all bracing and hold-down requirements.
- b) The design of the stud frame shall consider the weight of the suspended panels (such as the upper storey of two-storey construction).
- c) The system is not considered as cavity construction, as the Top Hat clearly bridges the cavity, hence the details show the necessity of sealing the windows and door frames, as well as applying a water resistant external coating.
- d) The system specifications vary with wind load. The notation used in AS 1684 Residential Timber Framed Construction has been adopted.
- e) The localised effects of wind around corners of buildings have been considered in the design and included in the tables. The extent of this effect is discussed towards the end of this section.

### Design Procedure

Design procedures for the verification of wall systems consisting of Hebel Autoclaved Aerated Concrete (AAC) PowerPanel<sup>XL</sup> panels generally follow the design principles outlined in Australian Standard AS 3600 – Concrete Structures for strength and serviceability design, with the exception of cover requirements for durability and development length for reinforcement.

The serviceability design of the Hebel PowerPanel<sup>XL</sup> panels has been carried out using the Transformed Section Theory, as detailed in the text book, 'Reinforced Concrete' by Warner, Rangan and Hall (Longman Cheshire). The load carrying capacity of the Hebel PowerPanel<sup>XL</sup> panels is influenced by several factors, such as:

- Imposed action (wind).
- Lateral stiffness of the supporting structure, lightweight structural, cold-formed steel framing.
  - Stud size and spacings.
  - Deflection limit.
- Height of the wall.
- Number and spacing of the top hats.
- Number of screw fixings considered effective.

### Criteria for corner panels

Due to the increase of wind load around the corners of buildings, extra top hats and screws may be necessary (N3 and greater) for a distance of 1200mm in each direction from the corner.

Tables 1.2.1 to 1.2.5 identify the installation criteria in these areas in the columns titled 'Panel Location – Corner'.

### Earthquake loads

Earthquake loading has not been considered in this design guide.

## DESIGN TABLES

This section presents tables to assist the designer in the selection of the number of top hats and number of screws for securing the Hebel PowerPanel<sup>XL</sup> panels to the framing for a given wind category.

### NOTES:

1. The wind category is to be used as a guide. The designer should check the project wind pressure against the values given in the tables.
2. Panels not tested for impact loading from windborne debris in Regions C and D as per AS1170.2. Building designer should allow for internal pressures resulting from dominant openings.

## STUD FRAME – STEEL OR TIMBER

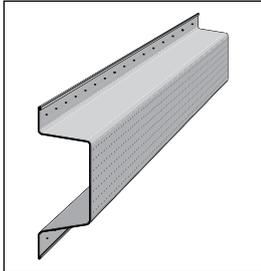
The stud frame shall be designed by the stud manufacturer or appropriate project engineer. Hebel PowerPanel<sup>XL</sup> panels are a steel reinforced AAC product and the support structure should be designed to provide sufficient stiffness.

The steel stud frame shall be designed and constructed in accordance with AS 3623 and AS/NZS 4600 (NCC Performance Requirement).

The timber stud frame shall be designed and constructed in accordance with AS 1684.

## HEBEL PERFORATED TOP HAT

Hebel Perforated Top Hats in galvanised steel are provided in nominal widths of 24mm and 35mm and have been designed and constructed in accordance with AS 3623 and AS/NZS 4600 (NCC Performance Requirement). The following tables are based on the 24mm and 35mm Hebel Perforated Top Hat section:



### 24mm Perforated Steel Top Hat section properties:

- Cold-formed perforated steel top hats
- Minimum thickness 0.42mm BMT
- Minimum yield strength 550MPa (zincalume)
- Coating class AZ150 (see Durability).

### 35mm Perforated Steel Top Hat section properties:

- Cold-formed perforated steel top hats
- Minimum thickness 0.55mm BMT
- Minimum yield strength 270MPa (Galvabond)
- Coating class Z275 (see Durability).

## PANELS SUPPORTED AT BASE

**Table 1.2.1 Number of top hats – panel supported at base (such as slab edge or shelf angle)**

Wind category	Ultimate wind pressure (kPa)		Stud spacing (mm)	Number of top hats per panel							
	Away from corners	Within 1200mm of corners		Panel length (mm)							
				≤ 2400		≤ 2700		≤ 3000		≤ 3300	
				Panel location		Panel location		Panel location		Panel location	
				Typical	Corner	Typical	Corner	Typical	Corner	Typical	Corner
N2	0.67/-0.62	-1.25	600	3	3	3	3	4	4	4	4
N3,C1	1.05/-0.98	-1.95	600	3	4	3	4	4	4*	4	5
N3,C1	1.05/-0.98	-1.95	450	3	3	3	3	4	4	4	4
N4,C2	1.56/-1.45	-2.90	450	3	4	3	5	4	5	4	6
N5,C3	2.30/-2.14	-4.27	450	4	5	5	5	5	6	5	6

\* One additional top hat is required when Hebel direct fix clips are used to support top hats.

#### NOTES:

1. Negative pressure indicates wind suction.
2. All top hats to be spaced evenly, with top and bottom top hats installed 250mm (maximum) from the end of the PowerPanel<sup>XL</sup>.
3. The bottom top hat may be installed 450mm from the bottom edge of the panel (distance measured from the centre of the top hat) for N2 and N3, C1 wind category, provided the amount of screws are installed as follows. 3 screws per top hat at typical panel locations and 4 screws per top hat at corner panel locations.
4. Additional top hats will be required below all window openings and above openings if a PowerPanel<sup>XL</sup> or sill block is to be installed in this location.
5. Corner panel location applies to a PowerPanel<sup>XL</sup> panel within 1200mm of corners.

**Table 1.2.2 Number of screws per panel at each top hat location – panel supported at base (such as slab edge or shelf angle)**

Wind category	Ultimate wind pressure (kPa)		Stud spacing (mm)	Number of screws per panel per top hat			
	Away from corners	Within 1200mm of corners		Panel location			
				Typical		Corner	
				Top hat location		Top hat location	
				Ends	Middle	Ends	Middle
N2	0.67/-0.62	-1.25	600	2	2	2	2
N3,C1	1.05/-0.98	-1.95	600	2	3	2	3
N3,C1	1.05/-0.98	-1.95	450	2	2	2	3
N4,C2	1.56/-1.45	-2.90	450	2	3	3	3
N5,C3	2.30/-2.14	-4.27	450	2	3	3	4

#### NOTES:

1. Type of screw used is 14-10x90mm hex head type 17 screw, fixed from outside the building.
2. Corner panel location applies to PowerPanel<sup>XL</sup> within 1200mm of corners.

# PANELS SUSPENDED FROM FRAME

**Table 1.2.3 Number of screws per panel at each top hat location – panel suspended at gable ends**

Wind category	Ultimate wind pressure (kPa)		Stud spacing (mm)	Number of screws per panel per top hat		Maximum spacing of top hat (mm)	
	Away from corners	Within 1200mm of corners		Panel location		Panel location	
				Typical	Corner	Typical	Corner
N2	0.67/-0.62	-1.25	600	2	3	800	750
N3,C1	1.05/-0.98	-1.95	600	3	4	800	600
N3,C1	1.05/-0.98	-1.95	450	3	4	800	650
N4,C2	1.56/-1.45	-2.90	450	4	4	800	450
N5,C3	2.30/-2.14	-4.27	450	4	4	600	350

**NOTES:**

1. Top and bottom top hats installed 250mm (maximum) from the end of the PowerPanel<sup>XL</sup> panel.
2. Top hats to be installed horizontally with panels to span vertically. Number of screws per panel per top hat information is not suitable for soffits or any other areas where the panel is not vertical.
3. Corner panel location applies to PowerPanel<sup>XL</sup> panels within 1200mm of corners.
4. Type of screw used is 14-10x90mm hex head type 17 screw, fixed from outside the building.

**Table 1.2.4 Number of top hats – panel suspended from framing (e.g second storey construction)**

Wind category	Ultimate wind pressure (kPa)		Stud spacing (mm)	Number of top hats per panel							
	Away from corners	Within 1200mm of corners		Panel length (mm)							
				≤ 2400		≤ 2700		≤ 3000		≤ 3300	
				Panel location		Panel location		Panel location		Panel location	
Typical	Corner	Typical	Corner	Typical	Corner	Typical	Corner				
N2	0.67/-0.62	-1.25	600	4	4	4	4	4	4	4	4
N3,C1	1.05/-0.98	-1.95	600	4	4	4	4	4	4	4	4*
N3,C1	1.05/-0.98	-1.95	450	4	4	4	4	4	4	4	4
N4,C2	1.56/-1.45	-2.90	450	4	4	4	4*	4	5	4	5*
N5,C3	2.30/-2.14	-4.27	450	4	5	5	6	5	6	5	6

\* One additional top hat is required when Hebel direct fix clips are used to support top hats.

**NOTES:**

1. Negative pressure indicates wind suction.
2. All top hats to be spaced evenly, with top and bottom top hats installed 250mm (maximum) from the end of the PowerPanel<sup>XL</sup> panel.
3. Additional top hats will be required below all window openings and above openings if a panel or sill block is to be installed in this location.
4. Corner panel location applies to PowerPanel<sup>XL</sup> panels within 1200mm of corners.

**Table 1.2.5 Number of screws per panel at each top hat location – panel suspended from framing (e.g second storey construction)**

Wind category	Ultimate wind pressure (kPa)		Stud spacing (mm)	Number of screws per panel per top hat			
	Away from corners	Within 1200mm of corners		Panel location			
				Typical		Corner	
				Top hat location		Top hat location	
Ends	Middle	Ends	Middle				
N2	0.67/-0.62	-1.25	600	2	2	2	3
N3,C1	1.05/-0.98	-1.95	600	2	3	3	4
N3,C1	1.05/-0.98	-1.95	450	2	3	3	4
N4,C2	1.56/-1.45	-2.90	450	2	4	3	4
N5,C3	2.30/-2.14	-4.27	450	2	4	4	4

**NOTES:**

1. Type of screw used is 14-10x90mm hex head type 17 screw, fixed from outside the building.
2. Corner panel location applies to PowerPanel<sup>XL</sup> panels within 1200mm of corners.

# PANELS FIXED TO DROP EDGE BEAM

**Table 1.2.6 Number of top hats per panel - drop edge beam fixing**

Wind category	Ultimate wind pressure (kPa)		Fixing spacing of top hat to concrete (mm)	Max. top hat spacing							
	Away from corners	Within 1200mm of corners		Panel length (mm)							
				≤ 2400		≤ 2700		≤ 3000		≤ 3300	
				Panel location		Panel location		Panel location		Panel location	
				Typical	Corner	Typical	Corner	Typical	Corner	Typical	Corner
N2	0.67/-0.62	-1.25	600	900	600	900	600	900	600	900	600
N3, C1	1.05/-0.98	-1.95	600	900	600	900	600	900	450	900	600
N3, C1	1.05/-0.98	-1.95	450	900	450	900	450	900	450	900	450
N4, C2	1.56/-1.45	-2.9	450	600	450	600	450	600	450	600	450
N5, C3	2.30/-2.14	-4.27	450	450	300	450	300	450	300	450	300

**NOTES:**

1. Top and bottom top hats installed 250mm (maximum) from the end of the PowerPanel<sup>XL</sup> panel.
2. Maximum end overhang of top hat to be 150mm.
3. Minimum concrete grade is 25MPa.
4. Corner panel location applies to PowerPanel<sup>XL</sup> panels within 1200mm of corners.
5. Ramset Ramplug DNP08 to be used to fix the top hats to the concrete drop edge beam. Screw selection and installation of fixings must be in accordance to manufacturer's requirements.
6. At each fixing point, two anchors are required. Minimum anchor spacing and minimum concrete edge distance to be 50mm.
7. Screws to fix panel to top hat to be in accordance to table 1.2.2.

## FIXINGS

Table 1.2.7 outlines the connection type and requirements for constructing Hebel PowerPanel<sup>XL</sup> detailed in this design guide.

NOTE: From Table 1.2.7, 14-10x90mm hex head type 17 screws are specified and recommended for fixing the PowerPanel<sup>XL</sup> panel to top hat sections from the outside of the building. Refer to Hebel Technical Update TU-017 where bugle head screws are desired to be used in lieu of the 14-10x90mm hex head type 17 screws for this connection.

The project engineer or framing manufacturer is responsible for specification of alternative details. The minimum performance requirement of the screw is:

- Minimum screw coating class in accordance with AS 3566: Class 3 (Refer Section 2.1 for Durability).

### Zero boundary wall installation

Where access is limited or unavailable for fixing the PowerPanel<sup>XL</sup> panel to the top hat section from the outside of the building, such as in zero boundary wall installations, then fixing of the panel from the inside of the building using 14-10x65mm hex head type 17 screws is permitted on the basis that one additional screw (to the number of screws noted in Tables 1.2.2, 1.2.3 & 1.2.5 is provided per panel per top hat connection. For more details refer to Figure 3.6.4.2 and Hebel Technical Update TU-018.

**Table 1.2.7 Screws types**

Type of screw	Application	Socket type
12-11x35mm hex head type 17 screw	Fix top hat to timber frame	5/16" hex mag. socket
10-16x16mm hex head self drilling screw	Fix top hat to steel stud frame (1.2mm BMT max.)	5/16" hex mag. socket
14-10x65mm hex head type 17 screw	Fix PowerPanel <sup>XL</sup> to top hat from inside of building (zero boundary application only)	3/8" hex mag. socket
14-10x90mm hex head type 17 screw*	Fix PowerPanel <sup>XL</sup> to top hat from outside of building	3/8" hex mag. socket

\* The screws fixing the PowerPanel<sup>XL</sup> panels to top hats are countersunk min. 5mm into the panel and filled with Hebel Adhesive

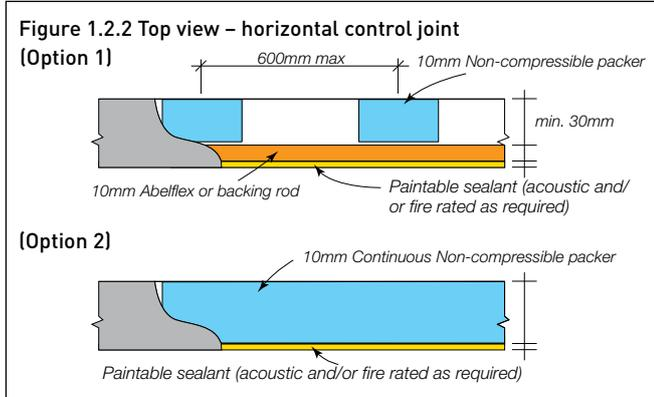
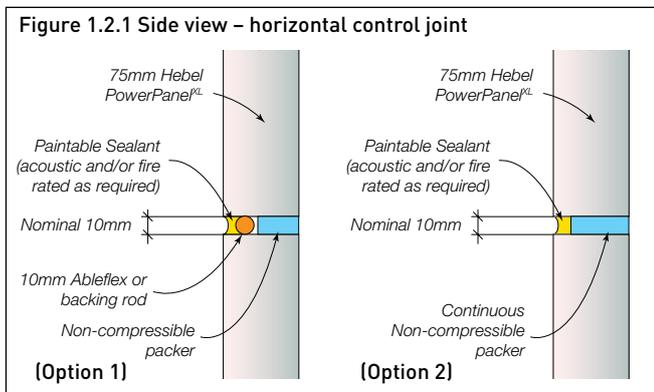
## STRUCTURAL FRAMING DESIGN

The use of Hebel PowerPanel<sup>XL</sup> in two-storey construction involves a number of design issues that require attention. In conjunction with the following, refer to the Construction Details in Section 3.6.

NOTE: When PowerPanel<sup>XL</sup> panels are suspended from the stud frame the project engineer shall design the frame to support the weight of the PowerPanel<sup>XL</sup> panels.

### Steel joists or engineered timber joists (≤1% shrinkage)

Lower storey panels are to bear on the slab edge. However, consideration should be given to the sectional size of the lintels over openings on the lower storey. As the details reveal, only a dummy control joint (nominal 10mm packers, backing rod and an external grade acoustic and/or fire rated paintable sealant joint) is required at the horizontal PowerPanel<sup>XL</sup> junction between the upper and lower panels. The panel support packer should consist of a durable material that will not degrade during the life of the structure.



NOTE: Use 10mm wide by 16mm deep CSR Fireseal or Fireblock XT Sealant at vertical and horizontal control joints to achieve FRL of -/120/120 for the wall system. See Section 2.2. Protect CSR Fireseal Sealant from rain until sealant has developed a thick skin. Once cured, CSR Fireseal should be painted over with a compatible external grade acrylic coating i.e. Dulux AcraTex or similar.

### Timber frame construction (>1% shrinkage joist).

Movements in the order of 25mm can occur in a two storey timber frame with a timber first floor. The fixing method used in the Hebel PowerPanel<sup>XL</sup> External Wall System does not allow for this extent of differential movement between the external skin and the timber frame.

The allowances for shrinkage of timber framing in NCC Vol. 2, by providing gaps between framing and masonry, should be adopted as a minimum.

It is therefore recommended that the upper storey PowerPanel<sup>XL</sup> panels be installed 35mm clear of the lower storey panels. During construction a temporary packer can be used to separate the panels and is then removed after the panels have been fixed. An architectural trim (feature moulding) must be used to hide the horizontal control joint. Contact Hebel Technical Services for further details.

The impact of this construction is to load the lower storey frame with the weight of the upper storey panels. In effect, an extra 44kg/m<sup>2</sup> (for the weight of the upper panels) is being added to the load already carried by the timber frame. The load approximates 1.05kN/m (2.4m wall height).

To simplify the design implications of this extra load, it is recommended to add an extra 1.4m of tributary width for a 90kg/m<sup>2</sup> tile roof load (for 2.4m upper wall heights) for the design of the lower storey frame and timber lintels, when using AS 1684. – cyclonic or non-cyclonic areas.

NOTE: Additional considerations should be undertaken for installation of the Hebel PowerPanel<sup>XL</sup> External Wall System onto copper treated timber including wall framing treated with CCA (Copper Chrome Arsenic). Contact Hebel Technical Services for more information.

### Bracing of the building

The walls of the dwelling should be braced using steel cross bracing wherever possible to allow the fixing of the PowerPanel<sup>XL</sup> panels without the need for additional packing. Ply or sheet bracing should be used on the external wall if the walls are too short for the steel cross bracing (refer AS 1684 – cyclonic or non-cyclonic areas). In this case, the full length of the wall should be sheeted to prevent misalignment of the panels.

Alternatively, localised strips of the sheeting can be fixed to the intermediate studs between the areas of full sheet bracing to maintain the panel alignment. All fixing is only from the outside, except on zero boundary walls. The extent of the bracing should be determined by the frame designer or project engineer.

NOTE: Minimum screw embedment depth into timber frame must be 25mm.

Table 1.2.8 Comparative wall thicknesses (mm)

Wall system	Wall element width			Total width
	Stud	Cavity	Masonry leaf	
Brick veneer	70	40	110	220
Hebel PowerPanel <sup>XL</sup>	70	24 – 35*	75	169 – 180*
Brick veneer	90	40	110	240
Hebel PowerPanel <sup>XL</sup>	90	24 – 35*	75	189 – 200*

\* NOTE: Depending on top hat selection

# 1.3 DESIGN & DETAILING CONSIDERATIONS

## BUILDING SETOUT

The Hebel PowerPanel<sup>XL</sup> External Wall System is principally designed for modular construction. The full benefit of savings in time and cost will be fully realised when the construction is designed to suit a 300mm module. In principle, thoughtful setout on the drawing board will minimise the site-cutting of the panels, which is time consuming and wasteful compared to the installation of stock PowerPanel<sup>XL</sup> panels.

### External wall height

Typically the external wall height is the distance from the base of the slab step down up to 50mm above the height of the eaves lining.

Window and door heights should also be considered when determining panel layout. Typically a 300mm distance below or above door or window heights is desirable.

### Wall length (horizontal dimensions)

Although not as critical as the wall height, the wall length designed to 300mm dimensions will help reduce waste.

## TERMITES

It is the builder's responsibility to ensure that all council and NCC requirements are fully adhered to in regard to the design of the house for preventing termite attack. The construction details contained in this guide do not attempt to fully address the issues due to the variation of requirements from state to state. Hebel PowerPanel<sup>XL</sup> is ideally suited to the exposed edge method of perimeter protection. NCC Vol. 2 deals with termite risk management and the reference code is AS 3660.

## FOOTINGS

Footings for Hebel PowerPanel<sup>XL</sup> should comply with articulated masonry veneer construction as specified in Australian Standard AS 2870. This is a minimum requirement. Local engineering advice should always be sought, especially in areas of highly reactive ground conditions.

## MOVEMENT CONTROL JOINTS

During the life cycle of a building, the building and the materials that it is constructed from will move. These movements are due to many factors working together or individually, such as support structure movement (lateral sway or vertical deflection), thermal expansion and contraction and differential movements between materials. This movement, unless relieved or accommodated for, will

induce stress in the materials, which may be relieved in the form of cracking. To accommodate these movements and relieve any induced stresses, which could potentially crack the wall, movement joints need to be installed.

- Control joints are provided to relieve the induced stresses resulting from thermal expansion or contraction of the AAC, or differential movement between the AAC and another material or structure, such as abutting walls or columns of concrete or brickwork. Control joints can delineate coating shrinkage breaks.

Vertical control joints should coincide with control joints in the supporting structure and anywhere that significant structural movement is expected, where the wall abuts a vertical structure, such as an existing building, or adjacent to large openings. Refer to control joints in **construction details section**.

Table 1.3.1 Spacing of vertical control joint based on site classification

Site Class	Vertical control joint spacing
A, S	6
M, M - D	5.5
H1, H1 - D	5
H2, H2 - D	4.5

Notes:

1. Refer to AS2870 for guidance on the site classification.
2. Where building on a site with a class P identification, advice should be sought from a structural engineer. Sites identified as class P can relate to a single or number of soil conditions that may affect the behaviour of the slab (i.e. mine subsidence, varying depths of fill, abnormal moisture conditions etc.) As such, the project structural engineer would normally design the slab according to these site specific features and upon advice from a geotechnical report. From this assessment the engineer can then relate the soil type back to class A, S, M or H type soils based on the extent of settlement/heave (particularly in clay type soils). The spacing of control joints required in the external walls can then be determined based on Table 1.3.1, above.  
Note: The location of control joints for class E sites should be determined by engineering principles and specified by the project structural engineer.

Important: Where installing Hebel external wall claddings on slab edge rebates for sites that contain saline soils, a clearance between the base of the panel and the finished ground level must be maintained to avoid contact of the panels with these soils. Where the slab edge rebate is rendered, it must be ensured that the DPC under the panel is cut flush with the external face of the panel to form a barrier between the slab edge rebate and the underside of the overhanging section of panel to prevent the rise of salts (from saline soils) through the slab edge render and into the panel.

This guide proposes minimum widths for the movement joints. The project engineer shall determine if the joints are sufficient to accommodate the movement of the specific project building. Typically, the vertical joint is nominally 10mm wide and filled with an appropriate backing rod and flexible sealant.

NOTE: At all control joints, the top hat should be discontinuous to allow for the effective movement of the building at these locations.

A horizontal control joint is required beneath slabs or angles to accommodate any expected deflection. The magnitude of the deflection must be verified by the building designer. Typically, the horizontal joint is nominally 10mm wide and filled with an appropriate external grade acoustic and / or fire rated paintable sealant. External aluminium render beads can be used as an option at horizontal control joints providing neat and consistent finished joints (Refer to Section 3.4).

## CONDENSATION

Condensation is a complex problem and can occur under a variety of conditions, not just cold conditions. Literature on this subject is available from CSIRO/BRANZ/ASHRAE and must be consulted when building in areas where condensation is likely to occur.

In these cases, the appropriate use of a sarking as a vapor barrier or as thermal insulation, or both, can be effective in controlling condensation.

## PENETRATIONS

Small service penetrations through the panel should allow for differential movement between the panel and the service. All penetrations are a potential source for water ingress and should be sealed with an appropriate acoustic and/or fire rated paintable sealant.

## WINDOWS

The builder should also ensure that the reveal size is correct to suit PowerPanel<sup>XL</sup>. Refer to Table 1.3.1 for recommendations.

The sizes below typically apply to aluminium framed windows. If timber windows are being used similar tolerances and guidelines apply.

Table 1.3.2 Reveal size

Stud size 70mm	
Top hat size	Reveal size**
24mm	100mm*
35mm	115mm
Stud size 90mm	
Top hat size	Reveal size**
24mm	120mm
35mm	135mm

\*Reveal sizes may vary from one manufacturer to another.

\*\*Figures shown assume brace board is used on framework.

NOTE: The external sealant in the control joints adjacent to windows must be retuned to the window frame, and sealant installed along the window head, sill and junction of the sides of the window to the panel. No gap should exist between the external sealant and the window frame.

## SUPPLEMENTARY CLADDING

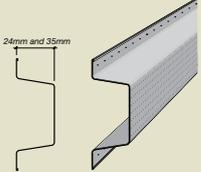
Supplementary cladding systems such as weatherboards and lightweight fibre cement may be installed over the top of the Hebel PowerPanel<sup>XL</sup> External Wall System. For more details please contact Hebel Technical services.



Photo courtesy of Danette Architecture.

# 1.4 SYSTEM COMPONENTS

The PowerPanel<sup>XL</sup> External Wall System is a complete system and Hebel stocks many of the products and materials required for your convenience.

Product	Description	Supplied by CSR Hebel																												
Hebel PowerPanel <sup>XL</sup>	<p>The core component of the Hebel PowerPanel<sup>XL</sup> External Wall System is the 75mm thick Hebel PowerPanel<sup>XL</sup> panel. The panel is manufactured in a range of stock sizes as detailed below:</p> <table border="1"> <thead> <tr> <th colspan="3">Panel weight (kg)</th> </tr> <tr> <th>Length (mm)</th> <th>Width (mm)</th> <th>Weight (kg) at 35% M.C.</th> </tr> </thead> <tbody> <tr> <td>2400</td> <td>600</td> <td>58</td> </tr> <tr> <td>2550</td> <td>600</td> <td>62</td> </tr> <tr> <td>2700</td> <td>600</td> <td>66</td> </tr> <tr> <td>2800</td> <td>600</td> <td>68</td> </tr> <tr> <td>2850</td> <td>600</td> <td>69</td> </tr> <tr> <td>3000</td> <td>600</td> <td>73</td> </tr> <tr> <td>3300</td> <td>600</td> <td>80</td> </tr> </tbody> </table> <p>NOTE: 75mm PowerPanel 1200 x 600mm weight 37kg. 75mm PowerPanel 1800 x 600mm weight 56kg.</p>	Panel weight (kg)			Length (mm)	Width (mm)	Weight (kg) at 35% M.C.	2400	600	58	2550	600	62	2700	600	66	2800	600	68	2850	600	69	3000	600	73	3300	600	80	✓	
Panel weight (kg)																														
Length (mm)	Width (mm)	Weight (kg) at 35% M.C.																												
2400	600	58																												
2550	600	62																												
2700	600	66																												
2800	600	68																												
2850	600	69																												
3000	600	73																												
3300	600	80																												
Top Hat	<p>Hebel Perforated Top Hats are used to fix the Hebel PowerPanel<sup>XL</sup> panel to the structural support framing. There are two nominal widths available: 24mm and 35mm – incorporating perforated flanges for ease of installation on to external wall frame.</p>	✓																												
Fasteners & Fixings	<p>Fixing of top hat to timber stud frame; 12-11x35mm hex head type 17 screw.</p>	✓																												
	<p>Fixing of top hat to steel framing; 10-16x16mm hex head self drilling screw.</p>	✓																												
	<p>Fixing of Hebel PowerPanel<sup>XL</sup> panels to top hat from inside of buildings 14-10x65mm hex head type 17 screw (zero boundary walls only). Refer to Table 1.2.7.</p>	✓																												
	<p>Fixing of Hebel PowerPanel<sup>XL</sup> panels to top hat 14-10x90mm hex head type 17 screw.</p>	✓																												
Hebel Direct Fixing Clip	<p>For attaching top hat to structural stud frame (zero boundary application only).</p>	✓																												

Product	Description	Supplied by CSR Hebel	
Hebel Mortar	Hebel Mortar (supplied in 20kg bags) when required is used as a thick bed mortar base to provide a level base for PowerPanel <sup>XL</sup> installation as well as providing acoustic and fire protection at the base of the panels.	✓	
Hebel Adhesive	Hebel Adhesive (supplied in 20kg bags) is used for gluing the PowerPanel <sup>XL</sup> panels together at vertical and horizontal joints.	✓	
Hebel Patch	Minor chips or damage to PowerPanel <sup>XL</sup> panels are to be repaired using Hebel Patch (supplied in 10kg bags).	✓	
Hebel Anti-Corrosion Protection Paint	To coat exposed reinforcement during cutting.	✓	
Hebel Base Sealer	For use when sealing the base of Hebel panels that may come into contact with soil levels (supplied in 5L tubs)	✓	
Hebel External Aluminium Render Bead (Optional)	Hebel External Aluminium Render Bead is used to provide neat and consistent horizontal control joints.	✓	

NOTE: CSR has engineered and tested the PowerPanel<sup>XL</sup> External Wall System to comply with the NCC and relevant Australian Standards. It cannot guarantee products and accessories not specified by CSR will perform to these standards. The Product Guarantee will only apply if all components used in the system are specified by CSR.

# 2.1 DURABILITY

## OVERVIEW

Durability means the capability of a building or its parts to perform a function over a specified period of time. It is not an inherent property of a material or component. It is the outcome of complex interactions among a number of factors, including:

- The service conditions
- Material characteristics
- Design and detailing
- Workmanship
- Maintenance

(‘ABCB Guideline Document – Durability in buildings: 2003’)

The following sub-sections of the durability topic are written in order to provide general guidelines on how best to provide, enhance and maintain adequate durability of Hebel PowerPanel<sup>XL</sup> panels.

## MAINTENANCE & ENHANCEMENT OF DURABILITY

The durability of the Hebel PowerPanel<sup>XL</sup> External Wall System can be enhanced by periodic inspection and maintenance. Inspections should include examination of the coatings, flashings and sealants. Paint finishes must be maintained in accordance with the manufacturer’s recommendations. Any cracked and damaged finish or sealants, which would allow water ingress, must be repaired immediately by recoating or resealing the effected area. Any damaged flashings or panels must be replaced as for new work.

The durability of the system can also be increased by using Class 4 fixings throughout, additional treatment of steelwork, and by painting all exposed sealants to the sealant manufacturer’s recommendations.

## COASTAL AREAS

Hebel PowerPanel<sup>XL</sup> panels can be used in coastal areas with additional precautions to ensure salt does not build up on the surface of the wall. For buildings up to 1000 metres from a shoreline or large expanse of salt water the following is required:

- All horizontal and vertical movement joints must be appropriately caulked; and
- All walls must be sufficiently exposed from above so that rain can perform natural wash-down of the wall; or
- Walls which are protected by soffits above must be washed down twice per year to remove salt and debris build-up particularly at the joints; and
- In all cases, Class 3 screws must be used.

NOTE: Class 3 screws must be countersunk in outer face of the PowerPanel<sup>XL</sup> by at least 5mm and filled with Hebel Adhesive.

## HEBEL CLADDING WHERE INSTALLED IN FLOOD AFFECTED AREAS

Hebel panels are an autoclaved aerated concrete (AAC) material containing macropores (i.e the air voids in the Hebel material structure) that create a porous structure. The panels are coated with an acrylic coating system generally comprising a base skim coat, texture coat and final coat layer to prevent the ingress of water from inclement weather.

Should Hebel external walls be subject to inundation by flood waters, this will likely affect and possibly breach the integrity of the external coatings and sealants causing the panels to absorb moisture. Although the mineral properties of the Hebel AAC material structure are generally unaffected by moisture, the integrity of the panels must be re-assessed following a flood event, by removal of the external coatings. It is likely that extended periods of inundation could cause long-term damage to the durability of panels (i.e manifested corrosion of reinforcement, damage from impact caused by flood debris etc), in which case, the affected panels should be removed and replaced.

For these reasons, best building practice would be to ensure that the base of panels remain within the freeboard region of the determined and site-specific flood level to avoid inundation, as Hebel AAC panel product warranties following exposure to a flood event are not guaranteed and are subject to the discretion of CSR Hebel.

## HEBEL POWERPANEL<sup>XL</sup>

Hebel PowerPanel<sup>XL</sup> has many characteristics which make it a very durable product, including:

- Will not rot or burn
- Is not a food source for termites
- Unaffected by sunlight
- Not adversely affected over normal temperature ranges
- One quarter the weight of conventional concrete
- Solid and strong with corrosion protection coated steel reinforcement.

## DURABILITY OF COMPONENTS

It is the responsibility of the building designer to ensure that the components such as screws, top hat battens and other steel components have the appropriate corrosion protection to be able to maintain their strength and integrity to suit the required design life of the project.

**IMPORTANT:** Termite treated timber frames (such as LOSP treated frames) may require sarking to prevent corrosion of steel components. Please refer to frame manufacturer for compatibility. CCA treated pine frames have a deleterious effect on the top hat coatings, which can lead to corrosion. Where timber is CCA treated, provide a barrier between top hat and timber member. Refer to frame manufacture for compliance with the frames compatibility with steel top hats and screw fixings.

When assessing durability the following documents can be referred to for guidance:

- ABCB Guideline Document – Durability in buildings: 2003.
- AS/NZS 2312: 2002 – Guide to the protection of structural steel against atmospheric corrosion by the use of protective coatings.
- ISO 9223: 1992 – Corrosion of metals and alloys – Corrosivity of atmospheres – Classification.
- AS 3566: 2002 – Self drilling screws for the building and construction industries.
- AS 2331 Series.

Reference to AS 3566 should always be adhered to when selecting the screw's corrosion resistance classification.

## WALL FRAMES

### Steel frames

The designer needs to ensure that the steelwork and Hebel AAC products have adequate protective systems to ensure that durability is maintained. The durability of the stud frame can be enhanced by the provision of a membrane such as sarking. The manufacturer of the steel stud frame can provide guidance on the appropriateness of this solution on a project-by-project basis.

**IMPORTANT:** The steel frame requirements outlined in the BCA Vol. 2, Part 3.4.2 should be considered in conjunction with steel frame design and construction advice from the steel frame manufacturer. These requirements consist of minimum protective surface coatings with restrictions on the location of the building and exposure condition of the steel frame.

### Timber frames

Information on the durability design of timber structures and components can be obtained from documents such as:

- AS 1720.1 Timber Structures, Part 1: Design Methods
- AS 1684 Timber Framing Code
- State timber framing manuals
- AS 3660 Subterranean Termites.



Photo courtesy of Metricon Homes

# 2.2 FIRE RESISTANCE PERFORMANCE

## OVERVIEW

The Hebel PowerPanel<sup>XL</sup> External Wall System can be subjected to a fire loading as the result of either an external fire source, or an internal fire source. When the wall requires a fire resistance level (FRL) rating, Hebel provides the following guidance:

### External fire source

For an external fire source, the excellent fire resistance qualities of the Hebel PowerPanel<sup>XL</sup> External Wall System protects the structural support framing and provides a high fire resistance level.

NOTE: The FRL rating of the wall can be affected by the penetrations and the method adopted to protect these penetrations. A fire collar with a –/60/60 FRL rating will govern the FRL of the wall, even if the wall configuration has a FRL rating of –/90/90. Where required, the performance of the external coating when subjected to a fire loading shall meet the appropriate performance requirements outlined in the NCC. Joints and gaps need to be appropriately fire rated, e.g. vertical control joint will need fire rated sealant and horizontal joints must be blocked with compressible fire rated material.

### Fire certificates and reports

Copies of the test reports and/or opinions can be obtained by contacting Hebel Technical Services. The Hebel PowerPanel<sup>XL</sup> External Wall System achieves a FRL of up to 180/180/180 minutes up to a maximum wall height limit of 3300mm per level. (CSIRO assessment report FCO-3003)

Only figures 3.6.4.1, 3.6.4.2, 3.6.4.4, 3.6.5.7, 3.6.6.5, 3.6.6.7, 3.6.6.8, 3.6.7.1, 3.6.7.2, 3.6.7.5, 3.6.7.9 and 3.6.7.10 in section 3.6 achieve a fire performance. Where other details are required to provide a fire performance or where a greater Fire Rating Level (FRL) is required, then assessment by a qualified fire engineer is necessary to verify such performance.

### Internal fire source

For an internal fire source the studs must be protected by the internal wall linings. The protective lining system can consist of CSR Gyprock Fyrchek<sup>TM</sup> plasterboard fixed to the support framing. The Hebel PowerPanel<sup>XL</sup> External Wall System can achieve an internal and external (two way) FRL of up to 120/120/120. For more details please contact Hebel Technical services.

### External walls in fire – NCC Provisions

Where necessary the designer and builder should ensure the structural support framing, its connections and the Hebel PowerPanel<sup>XL</sup> installation are satisfactory when subjected to fire conditions. The NCC Vol 2 outlines provisions for external walls for fire resistance in a residential building where the external wall is less than 900mm from an allotment boundary or 1.8m from another building on the same allotment. If this occurs an FRL of not less than 60/60/60 is required from the outside.

## FIRE PERFORMANCE OF HEBEL POWERPANEL<sup>XL</sup>

The Hebel PowerPanel<sup>XL</sup> External Wall System has been assessed by CSIRO to achieve a Fire Resistance Level (FRL) of up to 180/180/180. Note, the fire source is considered on the PowerPanel<sup>XL</sup> side. This enables Hebel PowerPanel<sup>XL</sup> to be used in the following applications:

- Walls on zero line allotment blocks.
- Multi-storey residential dwellings – external walls.

NOTE: In the above applications, each PowerPanel<sup>XL</sup> panel should be screwed as specified in this guide, except a minimum of three screws should be installed through the middle top hat into each PowerPanel<sup>XL</sup> panel.

## DESIGN CONSIDERATIONS

### Fire stop penetrations

Penetrations through Hebel PowerPanel<sup>XL</sup> to accommodate pipework, electrical cabling or ductwork will have to be protected (fire stop), to prevent the spread of fire through the penetration. The penetration can be protected with proprietary products such as:

- Fire rated sealants.
- Fire collars and intumescent wraps.
- Fire rated mortars.
- Fire rated pillows.
- Fire rated switch boxes.

Hebel recommends contacting the manufacturer to obtain the appropriate product/solution and installation method for the application and wall configuration.

## BUSHFIRE ZONE REQUIREMENTS

The Hebel PowerPanel<sup>XL</sup> External Wall System can achieve the construction requirements up to BAL - FZ as specified in Australian Standard AS 3959. When constructing in BAL - FZ a minimum setback distance of 10m from the edge of the classified vegetation is required. It is the responsibility of the building designer to ensure compliance to AS 3959 is achieved in accordance with clause NCC 2022 Vol. 2 H7F4 (F2.7.4 of NCC 2019 Volume 2).

## 2.3 ENERGY EFFICIENCY

### NATIONAL CONSTRUCTION CODE (NCC)

The NCC is available in two volumes which align with two groups of 'Class of Building':

- Volume 1 – Class 2 to Class 9 Buildings; and
- Volume 2 – Class 1 & Class 10 Buildings – Housing Provisions.

Each volume presents the Performance Requirements for the efficient use of energy for internal heating and cooling in buildings. The majority of changes have been associated with the Housing Provisions.

The Performance Requirements for energy efficiency ratings are dependent upon the form of construction (i.e. walls or floors), Class of Building, and the type of areas being separated. The performance requirement is a value that is the Total R-Value, which is the cumulative total of the individual R-Values of the building system components.

### THE HEBEL POWERPANEL<sup>XL</sup> EXTERNAL WALL SYSTEM

One of the primary design objectives in planning a building is to provide a cost effective comfortable living / working environment for the building's inhabitants. Exploiting the inherent thermal mass and insulation qualities of Hebel enables the designer to achieve this objective.

Several international comparative studies have been conducted to investigate the benefits of incorporating AAC walls in place of conventional wall systems. A common trend was the lower heating and cooling energy consumption and smaller mechanical equipment required to maintain a comfortable living environment, especially with regards to regions of mainly cold weather. The excellent performance was the result of the three characteristics – thermal mass, thermal insulation and the air tightness of the construction.

The level of insulation provided in a wall is determined by the required Total R-Value. The higher the required Total R-Value the greater the insulation provided. Hebel PowerPanel<sup>XL</sup> External Wall System incorporating CSR Bradford insulation can provide the R-Value ratings outlined in Tables 2.3.4 and 2.3.5.

### THERMAL INSULATION

It is recommended that insulation materials be installed to enhance thermal insulation properties and occupant comfort. Insulation also improves the acoustic performance of the wall against outside noise.

The NCC provides Deemed-to-Satisfy Provisions for compliance and installation of the various types of insulation. The insulation should be installed with Hebel PowerPanel<sup>XL</sup> such that it forms a continuous barrier to contribute to the thermal barrier. All insulation installed in Hebel PowerPanel<sup>XL</sup> External Wall systems must comply with: AS/NZS 4859.1; or AS 2464.3 for loose fill insulation.

### AIR TIGHTNESS

The thermal performance can be influenced by many factors. Most of these are related to the design decisions and properties of the adopted materials. Construction practices can also significantly affect the performance with poor sealing, resulting in drafts. The tight construction tolerances of AAC provide a wall with low air infiltration rate. Testing at the CSIRO (Test Report DTM327) on Hebel blockwork with thin bed adhesive joints has determined an air infiltration rate of 0.3L/s (0.014% of internal volume). For PowerPanel<sup>XL</sup> panels having fewer thin bed adhesive joints, a rate less than this could be achieved.

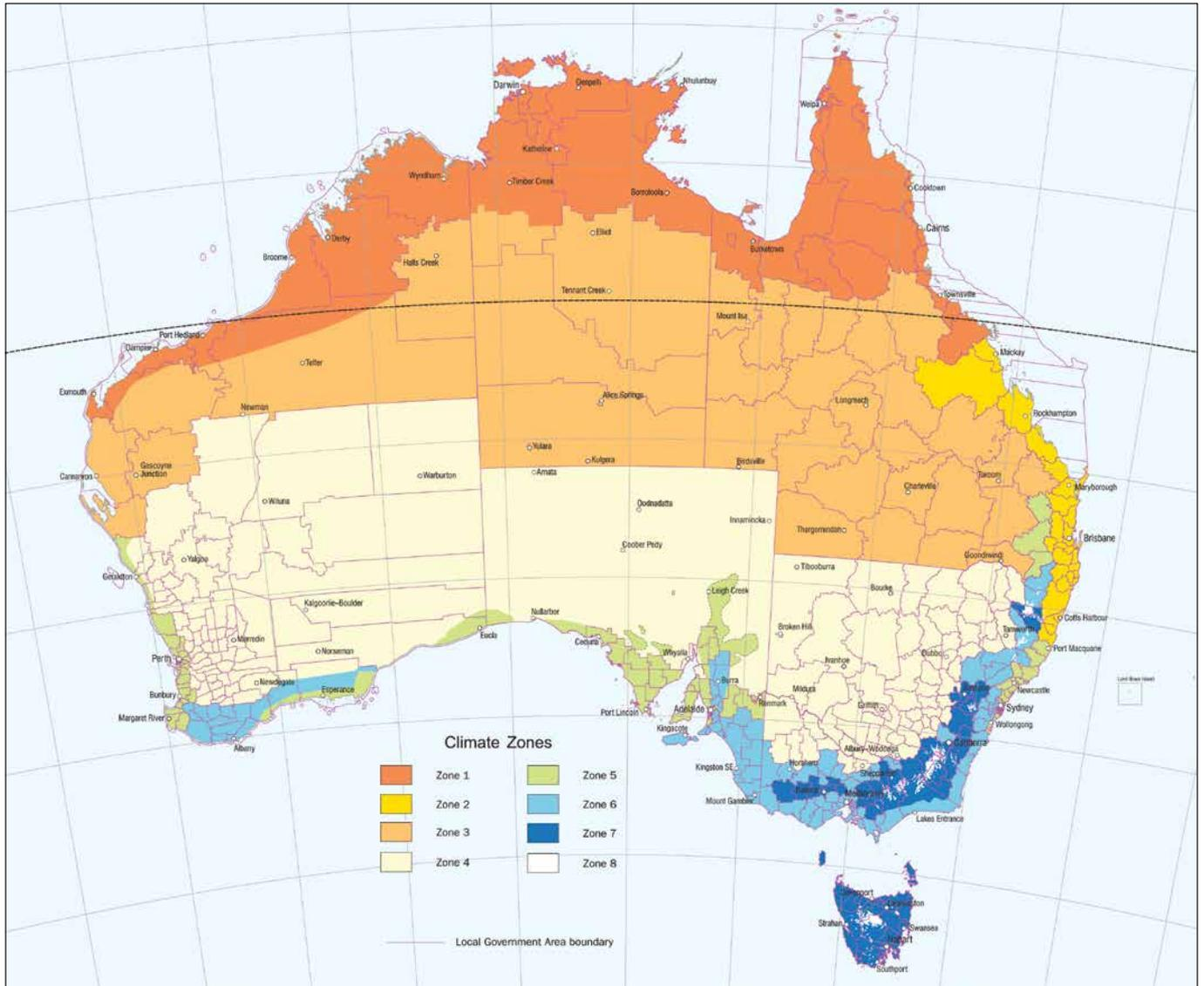
### SARKING

As well as controlling condensation and acting as an air barrier, sarking can be used to significantly improve the thermal insulation and energy efficiency performance of a building solution. Sarking layers can alter the performance of the cavity by providing a reflection side. The design of the sarking arrangement is complex and should be performed by the appropriate project consultant.

Where the sarking layer provides a weatherproofing function, the sarking material must comply with AS/NZS 4200 Parts 1 and 2.

The following tables show the performance levels required for walls and floors under the NCC and the thermal performance of the Hebel PowerPanelXL External Wall System.

Figure 2.3.1 Climate zones for thermal design



- STEP 1** Determine which climate zone your project is located in Australia from the map.
- STEP 2** From Table 2.3.1, determine the design conditions ('Summer' heat flow in or 'Winter' heat flow out) according to the building class and climate zone for your project. Note: Building classes are defined by the NCC.
- STEP 3** Refer to the roof, wall or floor system applicable to your construction type to determine Total R-Value.

NOTE: Some applications may achieve Total R-Values sufficient to comply with the minimum performance levels of the Deemed-to-Satisfy requirements contained in the Energy Efficiency Provision of the NCC.

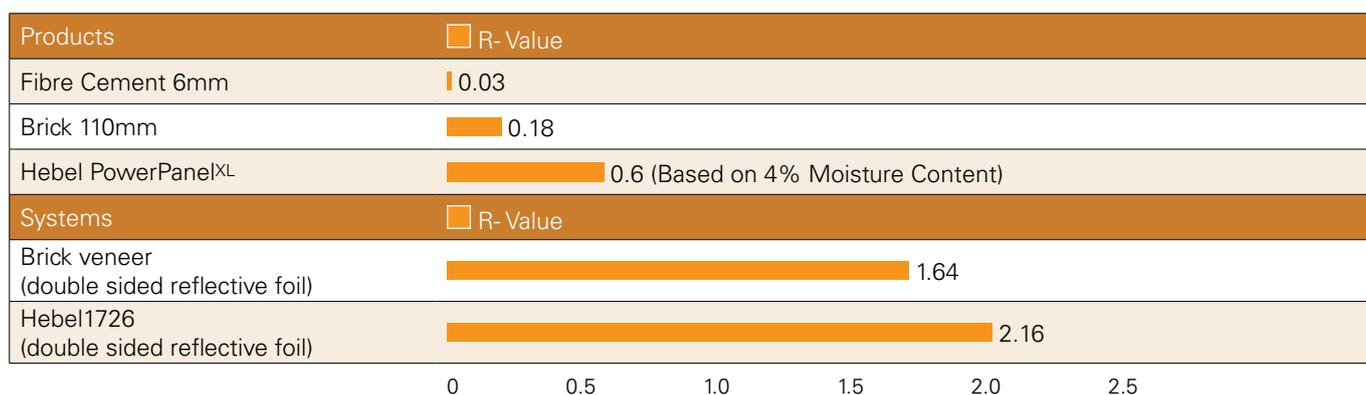
Table 2.3.1 Climate zones for thermal design

Climate Zone	1	2	3	4	5	6	7	8
	Below 300metres			Above 300metres				
Class 1-10,2,3,4,9c	Summer			Winter				
Class 5,6,7,8,9a,9b	Summer						Winter	
Class 1-10	Summer			Winter				
Class 2,3,4,5,6,7,8,9a,9b,9c	Summer			Winter				

**Table 2.3.2 Low-rise multi-residential buildings**

Climate Zone	Options		
1, 2,3,4 and 5	(a)	(i)	Achieve a minimum <i>Total R-Value</i> of 2.8.
	(b)	(i) (ii)	Achieve a minimum <i>Total R-Value</i> of 2.4; and Shade the external wall of the storey with a verandah, balcony, eaves, carport or the like, which projects at a minimum angle of 15 degrees in accordance with NCC 2022 Vol.2 H6D2[Figure 3.12.1.2. of NCC 2019]
6 and 7			Achieve a minimum <i>Total R-Value</i> of 2.8.
8			Achieve a minimum <i>Total R-Value</i> of 3.8.

**Table 2.3.3 Comparison of thermal properties**



**NOTES:**

- Sarking or insulation to be added to the above values where applicable to comply with NCC climate zone requirements.
- R-Values above (excluding Hebel PowerPanelXL solution) are taken from NCC 2022.
- Refer to Table 2.3.4 and 2.3.5 for Hebel PowerPanelXL configuration and thermal insulation options.
- R-Values provided for brick veneer have been provided by James Fricker calculation 107.50 dated 19/03/2024.

**Table 2.3.4 Thermal performance of Hebel PowerPanelXL External Wall System - timber stud frame**

CSR Code	Description						Total R-value m <sup>2</sup> .K/W	
	Platerboard	Stud frame	Batts	Wall wrap	Top hat cavity	Hebel Panel	Summer	Winter
CSR21716	10mm Gyprock Plasterboard Plus	70mm timber Stud frame	None	Polyair Performa 4.0 XHD	24mm	75mm thick Hebel PowerPanelXL	2.19	2.22
CSR21752			None	Thermoseal Wall Wrap prime			1.63	1.66
CSR21753			75 mm Bradford Gold wall Batts R1.5	Thermoseal Wall Wrap prime			2.25	2.37
CSR21717			70 mm Bradford Soundscreen Batts R2.0	Thermoseal Wall Wrap XP			3.03	3.15
CSR21718			70 mm Bradford Soundscreen Batts R2.0	Enviroseal™ RW Plus	2.68		2.79	
CSR21721			None	Polyair Performa 4.0 XHD	35mm		2.19	2.22
CSR21754			None	Thermoseal Wall Wrap prime			1.63	1.66
CSR21755			75 mm Bradford Gold wall Batts R1.5	Thermoseal Wall Wrap prime			2.25	2.37
CSR21722			70 mm Bradford Soundscreen Batts R2.0	Thermoseal Wall Wrap XP			3.03	3.15
CSR21723			70 mm Bradford Soundscreen Batts R2.0	Enviroseal™ RW Plus			2.68	2.79
CSR21726		90mm timber Stud frame	None	Polyair Performa 4.0 XHD		24mm	2.21	2.24
CSR21760			None	Thermoseal Wall Wrap prime	1.65		1.68	
CSR21762			90mm Bradford Gold wall Batts R2.0	Thermoseal Wall Wrap prime	2.72		2.87	
CSR21727			90mm Bradford Gold wall Batts R2.0	Thermoseal Wall Wrap XP	3.07		3.23	
CSR21728			90mm Bradford Gold wall Batts R2.5	Enviroseal™ RW Plus	3.09	3.24		
CSR21730			90mm Bradford Gold wall Batts R2.7	Enviroseal™ RW Plus	3.23	3.37		
CSR21733			None	Polyair Performa 4.0 XHD	35mm	2.21	2.24	
CSR21763			None	Thermoseal Wall Wrap prime		1.65	1.68	
CSR21764			90mm Bradford Gold wall Batts R2.0	Thermoseal Wall Wrap prime		2.72	2.87	
CSR21734			90mm Bradford Gold wall Batts R2.0	Thermoseal Wall Wrap XP		3.07	3.23	
CSR21735	90mm Bradford Gold wall Batts R2.5	Enviroseal™ RW Plus	3.09	3.24				
CSR21737	90mm Bradford Gold wall Batts R2.7	Enviroseal™ RW Plus	3.23	3.37				

**Table 2.3.5 Thermal performance of Hebel PowerPanel<sup>XL</sup> External Wall System - steel stud frame**

CSR Code	Description						Total R-value m <sup>2</sup> .K/W	
	Platerboard	Stud frame	Batts	Wall wrap	Top hat cavity	Hebel Panel	Summer	Winter
CSR21706	10mm Gyprock Plasterboard Plus	64mm steel Stud frame	None	Polyair Performa 4.0 XHD	24mm	75mm thick Hebel PowerPanel <sup>XL</sup>	2.14	2.17
CSR21707			70mm Bradford Soundscreen Batts R2.0	Thermoseal Wall Wrap XP			2.91	3.03
CSR21708			70mm Bradford Soundscreen Batts R2.0	Enviroseal™ RW Plus			2.54	2.65
CSR21711			None	Polyair Performa 4.0 XHD	35mm		2.14	2.17
CSR21712			70mm Bradford Soundscreen Batts R2.0	Thermoseal Wall Wrap XP			2.91	3.03
CSR21713			70mm Bradford Soundscreen Batts R2.0	Enviroseal™ RW Plus			2.54	2.65
CSR21756		70mm steel Stud frame	None	Thermoseal Wall Wrap Prime	24mm		1.53	1.57
CSR21757			75mm Bradford Gold Wall Batts R1.5	Thermoseal Wall Wrap Prime			2.09	2.20
CSR21758			None	Thermoseal Wall Wrap Prime	35mm		1.53	1.57
CSR21759			75mm Bradford Gold Wall Batts R1.5	Thermoseal Wall Wrap Prime			2.09	2.20
CSR21765		90mm steel Stud frame	None	Thermoseal Wall Wrap Prime	24mm		1.54	1.57
CSR21766			90mm Bradford Gold Wall Batts R2.0	Thermoseal Wall Wrap Prime			2.45	2.59
CSR21767			None	Thermoseal Wall Wrap Prime	35mm		1.54	1.57
CSR21768			90mm Bradford Gold Wall Batts R2.0	Thermoseal Wall Wrap Prime			2.45	2.59
CSR21740		92mm steel Stud frame	None	Polyair Performa 4.0 XHD	24mm		2.14	2.18
CSR21741			90mm Bradford Gold Wall Batts R2.0	Thermoseal Wall Wrap XP			3.02	3.18
CSR21742			90mm Bradford Gold Wall Batts R2.5	Enviroseal™ RW Plus			3.02	3.17
CSR21744			90mm Bradford Gold Wall Batts R2.7	Enviroseal™ RW Plus	35mm		3.16	3.31
CSR21747			None	Polyair Performa 4.0 XHD			2.14	2.18
CSR21748			90mm Bradford Gold Wall Batts R2.0	Thermoseal Wall Wrap XP			3.02	3.18
CSR21749			90mm Bradford Gold Wall Batts R2.5	Enviroseal™ RW Plus	35mm		3.02	3.17
CSR21751	90mm Bradford Gold Wall Batts R2.7		Enviroseal™ RW Plus	3.16		3.31		

**Table 2.3.6 Guidance on wall wrap/sarking**

Performance criteria	Guidance on wall wrap/sarking	Recommended wall wrap/ sarking	Reflective or non-reflective
Vapour barrier	Vapour barrier products are not recommended for condensation control in colder climate zones in conjunction with high insulation R Values.	Polyair Performa 4.0 XHD	Reflective double-sided
		Thermoseal Wall Wrap Prime	Reflective single-sided
		Thermoseal Wall Wrap XP	Reflective single-sided
Vapour permeable	Vapour permeable products are not recommended for use in tropical climate zones.	Enviroseal RW Plus	Non-reflective

**NOTES:**

1. Refer to NCC for state & territory variations.
2. Refer to NCC for alternative means of satisfying the required performance levels.
3. Refer to CSR Bradford product literature for design & installation requirements on wall wrap/ sarking and insulation.
4. The density of Gyprock plasterboard plus is 5.7 kg/m<sup>2</sup>.
5. Stated R-values in Tables 2.3.4 and 2.3.5 has been provided by J.Fricker calculations in report i107e, dated 15/04/2024, and report i107f dated 29/04/2024. Determinations based upon AS/NZS 4859:2018, including thermal bridging.
6. Stated R-values in Tables 2.3.4 and 2.3.5 includes 6mm skim render.
7. As per NCC 2022, where wall wrap is installed in an external wall it must be vapour permeable wall wrap for climate zones 6,7 and 8.
8. For systems where Thermoseal Wall Wrap Prime is used, timber frame size is 70mm x 35mm.

# 2.4 SOUND TRANSMISSION & INSULATION

## OVERVIEW

### Current NCC sound transmission and insulation requirements

The Hebel PowerPanel<sup>XL</sup> External Wall System is primarily used in buildings that have a domestic type of activity purpose. The NCC generally classifies these buildings into Class 1 or 10. The acoustic performance requirements for external walls in these buildings or their building elements are not currently stated in the NCC. If a building using the Hebel wall system was required to provide acoustic performance, then the performance level requirements for a building envelope and elements would be set by the relevant authorities (i.e. local councils, client specific requirements, etc).

### Design recommendations

Acoustic design is a complex science and there will be instances where a specialist acoustic consultant is required.

For walls requiring acoustic performance Hebel recommends:

1. Engaging a reputable acoustic consultant on a project-by-project basis to provide design advice and installation inspections
2. When selecting the appropriate components for the Hebel wall system, the designer or specifier must be aware that the laboratory  $R_w$  values are almost always higher than the field measured values. Therefore, allowances should be made for the lower expected field values during the selection of the system
3. Separate advice from a specialist acoustic consultant should be sought to determine the effect on acoustic performance due to any changes to the Hebel wall system, and any required modification of the installation details pertaining to the systems
4. Increasing cavity widths, using higher density or thicker insulation or plasterboard, will generally maintain or increase the acoustic performance of the Hebel wall system.

**Table 2.4.1 Acoustic performance of Hebel PowerPanel<sup>XL</sup> External Wall System - timber stud frame**

CSR Code	Description						Acoustic	
	Platerboard	Stud frame	Batts	Wall wrap	Top hat cavity	Hebel Panel	$R_w$	$R_w + C_{tr}$
CSR21716	10mm Gyprock Plasterboard Plus	70mm timber Stud frame	None	Polyair Performa 4.0 XHD	24mm	75mm thick Hebel PowerPanel <sup>XL</sup>	38	23
CSR21717			70mm Bradford Soundscreen Batts R2.0	Thermoseal Wall Wrap XP			40	25
CSR21718			70mm Bradford Soundscreen Batts R2.0	Enviroseal™ RW Plus			40	25
CSR21721			None	Polyair Performa 4.0 XHD	35mm		38	23
CSR21722			70mm Bradford Soundscreen Batts R2.0	Thermoseal Wall Wrap XP			41	26
CSR21723			70mm Bradford Soundscreen Batts R2.0	Enviroseal™ RW Plus			41	26
CSR21726		90mm timber Stud frame	None	Polyair Performa 4.0 XHD	24mm		38	23
CSR21727			90mm Bradford Gold Wall Batts R2.0	Thermoseal Wall Wrap XP			41	26
CSR21728			90mm Bradford Gold Wall Batts R2.5	Enviroseal™ RW Plus			41	26
CSR21730			90mm Bradford Gold Wall Batts R2.7	Enviroseal™ RW Plus			41	26
CSR21733			None	Polyair Performa 4.0 XHD	35mm		38	23
CSR21734			90mm Bradford Gold Wall Batts R2.0	Thermoseal Wall Wrap XP			42	27
CSR21735			90mm Bradford Gold Wall Batts R2.5	Enviroseal™ RW Plus			42	27
CSR21737			90mm Bradford Gold Wall Batts R2.7	Enviroseal™ RW Plus			42	27

**Table 2.4.2 Acoustic performance of Hebel PowerPanel<sup>XL</sup> External Wall System - steel stud frame**

CSR Code	Description						Acoustic	
	Platerboard	Stud frame	Batts	Wall wrap	Top hat cavity	Hebel Panel	$R_w$	$R_w + C_{tr}$
CSR21706	10mm Gyprock Plasterboard Plus	64mm steel Stud frame	None	Polyair Performa 4.0 XHD	24mm	75mm thick Hebel PowerPanel <sup>XL</sup>	40	30
CSR21707			70mm Bradford Soundscreen Batts R2.0	Thermoseal Wall Wrap XP			43	32
CSR21708			70mm Bradford Soundscreen Batts R2.0	Enviroseal™ RW Plus			43	32
CSR21711			None	Polyair Performa 4.0 XHD	35mm		40	31
CSR21712			70mm Bradford Soundscreen Batts R2.0	Thermoseal Wall Wrap XP			44	33
CSR21713			70mm Bradford Soundscreen Batts R2.0	Enviroseal™ RW Plus			44	33
CSR21740		92mm steel Stud frame	None	Polyair Performa 4.0 XHD	24mm		40	31
CSR21741			90mm Bradford Gold Wall Batts R2.0	Thermoseal Wall Wrap XP			44	33
CSR21742			90mm Bradford Gold Wall Batts R2.5	Enviroseal™ RW Plus			44	33
CSR21744			90mm Bradford Gold Wall Batts R2.7	Enviroseal™ RW Plus			44	33
CSR21747			None	Polyair Performa 4.0 XHD	35mm		40	31
CSR21748			90mm Bradford Gold Wall Batts R2.0	Thermoseal Wall Wrap XP			44	33
CSR21749			90mm Bradford Gold Wall Batts R2.5	Enviroseal™ RW Plus			44	33
CSR21751			90mm Bradford Gold Wall Batts R2.7	Enviroseal™ RW Plus			44	33

NOTE: Acoustic values in Tables 2.4.1 and 2.4.2 are based on acoustic assessment 20140366.34/1909A/R3/GW.

# 2.5 COATING REQUIREMENTS

Hebel PowerPanel<sup>XL</sup> panels require an appropriate external coating system and sealant detailing to ensure a water resistant and vapour permeable building envelope is achieved.

Generally, the external face of the Hebel PowerPanel<sup>XL</sup> panel is coated with a high build acrylic levelling and finishing system, applied in accordance with the recommendations of the coating manufacturer.

NOTE: The coating system is a necessary part of the Hebel PowerPanel<sup>XL</sup> external wall system to ensure the durability of the panel, validity of the applicable warranty and weathertightness of wall system is maintained. Hebel recommends the coating system to be applied as soon as possible, but within 60 days from the date of installation of Hebel PowerPanel<sup>XL</sup> panels.

Prior to application of the coating it must be ensured that:

- The PowerPanel<sup>XL</sup> panels are dry
- The panel substrate is clean from any dirt, imperfections or contamination that may prevent adhesion of the coating system onto the panel

## PERFORMANCE REQUIREMENTS

The following are items to be considered when selecting a coating system:

### Manufacturer approved:

- Hebel recommends the use of a three layer coating system. The application of a two layer coating system is also acceptable. The acrylic coating manufacturer must ensure they have evidence of suitability of their coating system over the Hebel substrate, where a two layer coating system is used.

NOTE: Where other manufacturer's coating systems are applied to Hebel external walls these coatings systems must be warranted by the coating manufacturer as appropriate for coating an AAC substrate. As a minimum coating manufacturers must verify and warrant coating system performance to the properties defined below. Coating application rates and film thickness must comply with (or exceed) the coating system manufacturer's minimum specifications.

### Surface adhesion:

- The substrate preparation and coating application should be in accordance with the coating manufacturer's specification.
- Before applying finishes in coastal areas (Refer to Section 2.1 – Durability), all PowerPanel<sup>XL</sup> panels must be thoroughly washed with fresh water to remove any salt residue. Refer to coating manufacturer for additional requirements.

### Water resistance:

- The primary objective of the coating system is to prevent liquid water ingress, yet allow water vapour transmission both in and out of the AAC substrate.
- Proven water resistance capability: Transmission: <10 grams/m<sup>2</sup>/24hr/1kPa.

### Water vapor permeability:

- For a coating to allow the 'escape' of water vapour, the coating must be vapour permeable.
- The coating system should comply with the following performance parameters:
  - Equivalent air layer thickness of water vapor diffusion  $S_d \leq 2m$ .

NOTE:

- A coating with an ( $s_d \leq 2m$ ) has less resistance to water vapour diffusion (escape) than a static 2m thick air layer.

### Compatibility:

- Ensure the coating system is compatible with the AAC substrate and construction system components, i.e:
  - Coatings may not adhere to silicone or other sealants and mastics.
  - Excessive joint adhesive or mortars smears across the panel face may require removal or specific primers.

### Durability:

- The coating must be durable and should not overly deteriorate with exposure to light (UV) and weather for the life of the coating system manufacturer's warranty.

### Coating Elasticity:

- The coating system must be able to bridge a 1mm minimum crack width.
- The coating system manufacturer can specify the minimum design specification (thickness), so that the coating is serviceable and durable.

IMPORTANT: This list of performance requirements indicates that a specific fit-for purpose coating system must be adopted, and that a simple paint coating would most likely be an inadequate coating system. Variations to the coating system must be approved and warranted by the coating system manufacturer or representative. Coating application rates and film thickness must comply with (or exceed) the coating system manufacturer's minimum specifications.

### Maintenance:

All external coating systems and sealants/caulking should be cleaned and maintained on a regular basis. Please refer to Section 2.1 - Durability.

Contact reputable coating manufacturers for their current coating maintenance guide.

# 2.6 WEATHERPROOFING

## SEALANTS

All control joints must be sealed with a suitable external grade acoustic and/or fire rated paintable sealant. All gaps between the PowerPanel<sup>XL</sup> panels and framing around windows must be caulked with an appropriate external grade sealant.

NOTE: Caulking should be applied prior to base coat with care taken not to cut the caulking during application of trowelled on render/coating.

The sealant should be installed in accordance with the sealant manufacturer's specifications.

## WALL FLASHINGS

In general, flashings shall be designed and installed in accordance with SAA-HB39 2015 – Installation Code for Metal Roofing and Wall Cladding.

NCC 2022 Volumes One and Two contain Performance Requirement H4P7 relating to Condensation and Water Vapour Management and requirement states:

## CONDENSATION MANAGEMENT

Risks associated with water vapour and condensation must be managed to minimise their impact on the health of occupants.

This requirement implies that moisture levels resulting from condensation within the building must be managed such that they do not cause undue (health) impacts to occupants living within the building.

Hebel has undertaken Hygrothermal modelling in accordance with Verification Method, H4V5 - Verification of condensation management of NCC 2022 of the Hebel PowerPanel<sup>XL</sup> Dual Zero Boundary and External Wall Systems to justify that moisture levels satisfy the intent of Performance Requirement H4P7 and that omitting the installation of wall wrap in the Hebel PowerPanel<sup>XL</sup> Dual Zero Boundary and External Wall Systems will not cause a risk of condensation. Report Ref: 0192[00] Hygrothermal Assessment prepared by Speckel - Dated 20/02/23.

However, where a wall wrap is installed, particularly in climatic zones 6,7 & 8, this wall wrap must be a vapour permeable membrane.

## WALL WRAP

For Hebel PowerPanel<sup>XL</sup>, wall wrap is recommended for insulation, condensation control as well as a corrosion barrier over CCA treated timber frames.

Where wall wrap is installed in an external wall it must be of a vapour permeable type for climate zones 6, 7 and 8 as per NCC 2022 Vol.2 H4D9 (NCC 2019 Volume Two Clause 3.8.7.2) Pliable building membrane. Wall wrap must be designed and installed in accordance with AS/NZS 4200 Part 1 – Materials and Part 2 – Installation.

## ZERO BOUNDARY WALL SYSTEM

Hebel zero boundary walls are used when access is unavailable from outside. The design and installation of the zero boundary walls should be based on the information and details provided in this guide.

On zero boundary wall applications where the external wall is up against another existing building, it is good practice to flash the top of the wall to the adjacent property to shelter the wall from external weather conditions. In cases where Hebel zero boundary wall is higher than the wall on the adjacent property, the Hebel wall cladding at the upper level is considered an external wall system and therefore should be coated as per the recommendations in this guide. For more details refer to figures 3.6.6.7 and 3.6.6.8 and Hebel technical update (Doc Ref: Boundary wall weathertightness. doc - 14 Nov 2011).

## POWERPANEL<sup>XL</sup> EXTERNAL WALL SYSTEM

The Hebel PowerPanel<sup>XL</sup> External Wall System has been tested (and results of the test assessed by Xavier Knight) in accordance with the Verification Methods of NCC 2022, specifically the verification methods F3V1 for clause F3P1 (Volume One) and H2V1 for clause H2P2 (Volume Two).

The results of this test demonstrate the Hebel PowerPanel<sup>XL</sup> External Wall System (with adhesive applied at the panel joints) and with a suitable acrylic coating system applied over the panel will comply with the performance requirements NCC 2022 for Wind Categories N2 & N3, specifically the verification methods F3V1 for clauses F3P1 (Volume One) and H2V1 for clause H2P2 Volume Two).

## FACE-SEALED SYSTEM

The Hebel PowerPanel<sup>XL</sup> External Wall System is considered a face-sealed system (functioning as a closed, un-drained cavity wall system, excluding weepholes) whereby the external coatings and sealant at control joints, around external window and door openings etc. form the weather tightness barrier to the external wall of the building. As such, a fit-for-purpose acrylic coating system and compatible external grade sealants, applied in accordance with manufacturers specification (and maintained in accordance with the manufacturers maintenance schedule) are important in ensuring the ongoing weather tightness performance and long term durability of the external wall system.

# 3.1 INSTALLATION OVERVIEW

## 1. COMPLETE FRAMES AND TRUSSES

### 2. DPC

- Fix DPC to bottom plate of frame
- Cover rebate completely
- Overlap DPC at corners



### 3. WALL WRAP

- Install wrap as specified by supplier ensuring that it overlaps DPC at base



### 4. TOP HATS

- Check control joint layouts for installation of discontinuous top hats
- Check the number of top hats and screws required (refer to tables on pages 6 and 7)
- Use packers and pack top hat to string line where required, screw to frame
- Check with a straight edge/spirit level that top hats are plumb
- Install top hats above and below openings



## 5. CUTTING PANELS

- Cut panels to size (refer to Appendix A notes on page 54)
- Ensure any exposed steel reinforcing has been coated with Hebel anti-corrosion paint



## 6. ADHESIVE

- Mix adhesive to a thick flowable consistency
- Apply Hebel adhesive to entire edge of panel with notched trowel
- The use of notched trowel to apply Hebel adhesive at the panel joints is essential to ensure sufficient adhesive is applied. Insufficient application of adhesive at the panel joints may result in hairline cracks at the joints



## 7. CONTROL JOINT

- Check control joint layout
- Install backing rod into control joint at the required depth
- Apply suitable sealant to control joint
- Clean up any excess sealant ensuring it does not adhere to panel face



## 8. HEBEL POWERPANEL<sup>XL</sup> PANELS

- Corner PowerPanel<sup>XL</sup> panel to be installed first, lifting into place using panel lifters
- Fix panel to top hats (refer to tables on pages 6 and 7)
- Check panel is straight and level
- Continue installation by lifting panels into position
- Butt panel tightly to adjoining panel, screwing off as you go
- Adhesive should slightly ooze from the joint
- Once the joint adhesive is semi hard it can be cleaned up with a pallet knife, ensuring adhesive is flush with the panel face
- Patch holes and panel damage



## 9 FINISH WALL

- Trim off excess DPC
- Lightly sand and prepare surface ready for acrylic coating



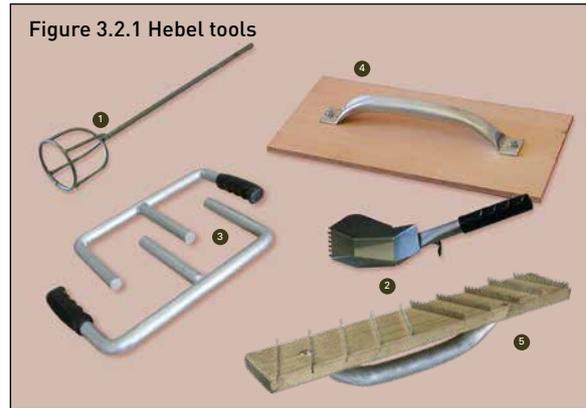
## 3.2 TOOLS AND EQUIPMENT

The basic tools required to assist in the installation of the PowerPanel<sup>XL</sup> External Wall System are shown in Figure 3.2.1. These may be purchased through a Hebel distributor and include:

- 1. Stirrer** – fitted to the electric drill, the stirrer is used to mix the Hebel Mortar, Hebel Adhesive and base levelling coat render inside the mixing bucket
- 2. Notched trowel** – the notched trowel is used to apply the Hebel Adhesive to the Hebel surfaces. The width of the trowel must match the panel thickness to ensure the adhesive is applied with full and even coverage
- 3. Panel lifters** – used to carry the panels around the work site
- 4. Sand float** – used to remove excess Hebel Adhesive and smooth joints between panels
- 5. Levelling plane** – used to even out inconsistencies in the Hebel panels.

Extra equipment will also be required and includes the following:

- Power drill (clutch driven)
- Power saw with metal or diamond tipped cutting blades
- Dust extraction system
- Sockets for screws
- Personal Protective Equipment (PPE) such as goggles, ear muffs/plugs and face mask used when site cutting the PowerPanel<sup>XL</sup> panels.



## 3.3 INSTALLATION OF SERVICES

The installation of services in the building are the same as the methods currently being used throughout the industry.

Services should be installed through the frame to avoid interfering with top hat layout, but if they are to be fixed on the outside of the frame, they should only run horizontally



Figure 3.3.1 Installed piping services prior to the installation of Hebel PowerPanel<sup>XL</sup>

parallel to the top hats – typically 300mm up from the bottom plate.

Penetrations through the PowerPanel<sup>XL</sup> panel for services should be neatly filled and the joint sealed.



Figure 3.3.2 Neat finishes of installed services

## 3.4 EXTERNAL ALUMINIUM RENDER BEAD (OPTIONAL)



Figure 3.4.1 Neat finish of horizontal joints



The external aluminium render bead can be used as an option at horizontal joints to provide neat and consistent finish joints. After installation of the PowerPanel<sup>XL</sup> panels, the render bead is applied and hold onto place by using Hebel adhesive. Suitable external grade sealant is to be applied at the joint before rendering.

### NOTES:

The external aluminium render bead is not recommended in the following conditions:

- Within 100m of breaking surf.
- Within 100m of heavy industrial emissions.
- Areas exposed to prevailing winds containing salt of heavy industrial emissions.
- Where continuous or cyclical moisture is present (eg retaining walls, planter boxes, garden beds)
- Environments where bore water or soils contain high chloride content.

# 3.5 CONSTRUCTION DETAILS – OVERVIEW

Table 3.5.1 CONSTRUCTION DETAILS

Single storey construction details	Isometric view detail panel supported at base	Figure 3.6.1.1	Page 28
	Isometric view detail panel suspended	Figure 3.6.1.2	Page 28
	Hip roof elevation	Figure 3.6.1.3	Page 29
	Gable end elevation	Figure 3.6.1.4	Page 29
	Typical section detail	Figure 3.6.1.5	Page 30
	High wall section detail (3900mm max.)	Figure 3.6.1.6	Page 30
Two storey construction details	Isometric view detail	Figure 3.6.2.1	Page 31
	Hip roof elevation	Figure 3.6.2.2	Page 32
	Gable end elevation	Figure 3.6.2.3	Page 32
	Typical timber frame section using joists with >1% shrinkage	Figure 3.6.2.4	Page 33
	Steel frame section or engineered joists with ≤1% shrinkage	Figure 3.6.2.5	Page 33
	Hebel external wall cladding detail extending above first floor	Figure 3.6.2.6	Page 34
Two storey addition details	Isometric view detail	Figure 3.6.3.1	Page 34
	Typical section with brick veneer below	Figure 3.6.3.2	Page 35
	Typical section with double brick below	Figure 3.6.3.3	Page 35
Fixing & installation details	Hebel PowerPanel <sup>XL</sup> External Wall System fixing detail	Figure 3.6.4.1	Page 36
	Hebel PowerPanel <sup>XL</sup> zero Boundary Wall System fixing detail	Figure 3.6.4.2	Page 36
	Screw layout drawing	Figure 3.6.4.3	Page 36
	PowerPanel <sup>XL</sup> zero Boundary Wall System	Figure 3.6.4.4	Page 36
Footing junction details	Junction to shallow concrete footing	Figure 3.6.5.1	Page 37
	Junction to deep concrete edge beam	Figure 3.6.5.2	Page 37
	Junction to masonry earth retaining wall	Figure 3.6.5.3	Page 37
	Junction to masonry dwarf wall	Figure 3.6.5.4	Page 37
	Junction to existing piers/stumps	Figure 3.6.5.5	Page 38
	Base detail suspended floor - pier connection	Figure 3.6.5.6	Page 38
	Junction to shallow concrete edge beam	Figure 3.6.5.7	Page 39
	Junction to steel angle	Figure 3.6.5.8	Page 39
	Junction to Hebel below finish ground	Figure 3.6.5.9	Page 39
	Junction to Hebel below concrete pavement slab	Figure 3.6.5.10	Page 39
Wall junction details & sections	Typical roof eaves detail – Option 1	Figure 3.6.6.1	Page 40
	Typical roof eaves detail – Option 2	Figure 3.6.6.2	Page 40
	Roof to wall junction detail - Option 1	Figure 3.6.6.3	Page 40
	Roof to wall junction detail - Option 2	Figure 3.6.6.4	Page 40
	Typical roof eaves detail for zero boundary wall systems	Figure 3.6.6.5	Page 40
	Balcony detail	Figure 3.6.6.6	Page 40
	Zero boundary wall detail to Hebel PowerPanel <sup>XL</sup> external wall system	Figure 3.6.6.7	Page 41
	Zero boundary wall detail to brick veneer	Figure 3.6.6.8	Page 41

Wall junction details & sections	Parapet capping	Figure 3.6.6.9	Page 41
	Hebel to pitched roof junction	Figure 3.6.6.10	Page 41
	Gable end wall detail	Figure 3.6.6.11	Page 42
	Gable end wall detail – lintel panel over window	Figure 3.6.6.12	Page 42
	Beam penetration detail	Figure 3.6.6.13	Page 42
	Column detail (glued and screwed)	Figure 3.6.6.14	Page 42
Control joint details	Internal corner	Figure 3.6.7.1	Page 43
	External corner	Figure 3.6.7.2	Page 43
	Typical detail for control joints positioned on corner	Figure 3.6.7.3	Page 44
	Typical detail for control joints positioned away from a corner	Figure 3.6.7.4	Page 44
	Typical horizontal control joint – engineered timber or steel frame	Figure 3.6.7.5	Page 45
	Horizontal control joint – cavity brickwork to Hebel PowerPanel <sup>XL</sup>	Figure 3.6.7.6	Page 45
	Horizontal control joint – Brick veneer to Hebel PowerPanel <sup>XL</sup> - Option 1	Figure 3.6.7.7	Page 45
	Horizontal control joint – Brick veneer to Hebel PowerPanel <sup>XL</sup> - Option 2	Figure 3.6.7.8	Page 45
	Typical vertical control joint	Figure 3.6.7.9	Page 45
	Typical vertical control joint with double studs	Figure 3.6.7.10	Page 45
	Control joint – aligned top hats on double stud	Figure 3.6.7.11	Page 46
	Control joint – discontinuous top hats on a single stud	Figure 3.6.7.12	Page 46
	Typical window control joint detail – lintel over	Figure 3.6.7.13	Page 46
Door & window details	Typical window sill detail – aluminium window frame – Option 1	Figure 3.6.8.1	Page 47
	Typical window sill detail – aluminium window frame – Option 2	Figure 3.6.8.2	Page 47
	Typical window sill detail – aluminium window frame – Option 3	Figure 3.6.8.3	Page 47
	Header detail	Figure 3.6.8.4	Page 47
	Garage head detail	Figure 3.6.8.5	Page 47
	Garage door – jamb detail – Option 1	Figure 3.6.8.6	Page 47
	Garage door – jamb detail – Option 2	Figure 3.6.8.7	Page 47
	Sliding door sill detail – Concrete sill < 270mm	Figure 3.6.8.8	Page 48
	Sliding door sill detail – PowerPanel <sup>XL</sup> sill > 270mm	Figure 3.6.8.9	Page 48
Miscellaneous detail	Panel layout drawing – Plan view	Figure 3.6.9.1	Page 49

**Project specific requirements: please contact CSR Hebel for advice on any project specific designs not covered in this Design and Installation Guide.**

# 3.6 CONSTRUCTION DETAILS

## 3.6.1 SINGLE STOREY CONSTRUCTION DETAILS

Figure 3.6.1.1 Single storey construction – isometric view detail panel supported at base

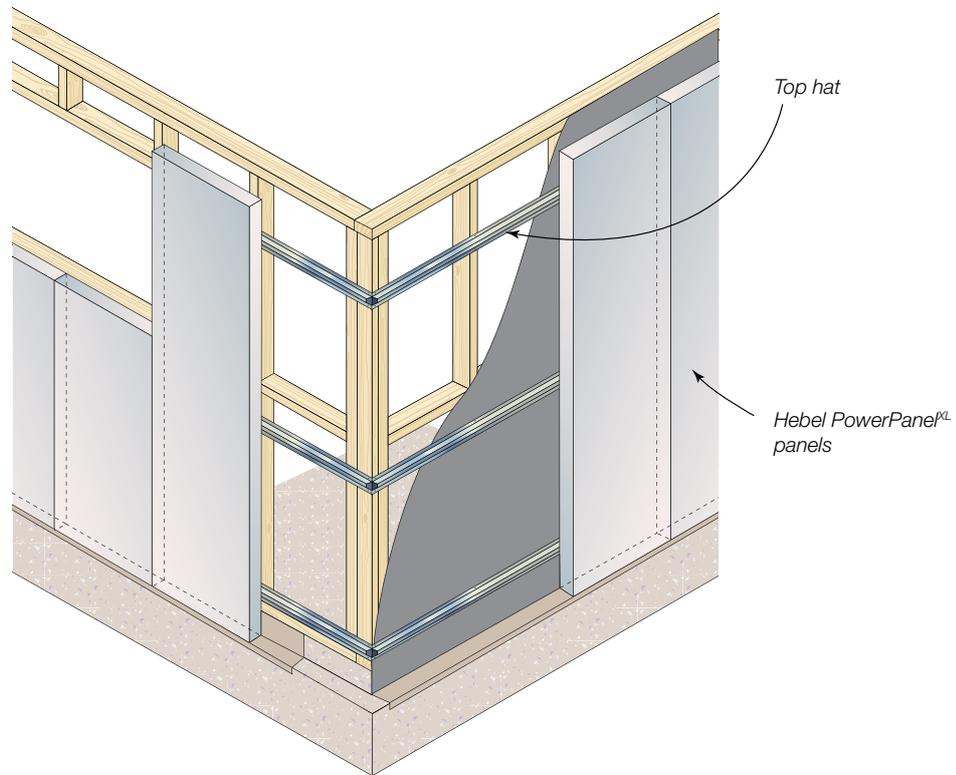
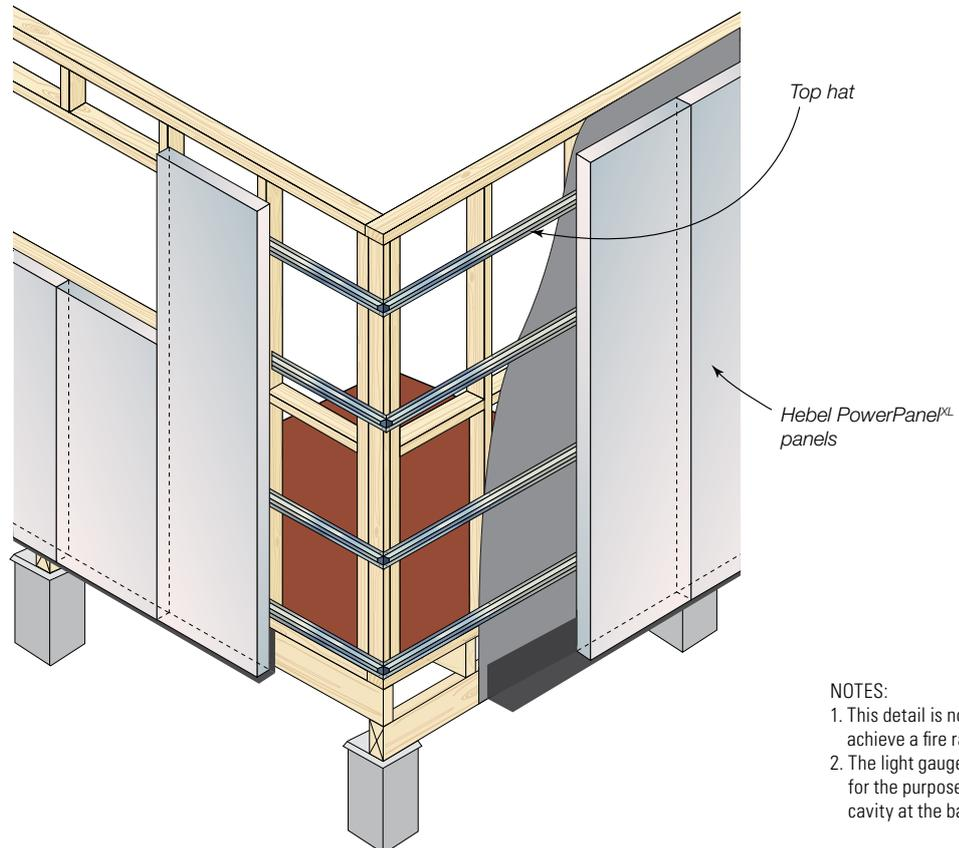


Figure 3.6.1.2 Single storey construction – isometric view detail panel suspended



- NOTES:
1. This detail is not considered to achieve a fire rating level.
  2. The light gauge steel angle is for the purpose of closing the cavity at the base of the wall.

Figure 3.6.1.3 Single storey construction – hip roof elevation

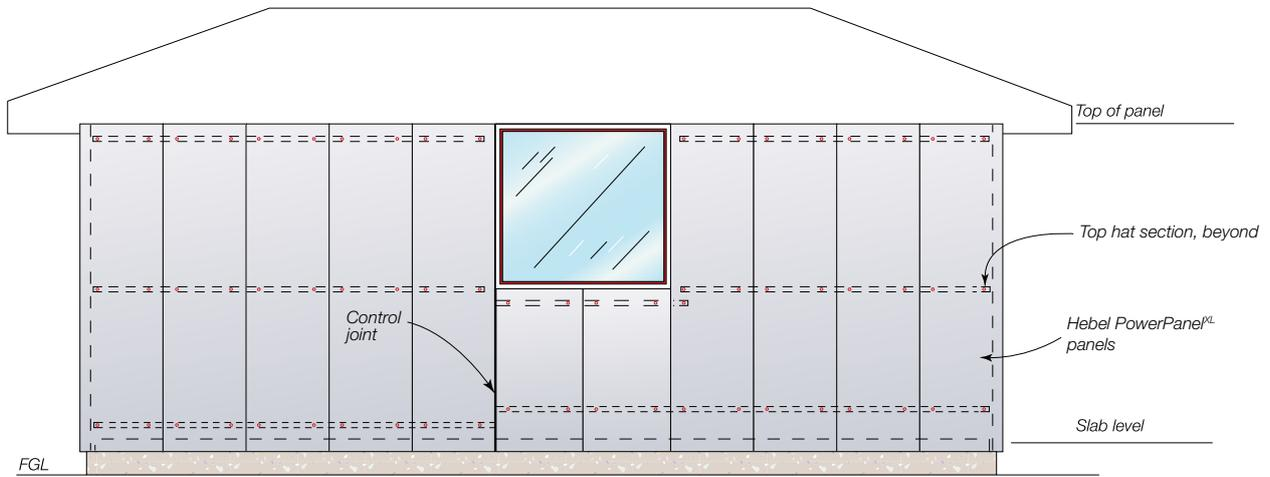
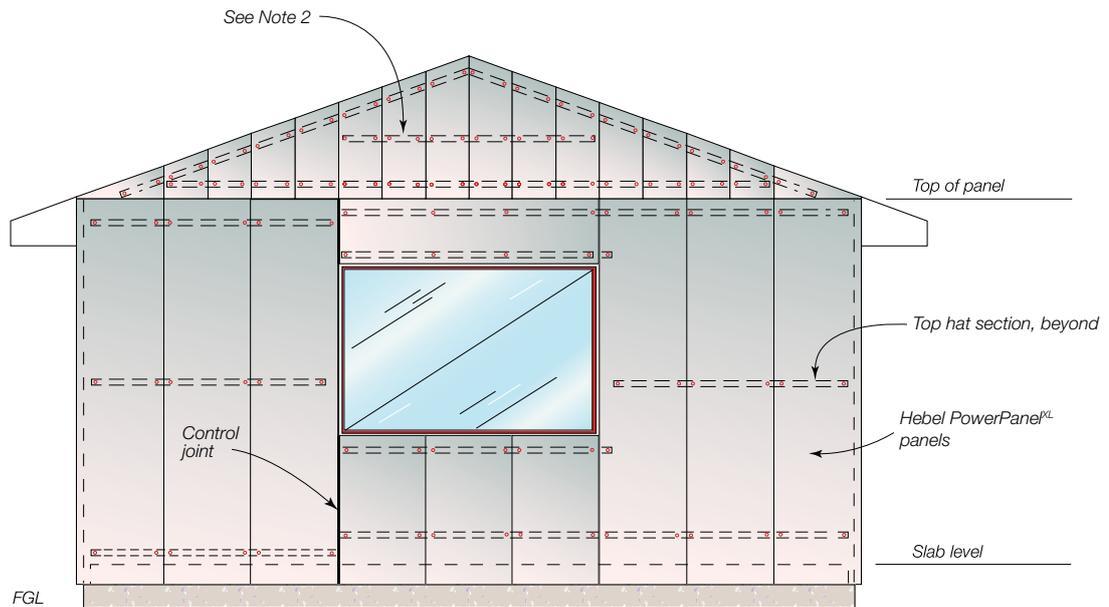


Figure 3.6.1.4 Single storey construction – gable end elevation



NOTES:

1. Number of top hats and top hat spacing to be confirmed by the building designer.
2. Additional top hats may be required, for suspended panels. Refer to Table 1.2.4 of this guide.
3. These details have not shown the set-out of top hats to accommodate control joint locations. This is the responsibility of the building designer.
4. Horizontally installed Hebel PowerPanel<sup>XL</sup> panels above openings can be installed with top hat sections running horizontally or vertically. A minimum 3 top hat sections will be required for vertically installed top hats. All top hats to be spaced evenly, with the two outer top hats installed 250mm (maximum) from the end of the PowerPanel<sup>XL</sup>. Refer to design tables 1.2.1 and 1.2.2.

Figure 3.6.1.5 Single storey construction – typical section detail

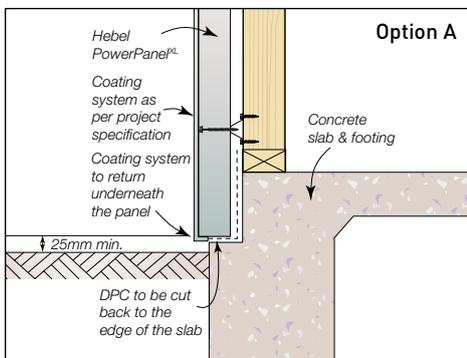
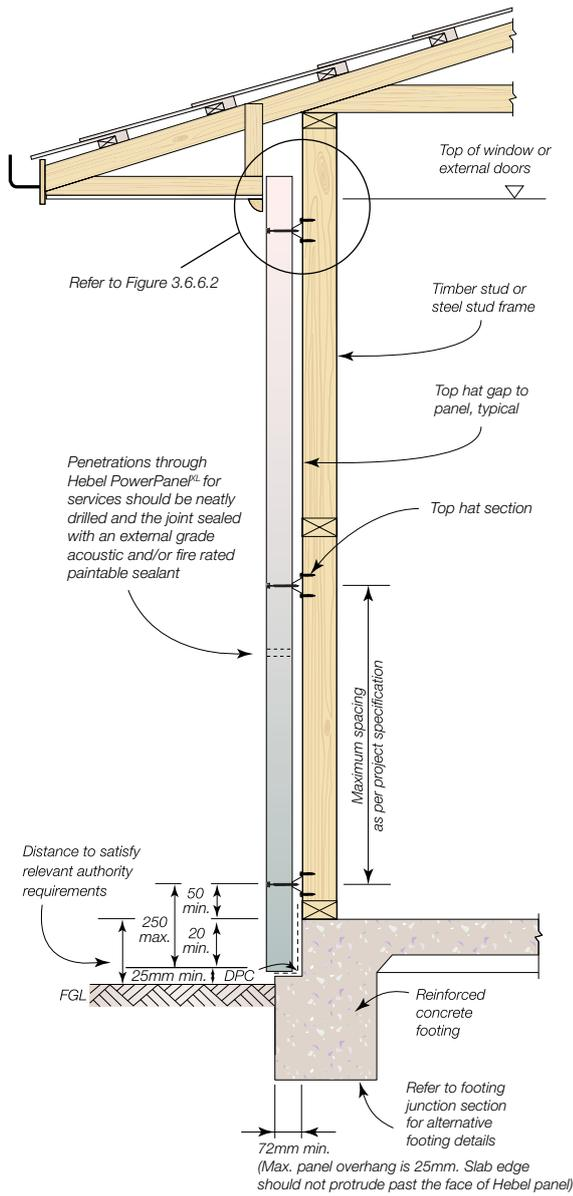
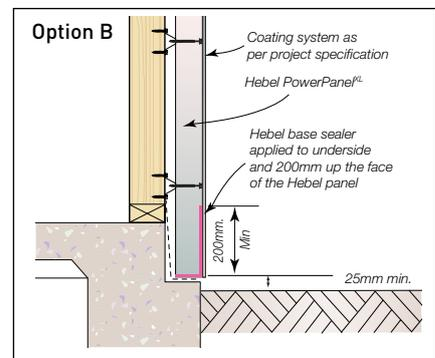
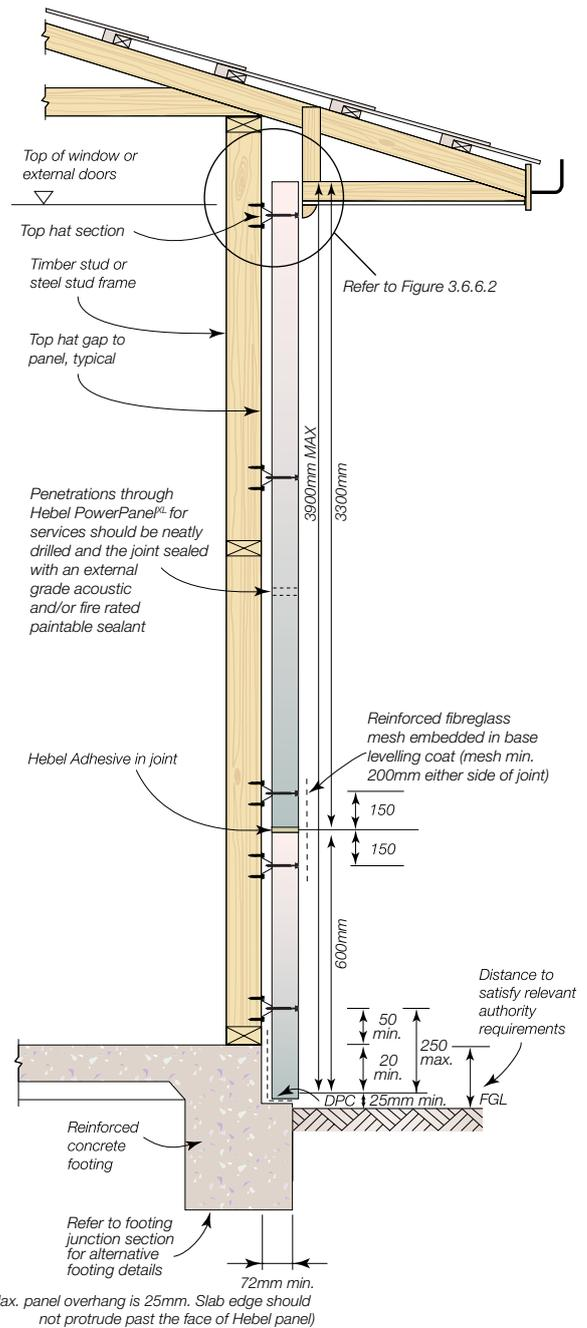


Figure 3.6.1.6 Single storey construction – high wall section detail (3900mm max.)



NOTES:

- Figures 3.6.1.5 and 3.6.1.6 slab edge details do not comply with the termite visible inspection zone requirements. Alternate termite management systems must be used when selecting these details. It is the responsibility of the builder to provide a suitable physical or chemical barrier in accordance with AS 3660.
- Hebel PowePanelXL panels are supported at the base on concrete slab edge.
- The distance from the underside of the PowerPanelXL panel to Finished Ground Level (FGL) may be 25mm min. or as per relevant authority requirements, see option A and B. Ensure soil is cut away at the slab edge to provide enough room to accommodate the coating of the underside of the panel (applies to option A only). For more details please contact Hebel Technical services to obtain a copy of Hebel Technical Update TU-033.
- Where the slab edge is rendered on sites that contain saline soils, please refer to page 10 of the guide for further details.

### 3.6.2 TWO STOREY CONSTRUCTION DETAILS

Figure 3.6.2.1 Two storey construction – isometric view detail

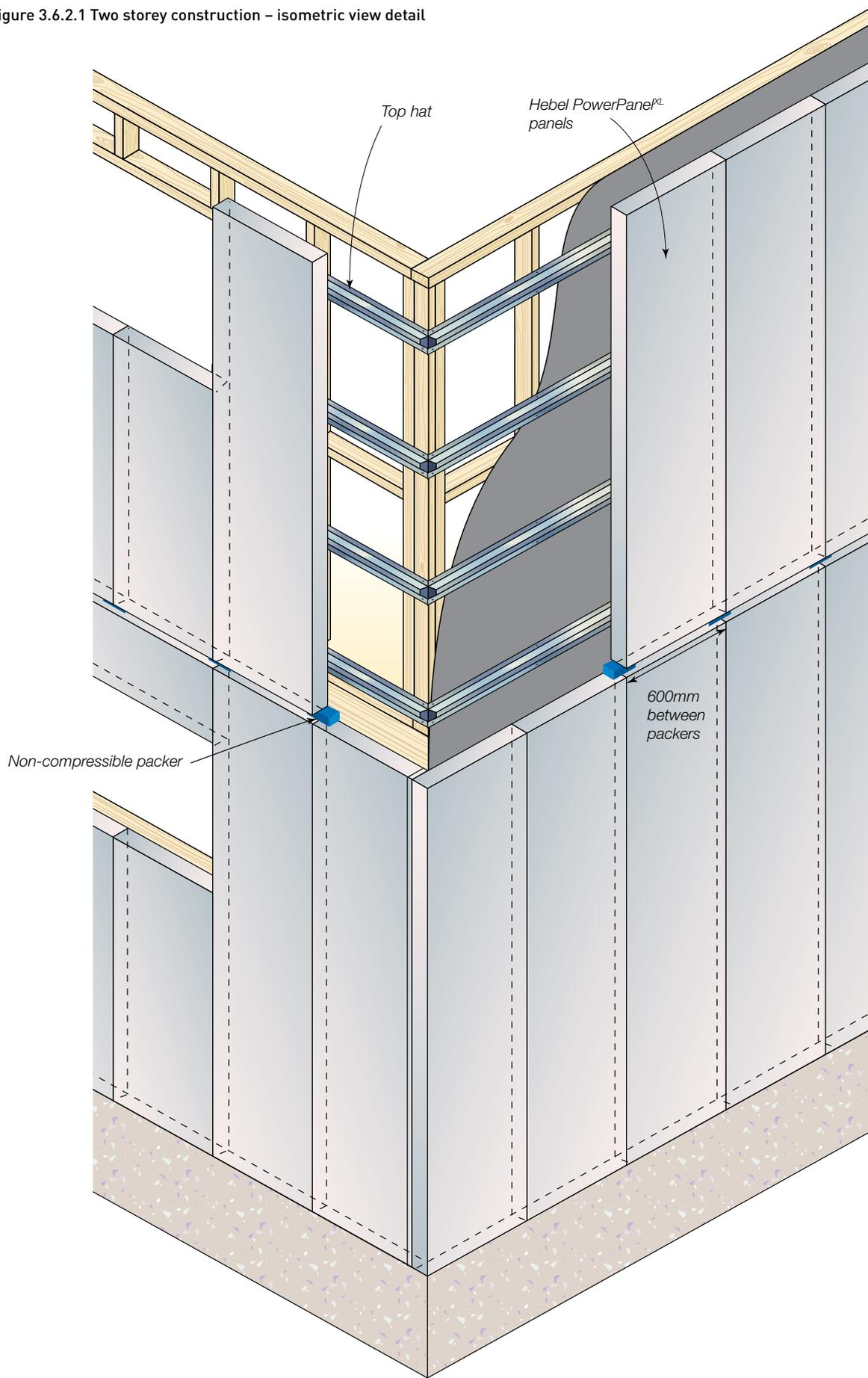


Figure 3.6.2.2 Two storey construction – hip roof elevation

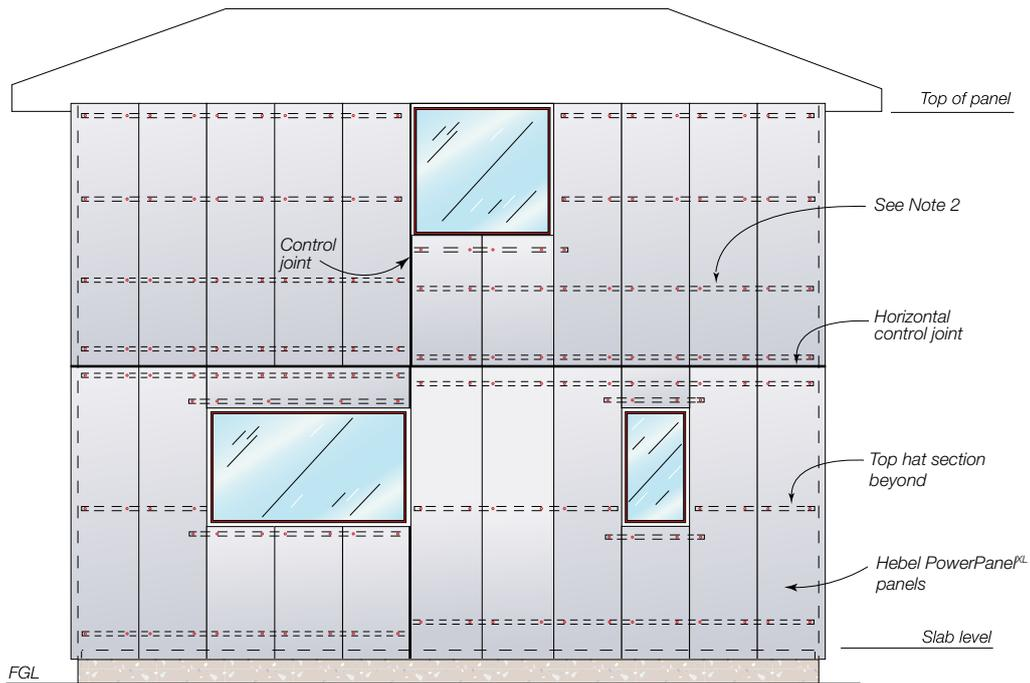
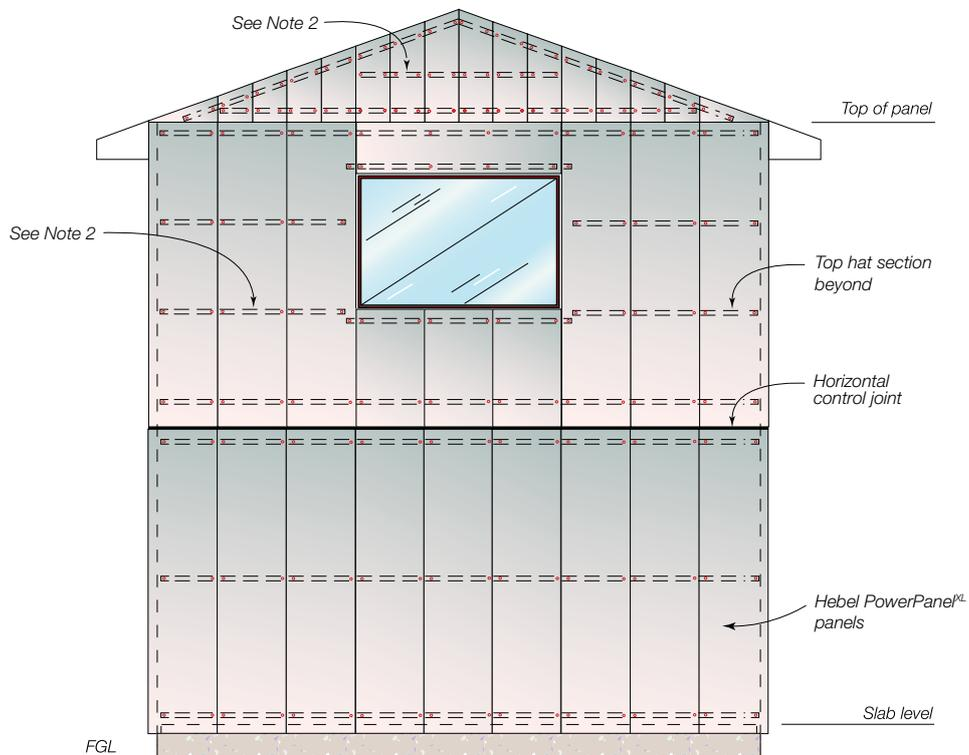


Figure 3.6.2.3 Two storey construction – gable end elevation



NOTES:

1. Number of top hats and top hat spacing to be confirmed by the building designer.
2. Additional top hats may be required, for suspended panels. Refer to Table 1.2.4 of this guide.
3. These details have not shown set-out of top hats to accommodate control joint locations. This is the responsibility of the building designer.
4. Frame design of lower floor to allow for extra load on wall from upper floor PowerPanelXL panels.
5. Minimum four horizontal top hats required for upper floor PowerPanelXL panels.
6. Horizontally installed Hebel PowerPanelXL panels above openings can be installed with top hat sections running horizontally or vertically. A minimum 3 top hat sections will be required for vertically installed top hats. All top hats to be spaced evenly, with the two outer top hats installed 250mm (maximum) from the end of the PowerPanelXL. Refer to design tables 1.2.1 and 1.2.2.

Figure 3.6.2.4 Two storey construction – typical timber frame section using joists with >1% shrinkage

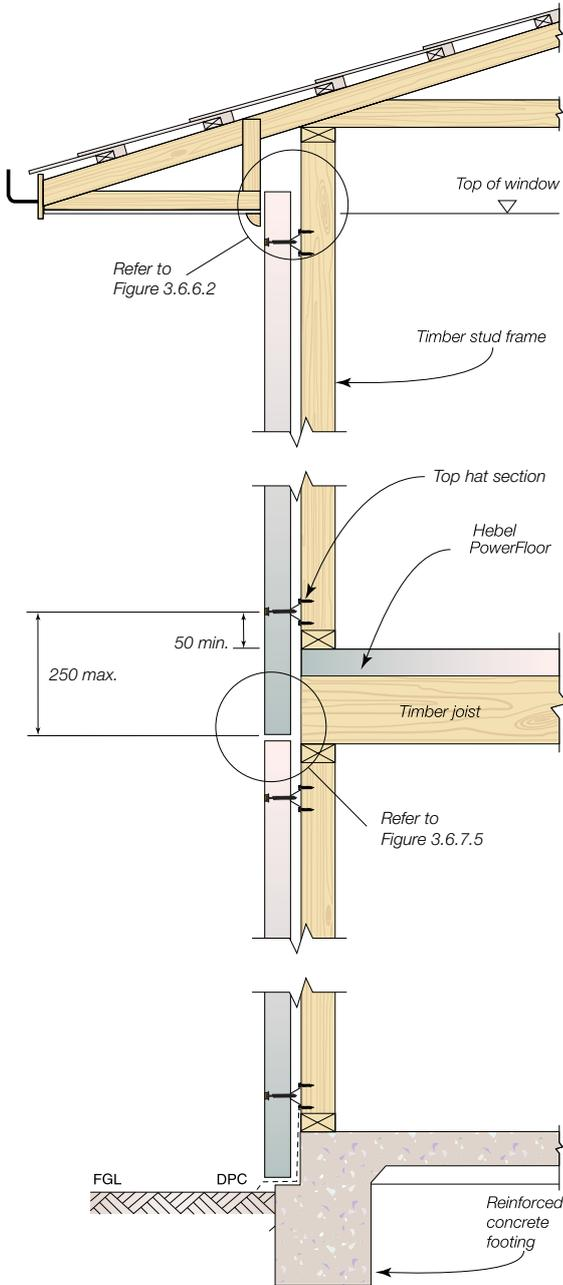
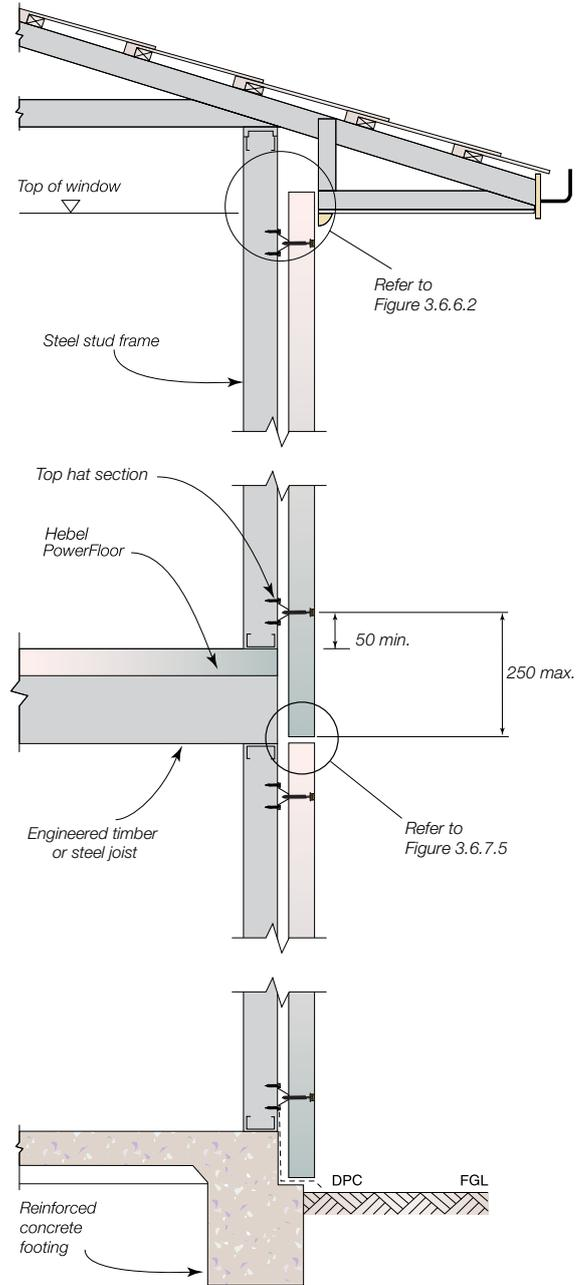


Figure 3.6.2.5 two storey construction – steel frame section or engineered joists with  $\leq 1\%$  shrinkage

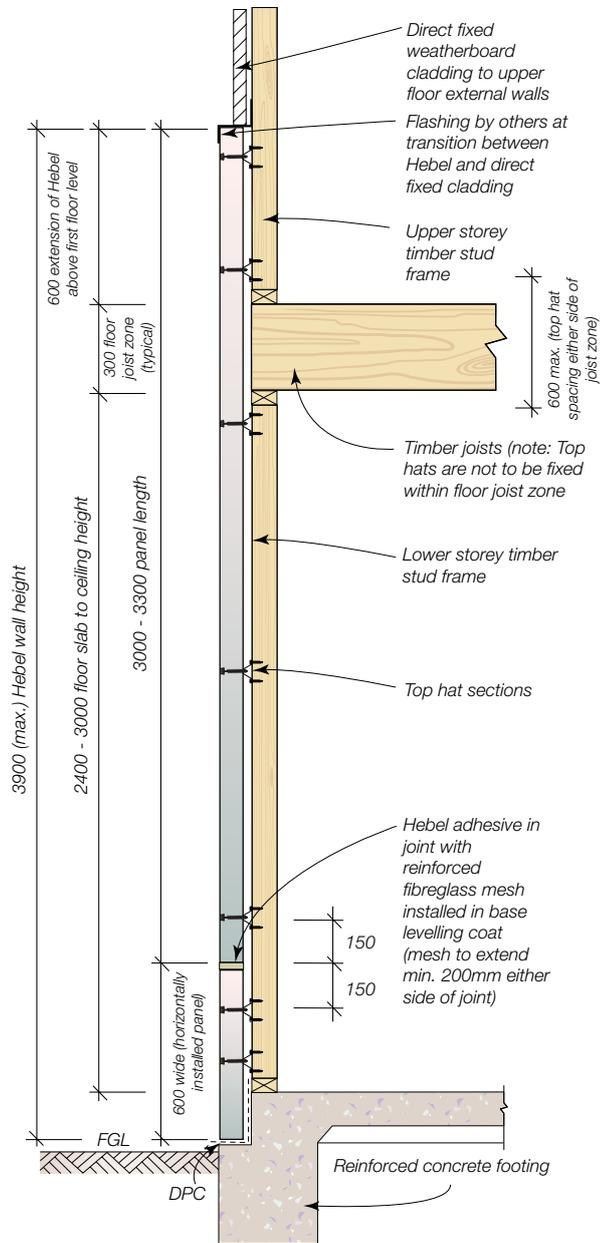


NOTES:

1. Lower storey Hebel PowerPanel<sup>XL</sup> Panels are supported at the base on concrete slab edge.

### 3.6.3 TWO STOREY ADDITION DETAILS

Figure 3.6.2.6 Hebel external wall cladding detail extending above first floor



Note: 600mm wide (horizontally installed panel) can be installed above full length panel provided Hebel adhesive in joint with reinforced fibreglass mesh is installed in base levelling coat (mesh to extend min. 200mm either side of joint)

Figure 3.6.3.1 Two storey addition – isometric view detail

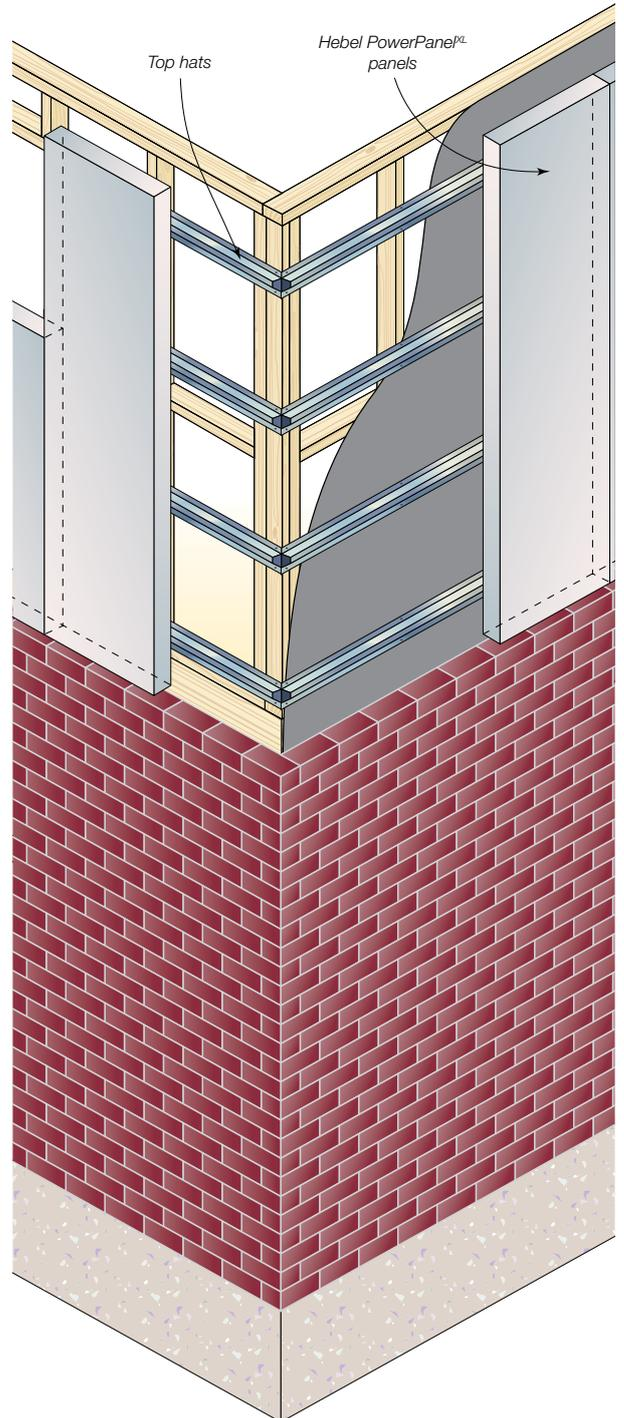


Figure 3.6.3.2 Two storey additions – typical section with brick veneer below

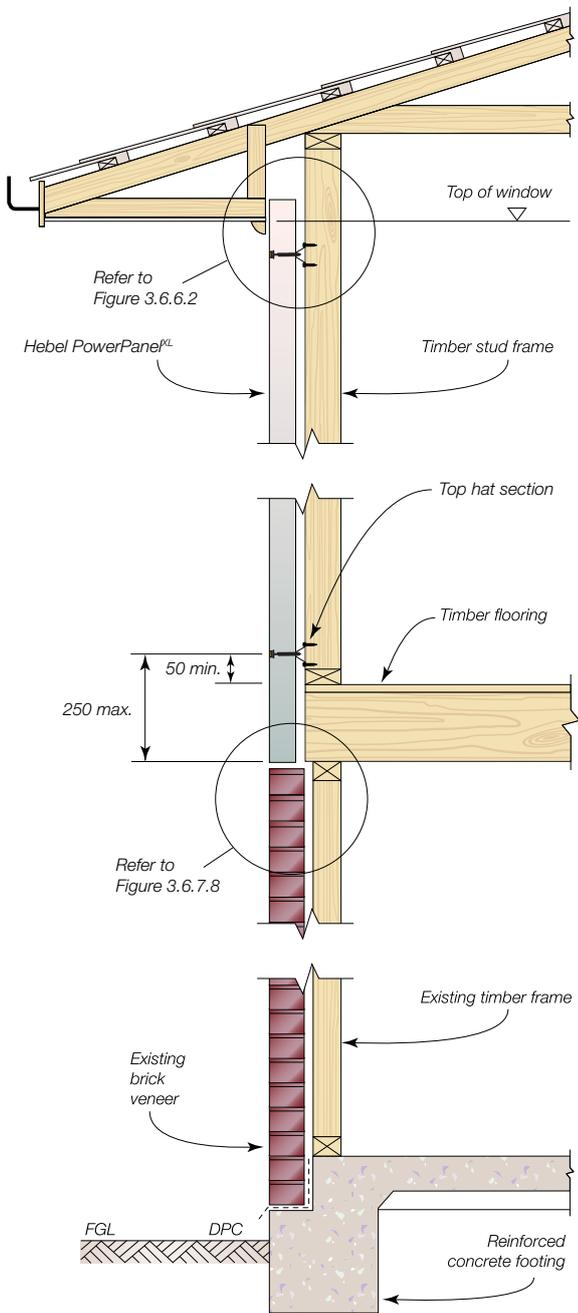
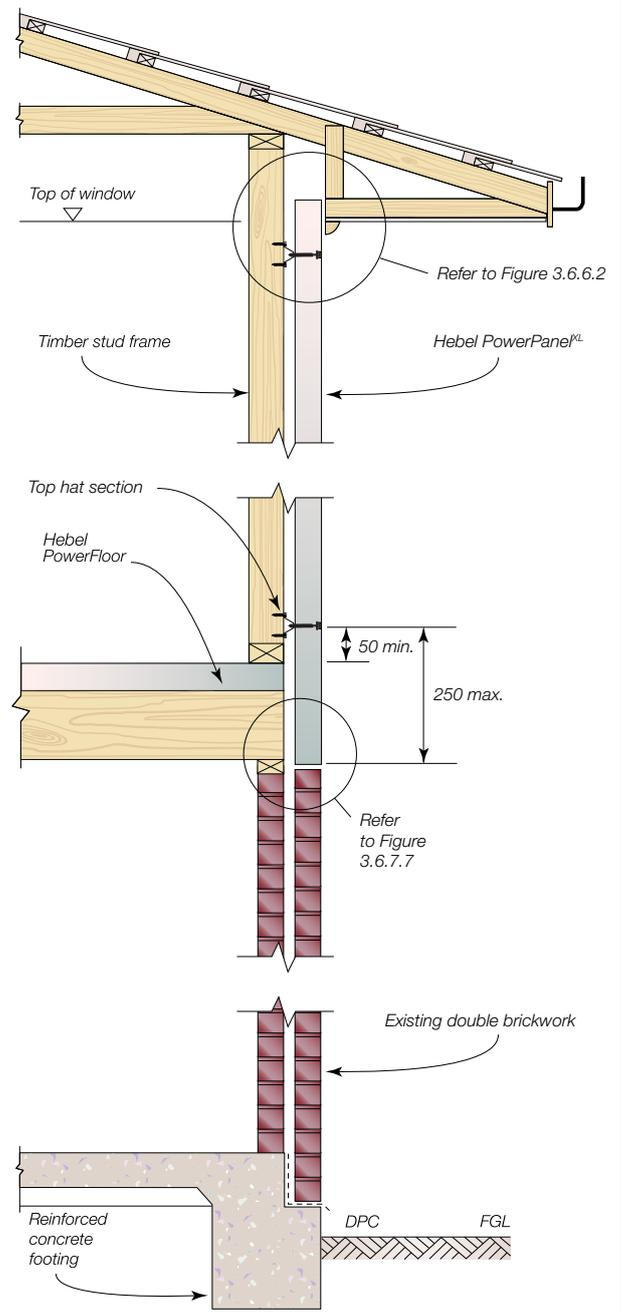


Figure 3.6.3.3 Two storey additions – typical section with double brick below

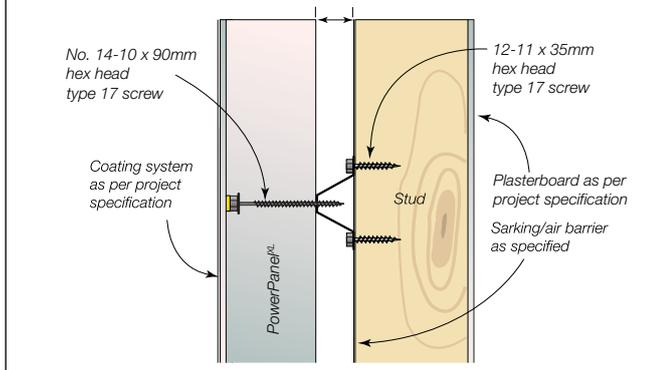


NOTES:

1. Minimum 4 top hats required for panels that are suspended off the frame. Refer to Table 1.2.4 of this guide.

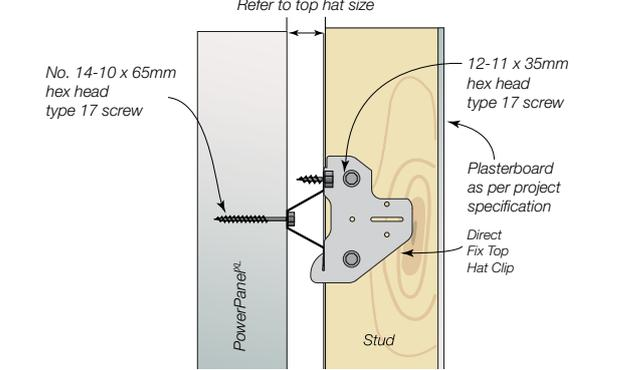
### 3.6.4 FIXING & INSTALLATION DETAILS

**Figure 3.6.4.1 Hebel PowerPanel<sup>XL</sup> External Wall System fixing detail (Achieves FRL 90/90/90 when installed as part of the wall system. See Section 2.2)**



**NOTE:**  
When positioning the stud frames allow 5-7mm extra cavity width for the sheet bracing between top hat and timber stud.

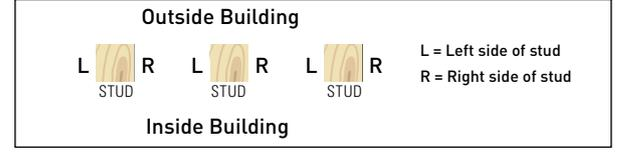
**Figure 3.6.4.2 Hebel PowerPanel<sup>XL</sup> Zero Boundary Wall System fixing detail (Achieves FRL 90/90/90 when installed as part of the wall system. See Section 2.2)**



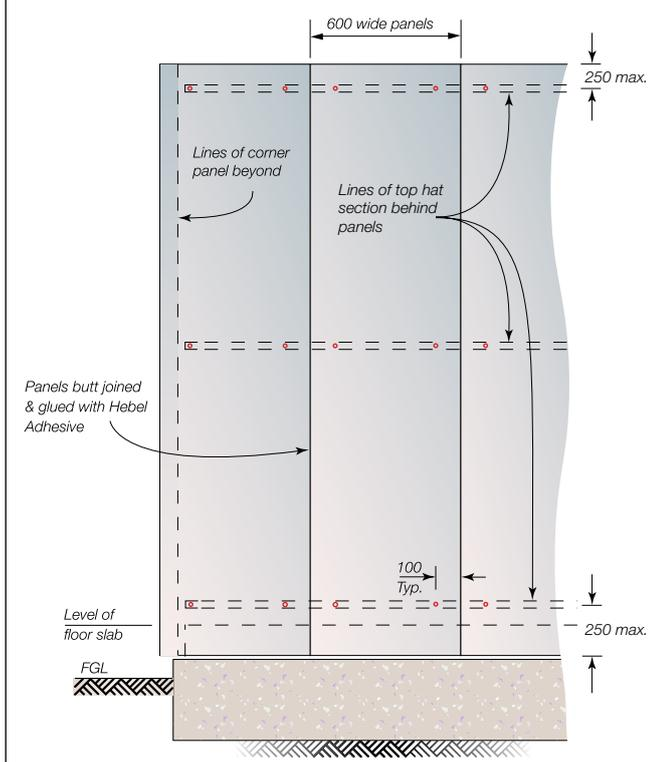
**IMPORTANT:** Top hat clip is fixed on the left hand side of the stud (when looking from inside to the outside of the building) except at the last stud, only, when the clip may be installed upside down.

Installing the clip upside down i.e where the screw fixing from the clip to the top hat is at the bottom flange of the top hat, will be acceptable provided that:

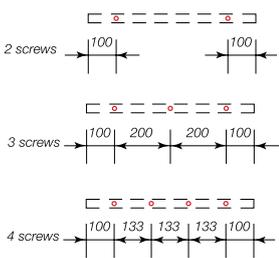
- A: The upside down clip is fixed on the right hand side of the stud (when looking from the inside to the outside of the building)
- B: The upside down clip installation is to the last stud of a wall run (only), such that the spacing between the last and second last studs is no greater than 600mm,
- C: The top hat is continuous in this region for a minimum of two spans i.e top hat extends across two stud spacings,
- D: In all other locations, clips are to be installed to the left hand side of the stud with the screw fixing to the top side of the clip i.e into the top flange of the horizontal top hat.



**Figure 3.6.4.3 Screw layout drawing**

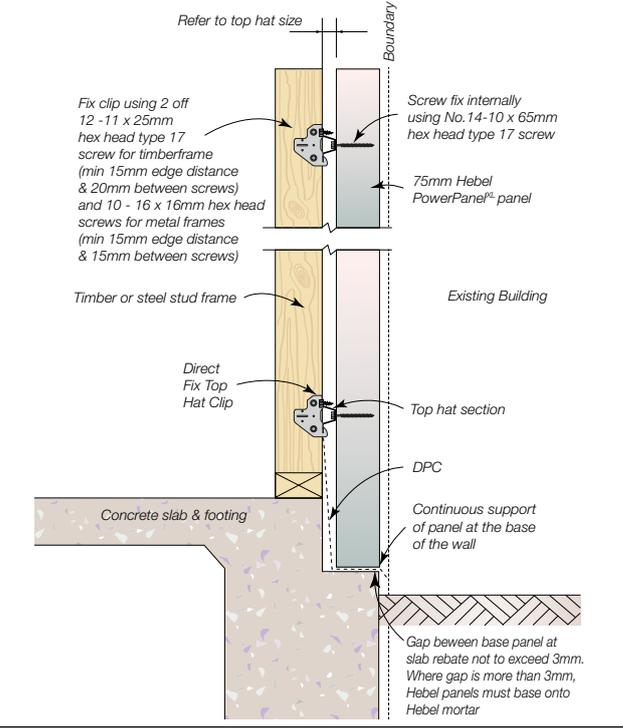


PowerPanel<sup>XL</sup> panel setout – elevation view



Screw layout

**Figure 3.6.4.4 Hebel PowerPanel<sup>XL</sup> zero Boundary Wall System (Achieves FRL 90/90/90 when installed as part of the wall system. See Section 2.2)**



### 3.6.5 FOOTING JUNCTION DETAILS

Figure 3.6.5.1 Junction to shallow concrete footing

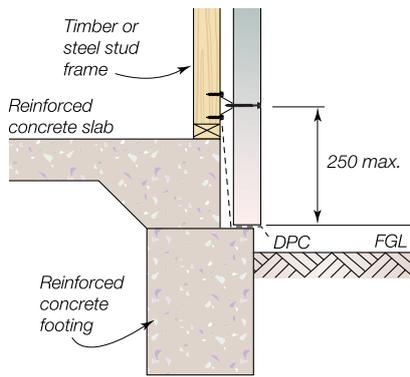


Figure 3.6.5.2 Junction to deep concrete edge beam

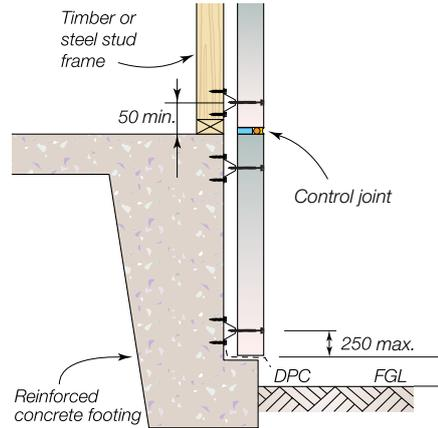


Figure 3.6.5.3 Junction to masonry earth retaining wall

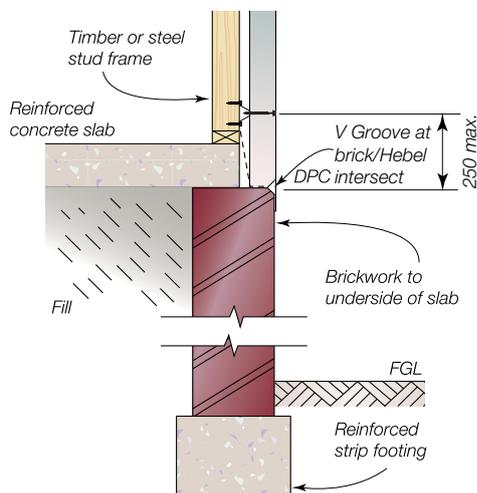
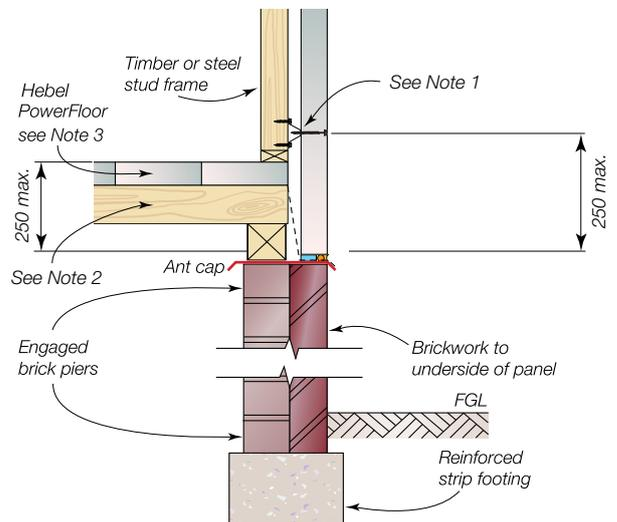


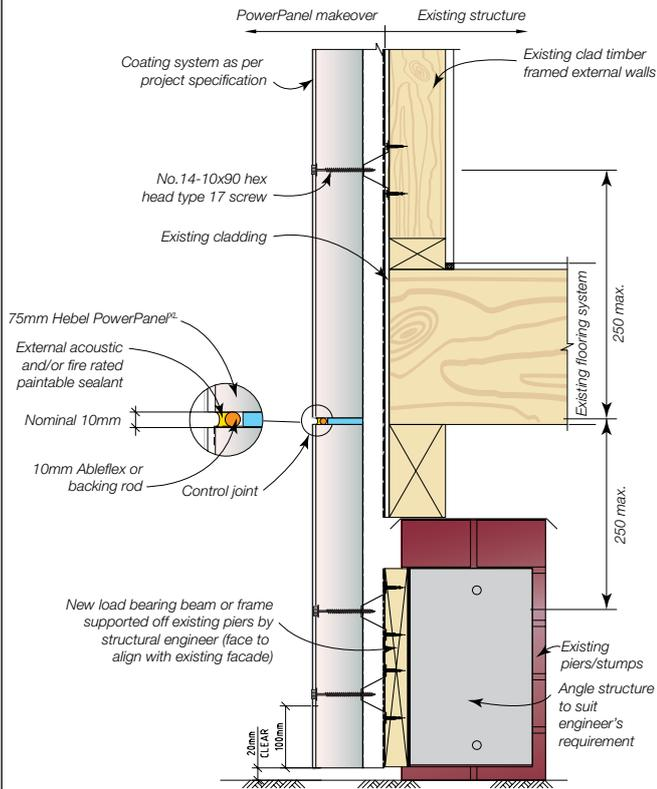
Figure 3.6.5.4 Junction to masonry dwarf wall



NOTES:

1. Do not fix top hat to floor joists.
2. If non-shrink floor joists are used, gap may be reduced or eliminated. Seek further technical advice from the framing manufacturer.
3. Refer to CSR Hebel for Hebel PowerFloor details.
4. Refer AS 3660 for termite protection.
5. When fixing top hats to concrete, contact the fixing manufacturer for details.
6. Refer to Table 1.2.6 for top hat requirements for deep concrete edge beam applications.

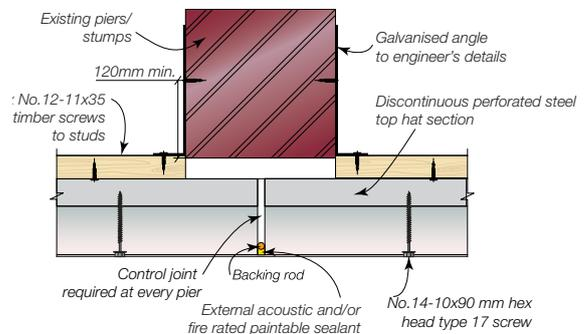
**Figure 3.6.5.5 Junction to existing piers/stumps**



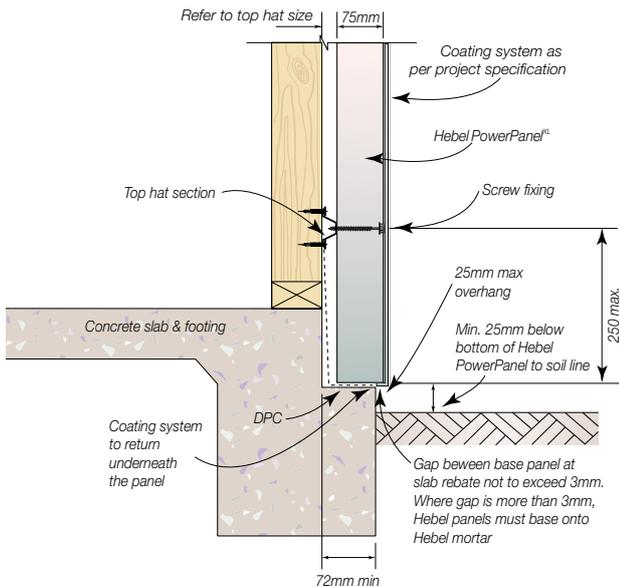
**NOTES:**

1. Refer to Tables 1.2.3 to 1.2.5 for top hat requirement for suspended applications
2. This detail is not considered to achieve a fire rating level
3. This slab edge detail does not comply with the termite visible inspection zone requirements. Alternate termite management systems must be used when selection this detail. It is the responsibility of the builder to provide a suitable physical or chemical barrier in accordance with AS 3660.

**Figure 3.6.5.6 Base detail suspended floor – pier connection**



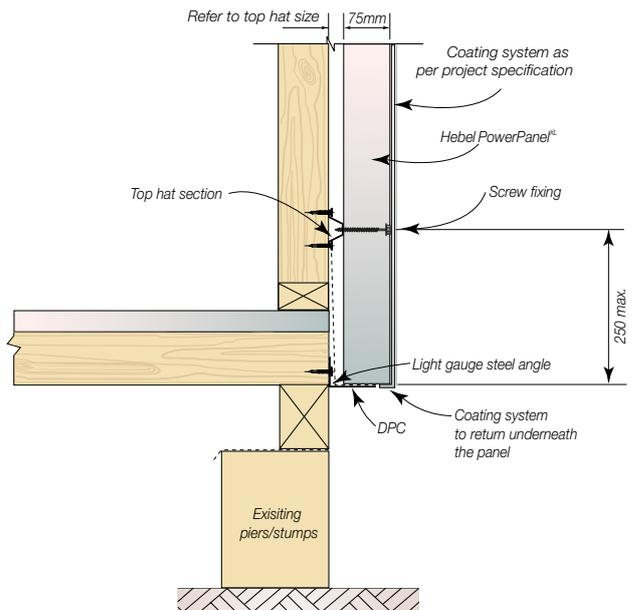
**Figure 3.6.5.7 Junction to shallow concrete edge beam (Achieves FRL 180/180/180 when installed as part of the wall system. See Section 2.2)**



**NOTES:**

1. All garden beds and/or finished soil line must remain a minimum of 25mm below the bottom of the finished rendered wall.
2. This slab edge detail does not comply with the termite visible inspection zone requirements. Alternate termite management systems must be used when selection this detail. It is the responsibility of the builder to provide a suitable physical or chemical barrier in accordance with AS 3660.

**Figure 3.6.5.8 Junction to steel angle**



**NOTES:**

1. This detail is not considered to achieve a fire rating level.
2. The light gauge steel angle is for the purpose of closing the cavity at the base of the wall.

Figure 3.6.5.9 Junction to Hebel below finish ground

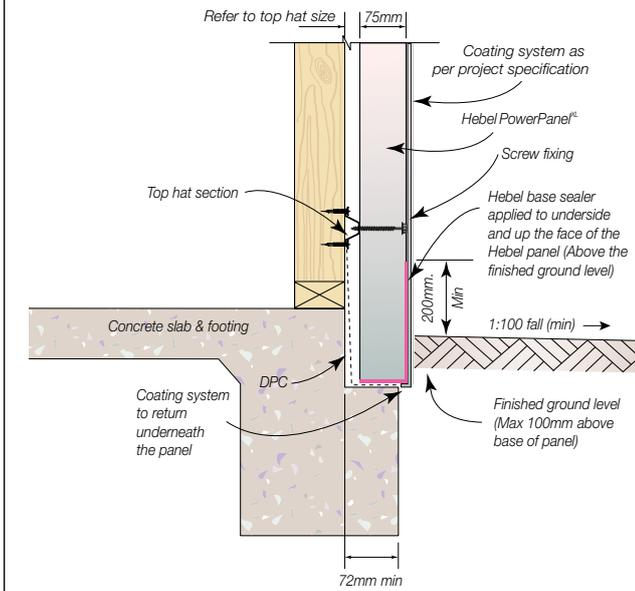
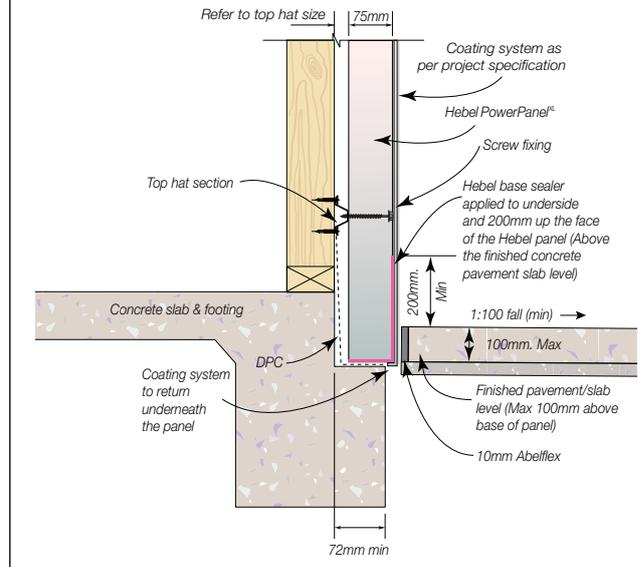


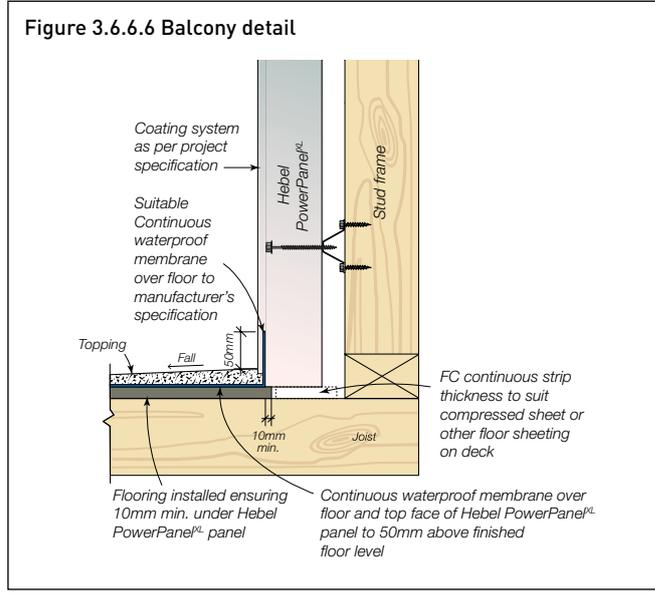
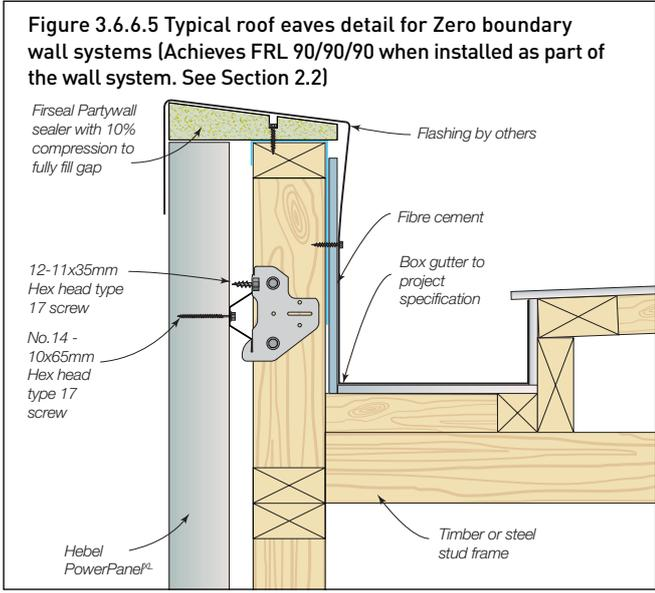
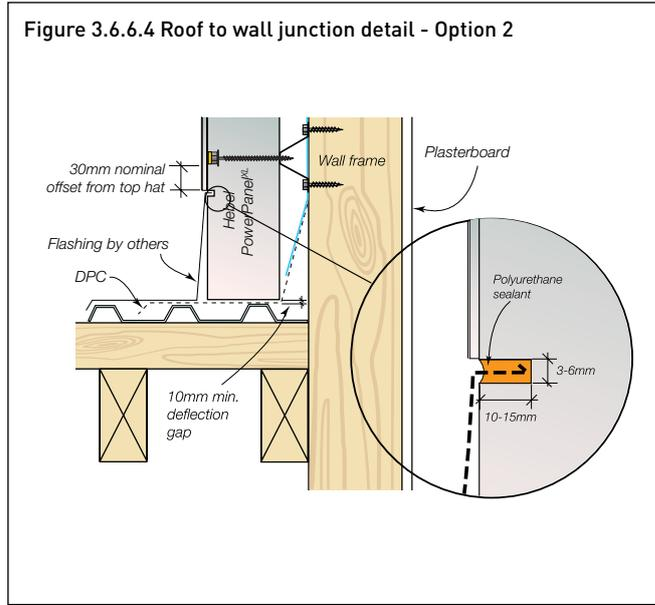
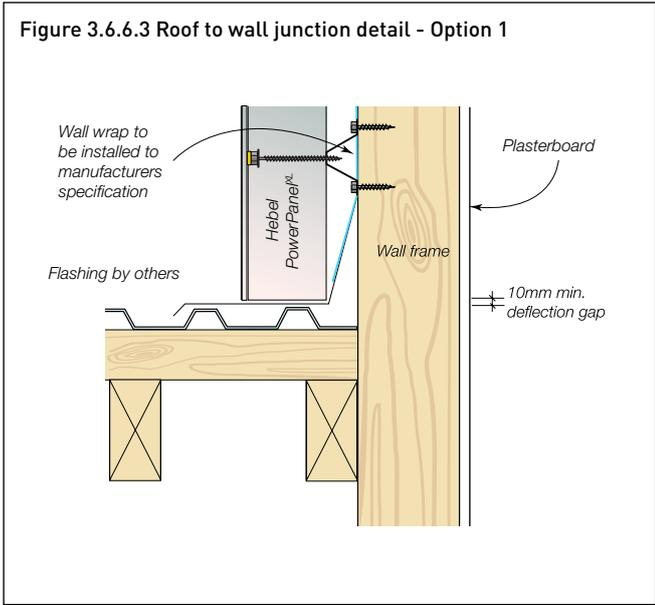
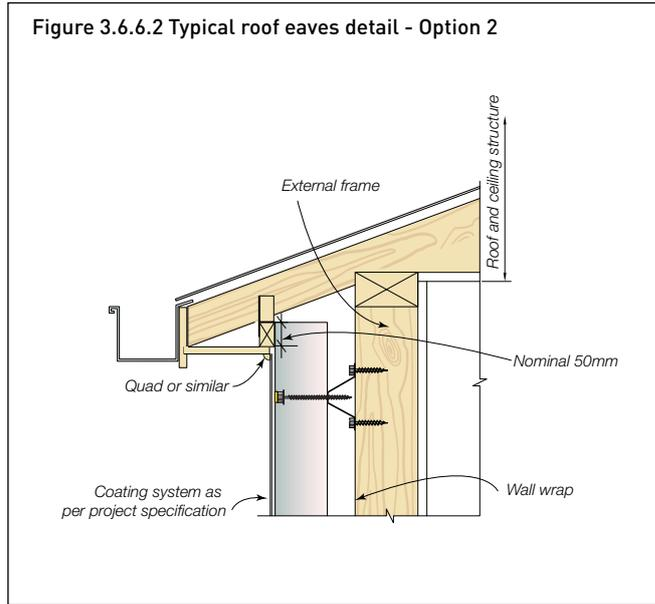
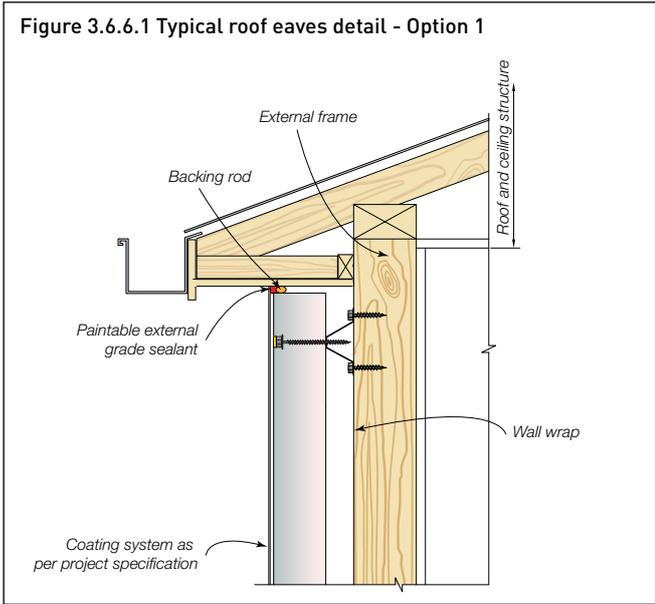
Figure 3.6.5.10 Junction to Hebel below concrete pavement slab



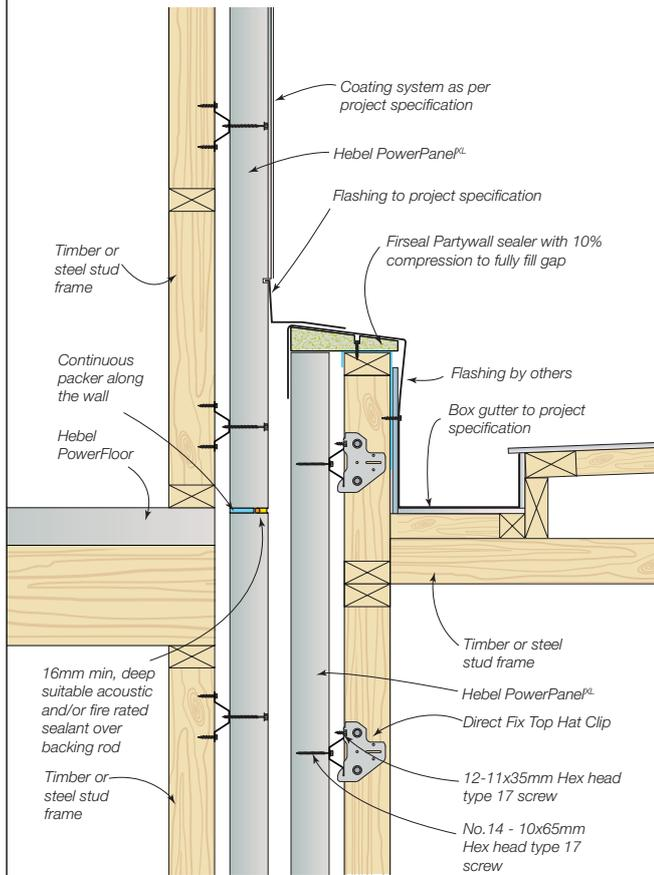
NOTES:

1. This slab edge detail does not comply with the termite visible inspection zone requirements. It is the responsibility of the builder to ensure chemical barrier in accordance with AS3660 is installed or other suitable termite protection system is adopted.
2. Hebel PowerPanel base must be coated with Hebel Base Sealer prior to installation.
3. Hebel Base Sealer to be applied min. 200mm above finished ground level.

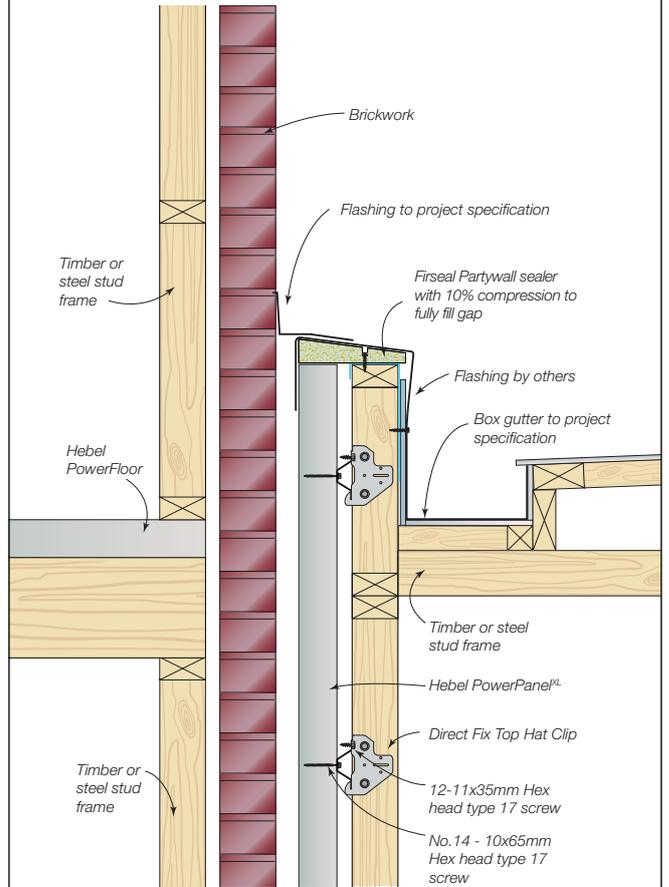
### 3.6.6 WALL JUNCTION DETAILS & SECTIONS



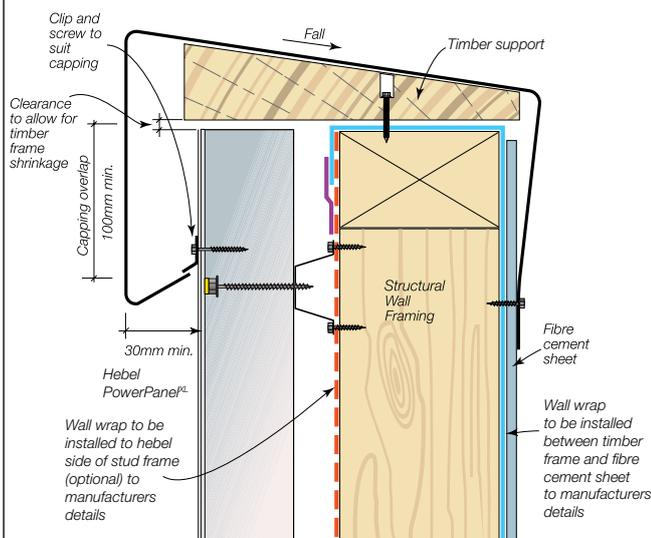
**Figure 3.6.6.7 Zero boundary wall detail to Hebel PowerPanel<sup>XL</sup> external wall system (Achieves FRL 90/90/90 when installed as part of the wall system. See Section 2.2)**



**Figure 3.6.6.8 Zero boundary wall detail to brick veneer (Achieves FRL 90/90/90 when installed as part of the wall system. See Section 2.2)**

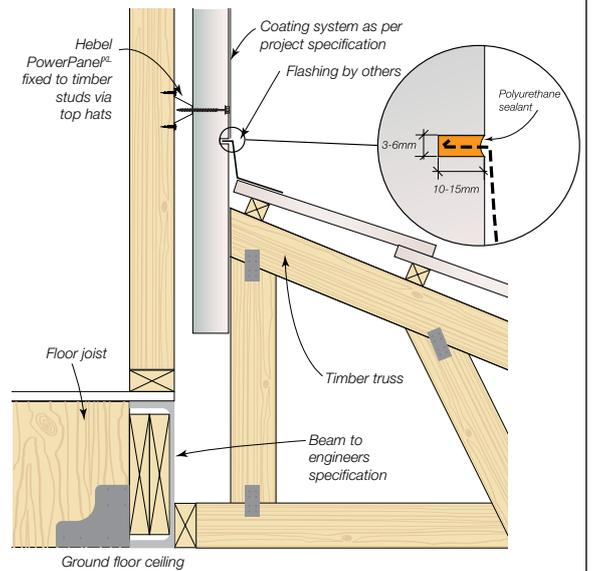


**Figure 3.6.6.9 Parapet capping**



**NOTE:**  
Parapet capping shall be designed and fastened in accordance with SAA – HB39 2015 – Installation Code for Metal Roofing and Wall Cladding. Stop ends shall be incorporated to all flashings.

**Figure 3.6.6.10 Hebel to pitched roof junction**



**NOTE:** Hebel PowerPanel<sup>XL</sup> panels are suspended from frame. Refer to tables 1.2.4 and 1.2.5 of this guide for design.

Figure 3.6.6.11 Gable end wall detail

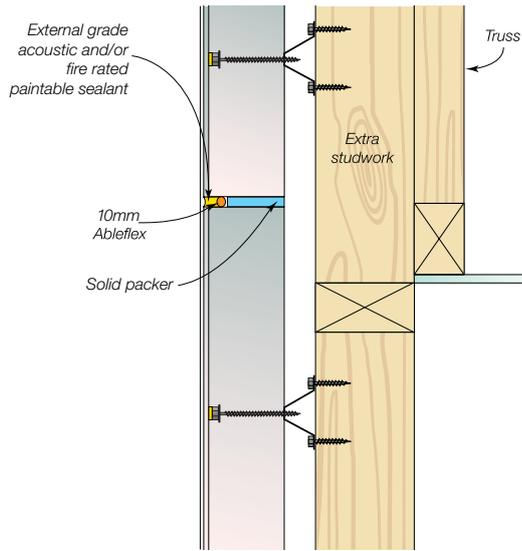


Figure 3.6.6.12 Gable end wall detail – lintel panel over window

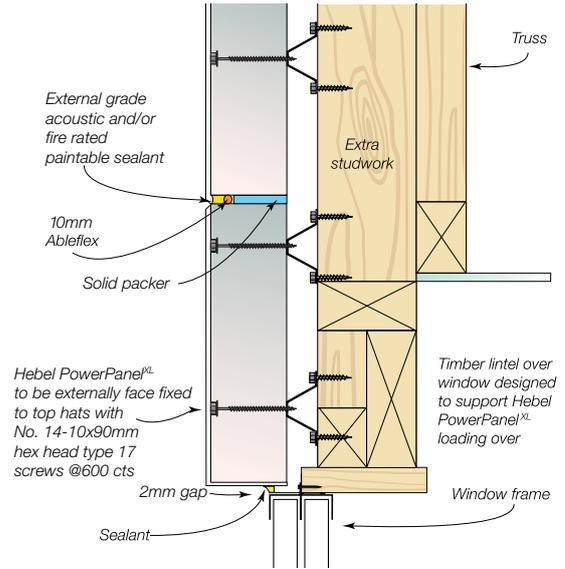


Figure 3.6.6.13 Beam penetration detail

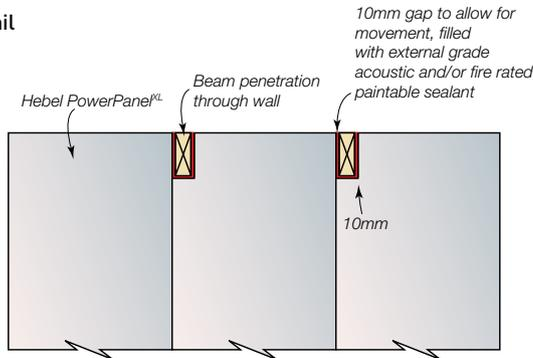
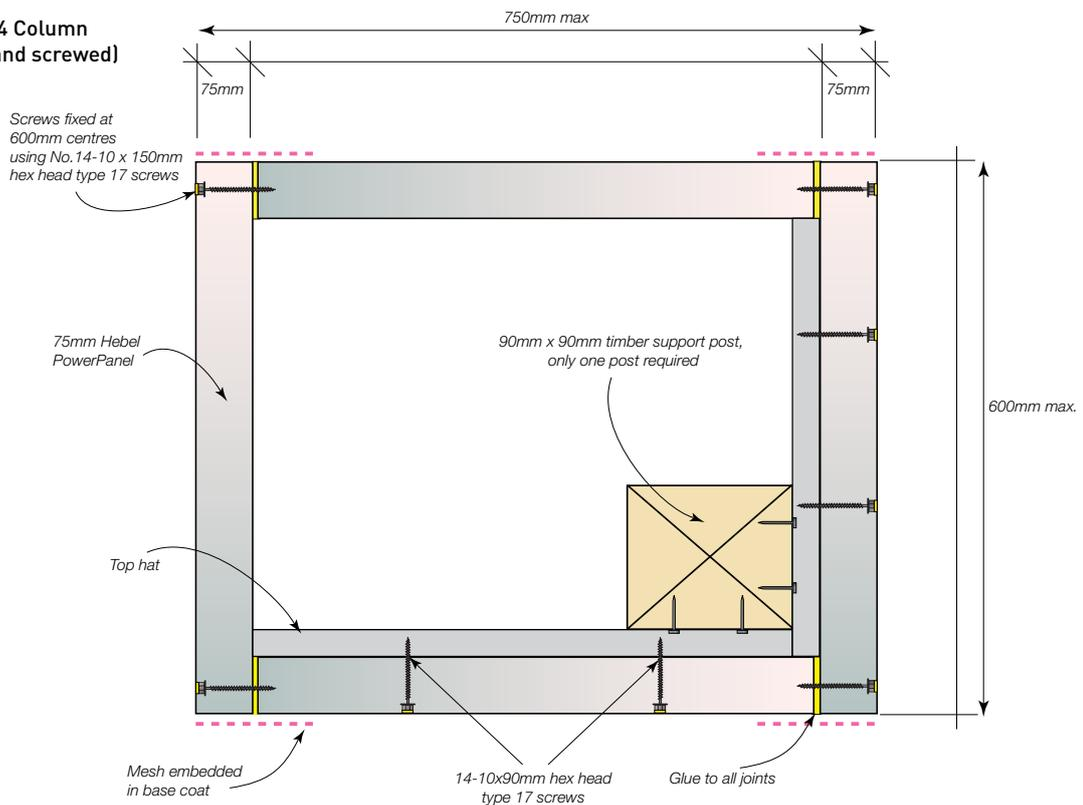


Figure 3.6.6.14 Column detail (glued and screwed)



### 3.6.7 CONTROL JOINTS

The following information provides the necessary rules for control jointing when installing the Hebel PowerPanel<sup>XL</sup> External Wall System:

- Refer section 1.3 for vertical control joint spacing (based on site classification)
- Vertical control joints required at external and internal corners
- Vertical control joints required above and below all doors, including sliding and garage doors
- Vertical control joints required at the position where a wall changes height by more than 20% e.g a vertical control joint is required when wall height changes from 2700mm to  $\geq 3240$ mm.
- Horizontal control joints required at every horizontal floor junction
- Horizontal control joints required at a maximum height of 3.9m.

#### For openings < 2450mm in width

- Control joint not required. If the straight joint that extends above or below the window jamb is less than 600mm long, a control joint or a glued and meshed joint is required.

#### For openings $\geq 2450$ mm and < 3600mm wide

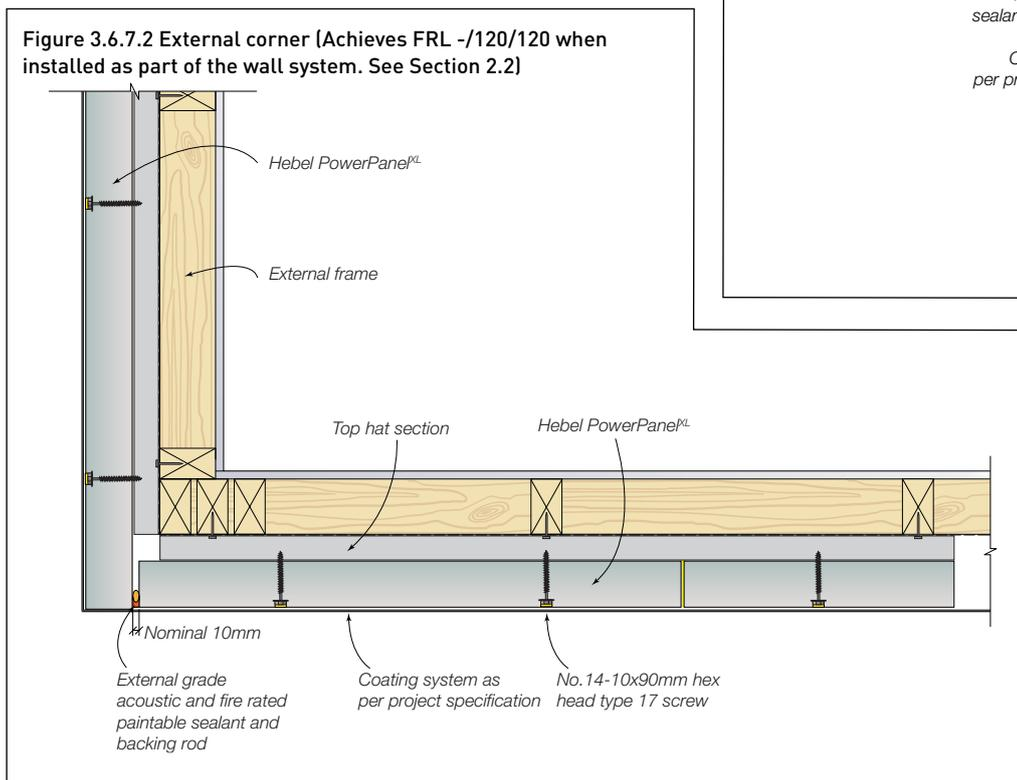
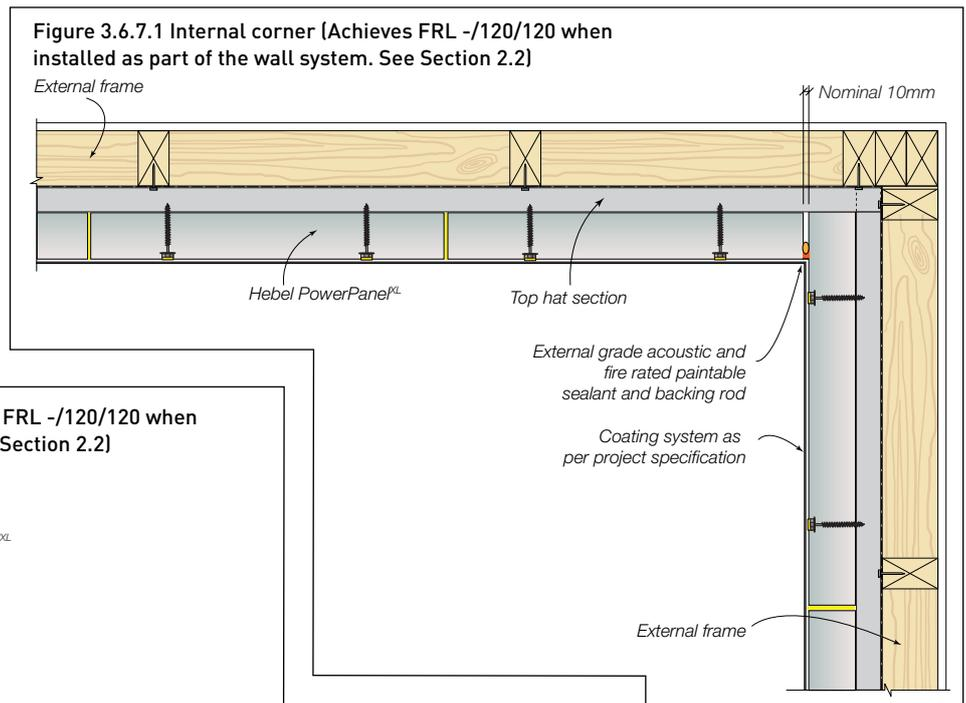
- Control joint required to at least one side of the opening (i.e. above and below the opening). If the straight joint that extends above or below the window jamb is less than 600mm long a control joint or a glued and meshed joint is required to the opposite side of the opening.

#### For openings $\geq 3600$ mm in width

- Control joint required to both sides of the opening (i.e. above and below the opening).

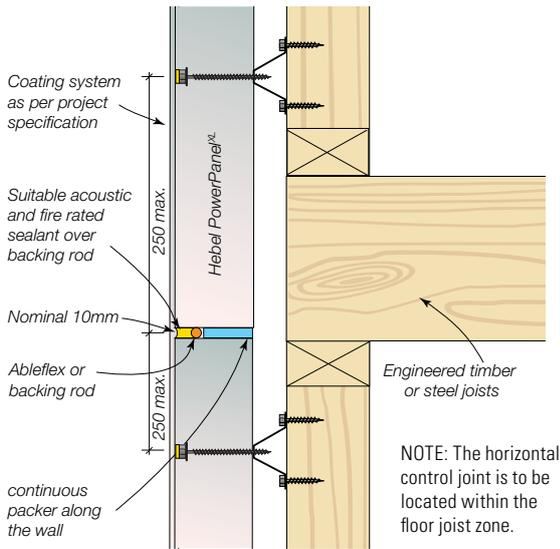
#### NOTES:

1. The minimum lintel panel height above windows is 270mm.
2. Footing and slab design to comply with AS 2870.
3. Vertical control joints are not required to align between storeys of the building and can be terminated at the horizontal control joint located within the upper storey floor framing structure zone/depth.
4. The PowerPanel<sup>XL</sup> panels can be installed directly beside window or door openings (retaining a minimum 2-3mm gap between window jamb and panel) such that the control joint is only installed above and below the opening to the required width, negating the need to provide the width of the control joint directly beside the window or door. The 2-3mm gap is also required at the head of the window or door to the head panel.

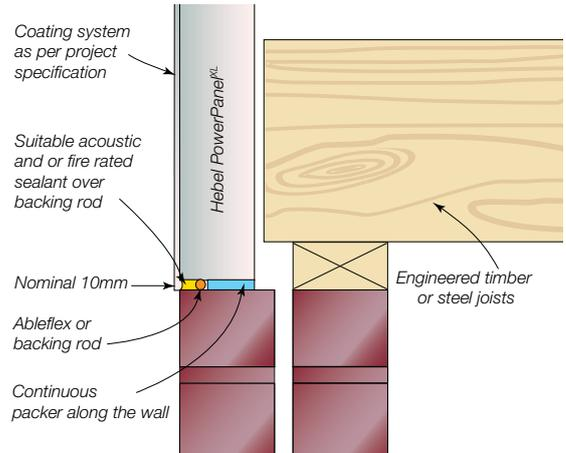




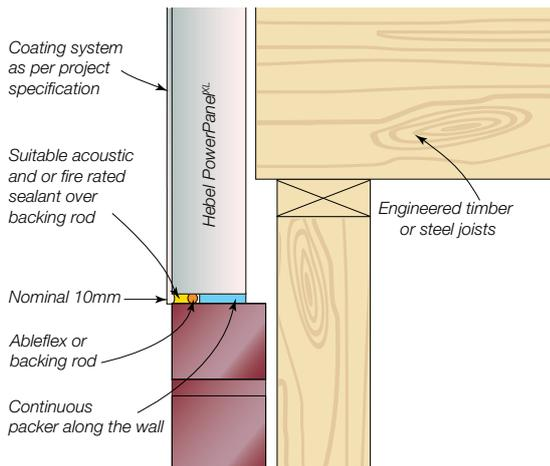
**Figure 3.6.7.5 Typical horizontal control joint – engineered timber or steel frame (Achieves FRL -/120/120 when installed as part of the wall system. See Section 2.2)**



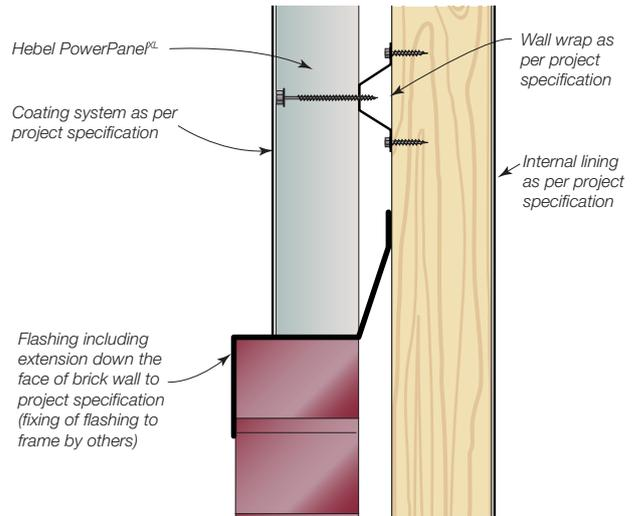
**Figure 3.6.7.6 Horizontal control joint – Cavity brickwork to Hebel PowerPanelXL**



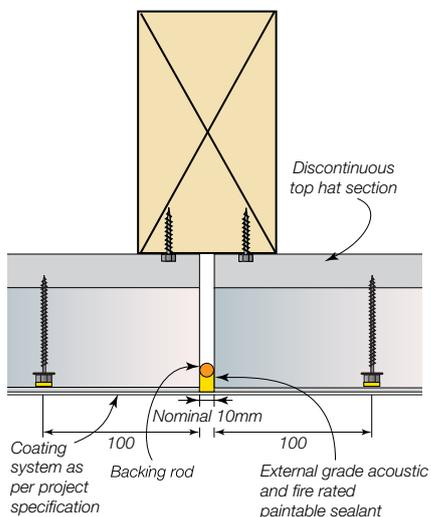
**Figure 3.6.7.7 Horizontal control joint – Brick veneer to Hebel PowerPanelXL - Option 1**



**Figure 3.6.7.8 Horizontal control joint – Brick veneer to Hebel PowerPanelXL - Option 2**



**Figure 3.6.7.9 Typical vertical control joint (Achieves FRL -/120/120 when installed as part of the wall system. See Section 2.2)**



**Figure 3.6.7.10 Typical vertical control joint with double studs (Achieves FRL -/120/120 when installed as part of the wall system. See Section 2.2)**

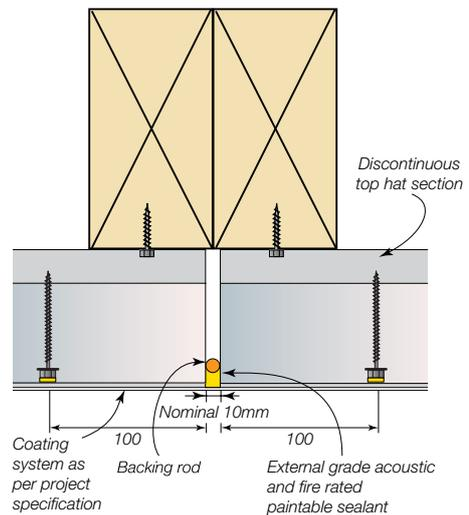


Figure 3.6.7.11 Control joint - aligned top hats on double stud

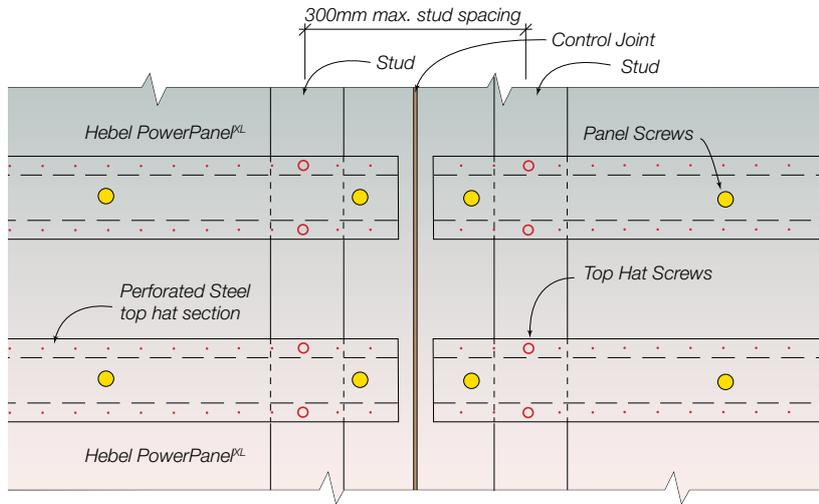


Figure 3.6.7.12 Control joint - discontinuous top hats on a single stud

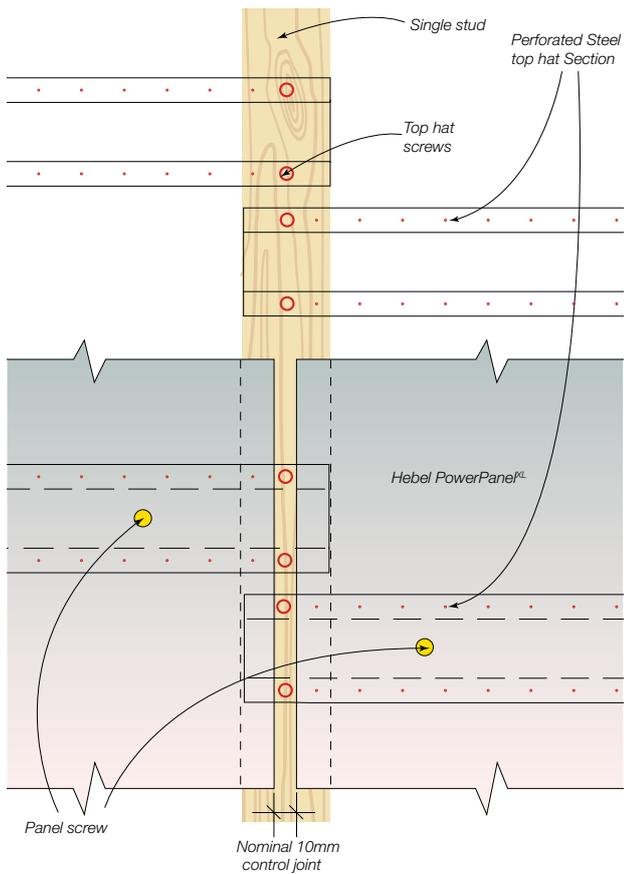
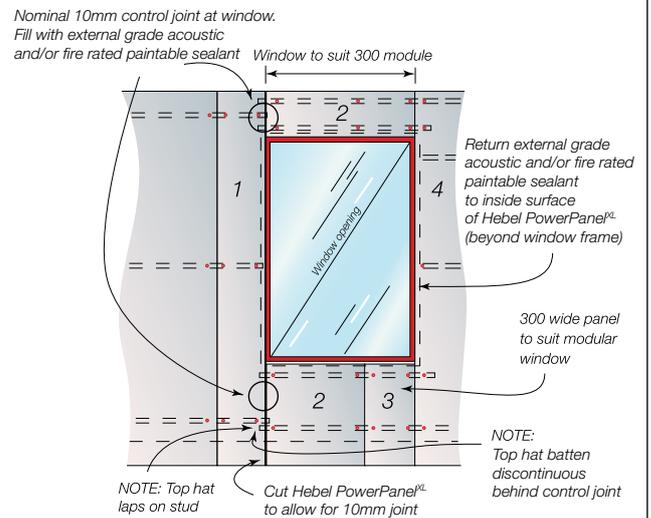
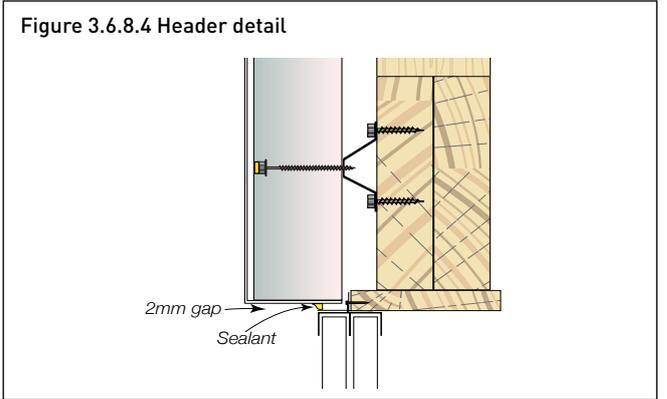
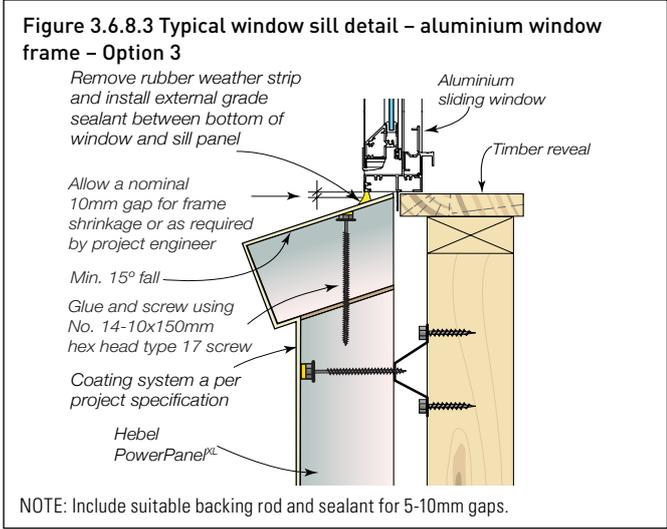
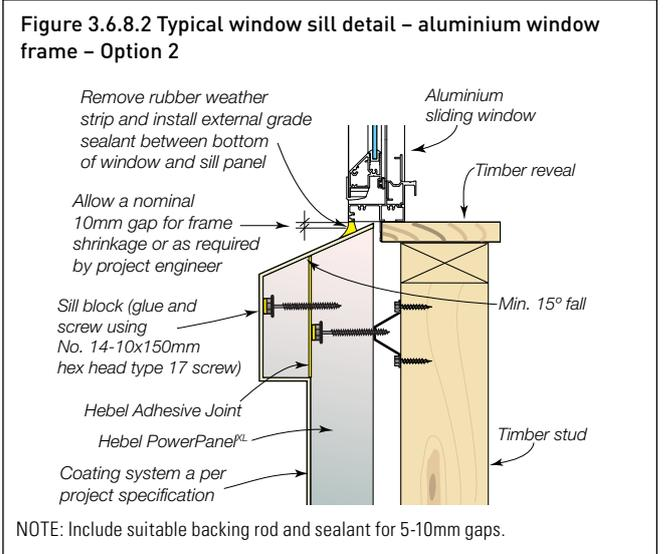
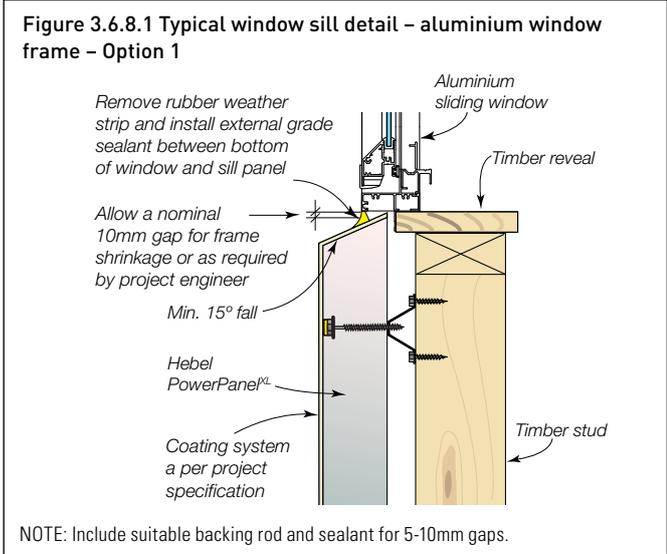


Figure 3.6.7.13 Typical window control joint detail - lintel over



NOTE:  
The installation sequence of the PowerPanel<sup>XL</sup> panels around the openings should be followed as numbered if there is no control joint at the opening, to maintain glue thickness on the edge of the panel.

### 3.6.8 DOOR & WINDOW DETAIL



NOTE: CSR Hebel recommends the removal of the rubber weather strip at the window sill prior to applying external grade sealant between the bottom of the window sill and panel. Windows shall be caulked around all sides to ensure that the system remains sealed and not allow water ingress into the cavity. The installation of any alternative details shall be the responsibility of the builder to provide supporting evidence that it meets the requirements of a sealed system and maintains a dry cavity.

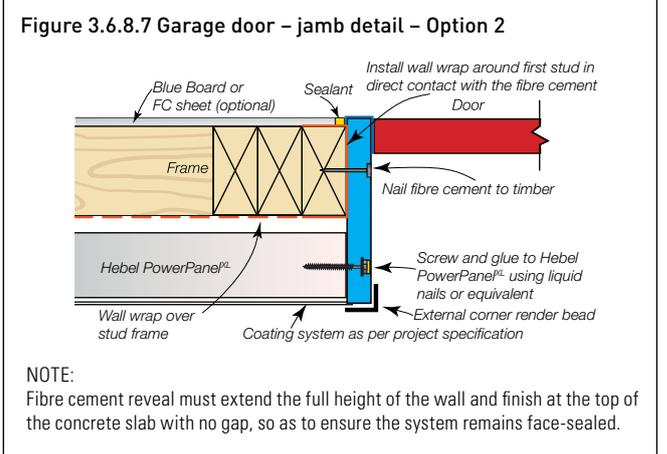
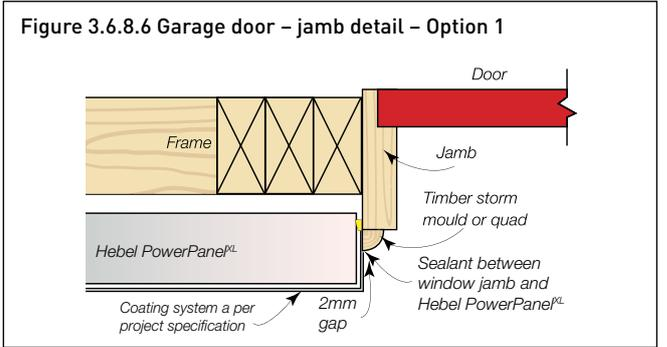
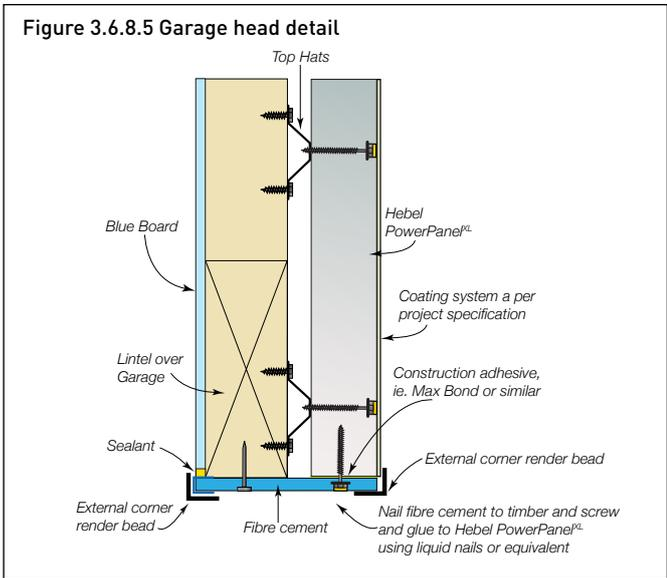


Figure 3.6.8.8 Sliding door sill detail – Concrete sill < 270mm

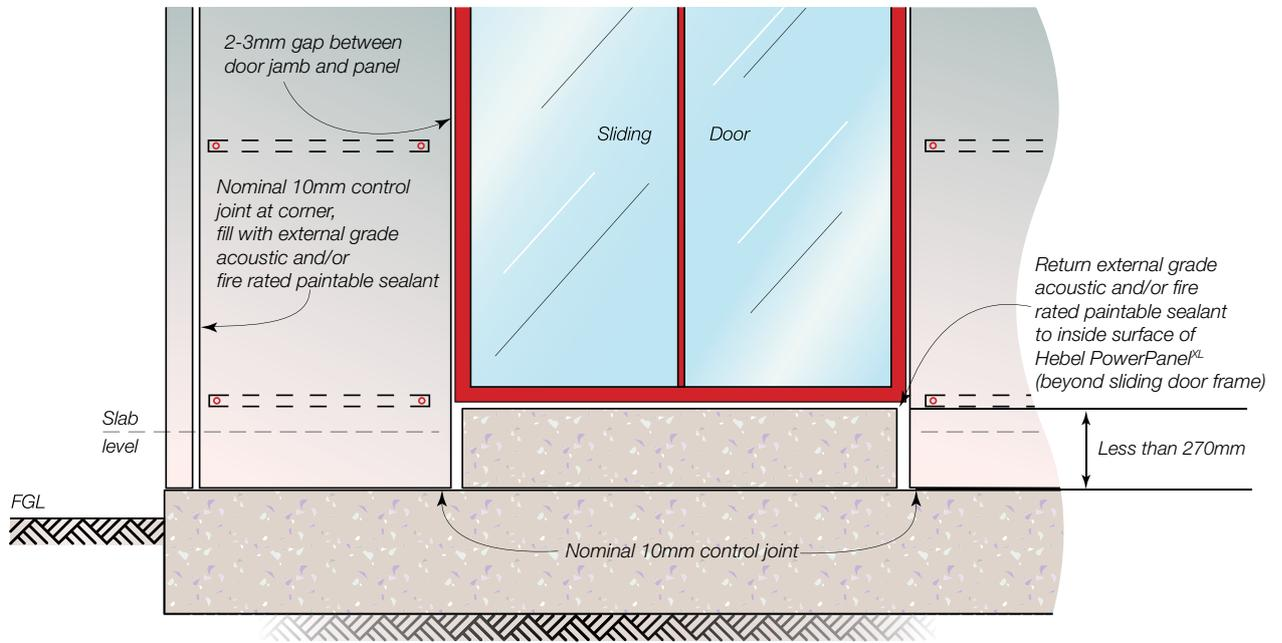
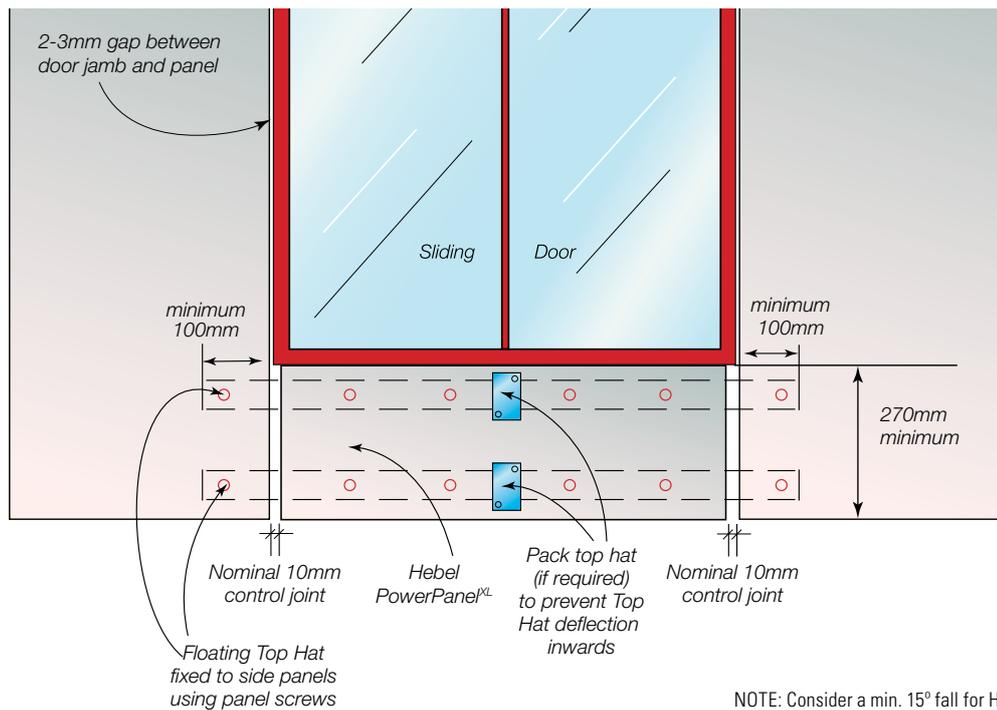


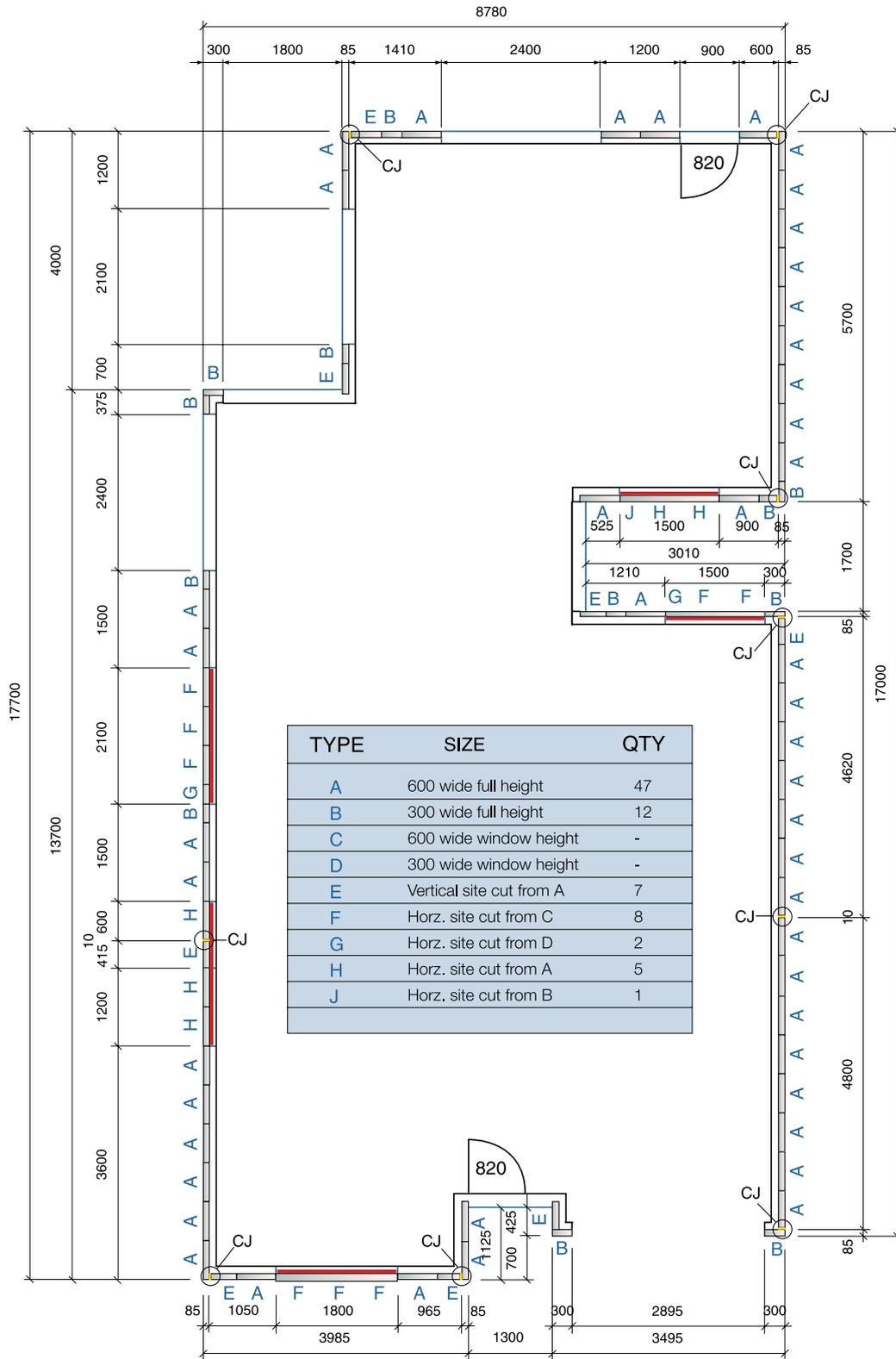
Figure 3.6.8.9 Sliding door sill detail – PowerPanel<sup>XL</sup> sill > 270mm



NOTE: Consider a min. 15° fall for Hebel door sill.

### 3.6.9 MISCELLANEOUS DETAIL

Figure 3.6.9.1 Panel layout drawing – Plan view



**NOTES:**

1. At corners, PowerPanelXL panels can be laid out at 300mm multiples in one direction and 300mm multiples + 85mm in the other direction
2. Width of PowerPanelXL panels may vary + or - 1.5mm

# 4.1 DELIVERY AND STORAGE

## UNLOADING PANELS

Panels must be unloaded and moved with only approved lifting devices. Before use, the lifting devices should be checked for the required lifting tags. Panels should be unloaded as close as possible to the intended installation area. This will increase work efficiency and minimise the need for secondary lifting.

NOTE: Secondary handling increases the risk of panel damage. The repair of damage sustained during lifting and moving is the responsibility of the lifter. Where damage is excessive, panels must be replaced.

## STORAGE

All materials should be kept dry and preferably stored undercover. Care should be taken to avoid sagging or damage to ends, edges and surfaces.

All Hebel products must be stacked on edge and properly supported off the ground, on a level platform. Panel bundles can be stacked two high.

The project engineer should be consulted as to the adequacy of the structure to support the stacked bundles. Each bundle contains ten PowerPanels. Where bundles are stacked two high the supporting cleats must be vertically aligned to ensure minimal bending of the lower panels. (see Figure 4.1.1). If Hebel PowerPanels are stored outside they must be stored off the ground and protected from the weather.

To provide a level surface we recommend placing temporary joists beneath the supporting cleats.

## UNSTRAPPING PACKS

Ensure appropriate bracing is installed to packs prior to removal of strapping to prevent panels from falling. Panels can be held together with sash clamps, ratchet, straps or Hebel stabilising bars.

### SAFE STACKING OF HEBEL

Figure 4.1.1 Stacking bundles of Hebel PowerPanel

- NEVER stack strapped panels more than two packs high.
- Brace all unstrapped panels – timber bracing can be used with 100mm screws
- NEVER place panels on council strips/footpaths or public access area
- ALWAYS check safe loadbearing weight when storing packs on structures

Note: Secondary handling increases the risk of panel damage. The repair of damage sustained during lifting and moving is the responsibility of the lifter. Where damage is excessive, panels must be replaced.

# 4.2 PANEL HANDLING

## PANEL HANDLING

Hebel recommends using a trolley or other mechanical apparatus to move the panels around the work site. Manual handling where people physically move a panel should be kept to a minimum, with the weight being supported by an individual kept as small as possible. Any concerns regarding the weight to be handled should be discussed with the panel installation contractor.

To minimise the possibility of manual handling injuries, Hebel suggests the following:

- Use mechanical aids, such as trolleys, forklifts, cranes and levers, or team lifting to move panels.
- Keep the work place clean to reduce the risk of slips, trips and falls, which can cause injury.
- Plan the sequence of installation to minimise panel movements and avoid awkward lifts.
- Train employees in good lifting techniques to minimise the risk of injury.
- Storage and handling of Hebel PowerPanel must be in accordance with the recommendations of CSR to ensure the safety of workers on site. The panels are only to be lifted on edge and not to be handled flat. When storing, the panel orientation must be horizontal with the long edge supported on timber bearers.

It is important to handle and store the panels as recommended above to ensure no overstress will occur.

Figure 4.2.1 Hebel Panel Lifters are used for positioning panel in wall.



Figure 4.2.2 Hebel Panel Trolleys for easier and safer handling and cutting of Hebel PowerPanels.

## HEBEL HOIST

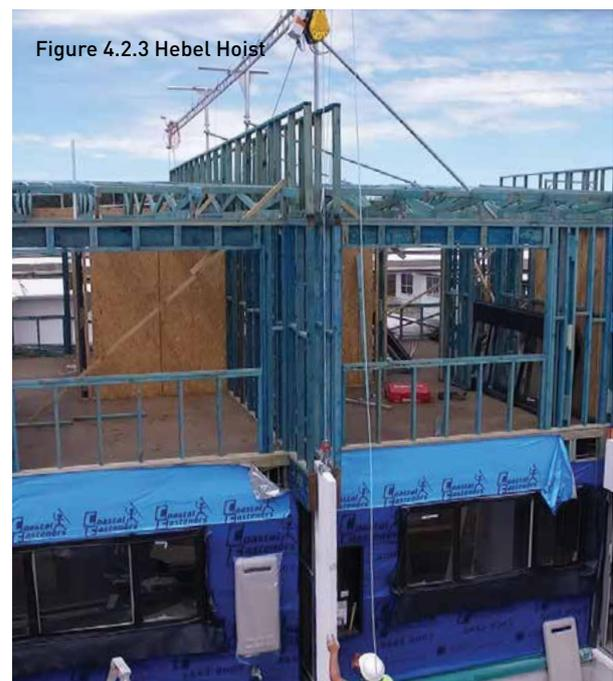
Building back-to-back compliant zero boundary walls on site has been largely unachievable using traditional techniques. The difficulty includes ensuring that the walls are positioned correctly without overstepping their boundaries and that the installation techniques adopted do not in any way compromise fire performance of these walls.

Due to these issues and others such as ensuring that acoustic performance (as a minimum) achieves similar performance as that required of intertenancy walls, CSR Hebel has developed an innovative hoisting solution that now makes it easy to install boundary walls and vastly improves the efficiency of installing intertenancy walls in areas with limited access.

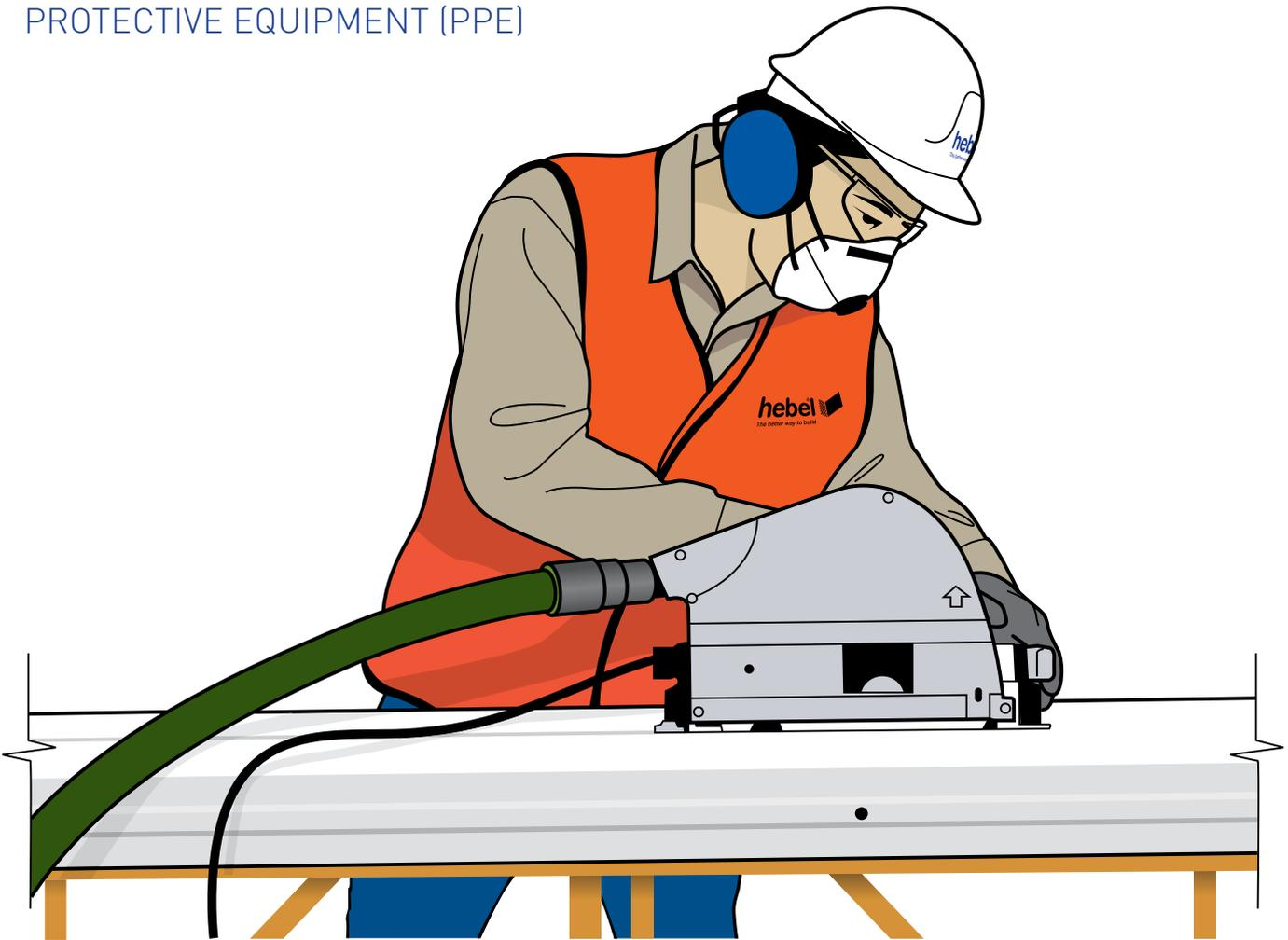
This revolutionary patented lifting device attaches directly to the frame and features a rail and hoist which allows panels to be safely lifted, transported and placed precisely from above before being fixed from the inside of the building.

Suitable for steel or timber frames up to three storeys high, the Hebel Hoist allows builders to streamline their workflow by erecting all the frames first before installing the external panels. It also has the potential to allow builders to increase the footprint of their buildings by moving external walls right up to the boundary.

The Hebel Hoist is only available through trained and accredited Hebel installers. Please contact your local CSR Hebel sales representative or the Hebel customer service centre to discuss the opportunity to improve your efficiency and profitability using Hebel Hoist.



## HEALTH, SAFETY & PERSONAL PROTECTIVE EQUIPMENT (PPE)



Use PPE gloves and wear suitable clothing when handling Hebel panels and blocks. Hebel products are cement-based, and though the dust is not absorbed through the skin it may cause irritation – particularly in association with heat and sweat. Repeated heavy contact with the dust can result in skin rash, called dermatitis, which typically affects the hands. To minimise exposure to dust on your skin we recommend wearing gloves (standard duty leather or equivalent AS 2161).

Dust from cement-based products is irritating to the eyes, causing watering and redness with the potential to aggravate certain eye conditions. When cutting, sawing, abrading, chasing or crushing Hebel panels or blocks we advise you to wear safety glasses with side shields or safety goggles (AS 1336) or a face shield.

Approved respirators (AS/NZS 1715 and AS/NZS 1716) and eye protection (AS 1336) should be worn at all times when cutting and chasing.



## CUTTING

The use of power tools when cutting concrete products may cause dust, which contains respirable crystalline silica, with the potential to cause bronchitis, silicosis and lung cancer after repeated and prolonged exposure without using the correct equipment and PPE.

### Follow these recommendations when cutting Hebel AAC

#### Wet Cutting

- Wet cutting provides the lowest airborne concentration levels.
- Cut in an outdoor environment or a well-ventilated cutting room (with air movement of between 500 and 1000 m<sup>3</sup>/h).
- Use a circular saw with a retrofitted attachment with continuous water applied to the cutting surface and blade.
- Worker must be clean shaven and wear a fit tested P2 mask.
- Refer clean-up process below.

#### Dry Cutting - Dust Extraction

- Cut in outdoor environment or well-ventilated cutting room (with air movement of between 500 and 1000 m<sup>3</sup>/h).
- Plunge saw or circular saw (enclosed blade is preferred) fitted with on-tool dust extraction, M or H Class industrial vacuum.
- Cut 2-5mm from full thickness of panel and support with cutting board in place (cutting board prevents escape of any residual dust).
- Stand on the enclosed side of the saw shroud and upwind.
- Worker must be clean shaven and wear a fit tested P2 mask.

### NO Controls = NO CUTTING

DO NOT CUT in uncontrolled cutting environments as exposure limits will be exceeded

- DO NOT dry cut without on tool local exhaust ventilation extraction.
- DO NOT cut with on tool extraction in an enclosed space without mechanical ventilation.
- DO NOT cut as P2 mask DOES NOT provide adequate protection, even when fit tested and clean shave. P2 mask must be used in conjunction with wet cutting or dust extraction/dry cutting method.
- DO NOT dry sweep.

Note: Steel reinforcement exposed during cutting must be coated with a liberal application of Hebel Anti-Corrosion Protection Paint.

## CLEANING – AVOID THE GENERATION OF DUST

- Wet cutting - slurry must be mixed with a quarter of a bag of Hebel Adhesive to harden before disposal in trade waste.
- Place waste in a sealed bag or container and dispose as trade waste.
- Dust extraction – vacuum bag is sealed (double bag for additional safety) and safely disposed of with trade waste.
- Use vacuum system with class M or H HEPA filter fitted to clean up where required.
- Avoid dust creation (e.g. by wet sweeping).
- Worker must be clean shaven and wear a fit tested P2 mask.



Refer to the Hebel Safety Data Sheets for further information regarding health and safety.

[www.hebel.com.au](http://www.hebel.com.au)

<https://hebel.com.au/working-safely-hebel/>

# 4.3 DESIGN, DETAILING AND PERFORMANCE RESPONSIBILITIES

Hebel engages independent testing laboratories to test and report on the performance of a wall in accordance with the relevant Australian Standards. Consultants use these reports as the basis for opinions (estimates of laboratory performance) they issue for variations or different arrangements to the tested system, and also to design and specify walls that meet appropriate criteria for a particular project. Using their experience, the consultant will make judgement about on-site installed performance of various walls. The performance levels of walls documented in this guide are either what is reported in a test or the documented opinion of consultants. Performance in projects is typically the responsibility of:

## PROJECT CONSULTANTS (STRUCTURAL, FIRE, ACOUSTIC, ETC.)

These consultants are typically responsible for the following:

- Opinions on expected laboratory performance of wall configurations that vary from actual test configuration, such as substitution products and components
- Judgements about expected field performance using laboratory test reports and practical experience
- Design, specification and certification of structural, fire, acoustic, durability, weather tightness and any other required performance criteria for individual projects

This involves the design and selection of building elements, such as wall and floors and their integration into the building considering the following:

- Interface of different building elements and to the structure / substrate
- Wall and floor junctions
- Penetrations
- Flashing issues
- Room / building geometry
- Acoustic and water penetration field-testing.

## PROJECT CERTIFIER AND/OR BUILDER

These professionals are typically responsible for:

- Identifying the performance requirements for the project in accordance with the National Construction Code and clearly communicating this to the relevant parties.
- Applicability of any performance characteristics supplied by Hebel including test and opinions for the project.
- The project consultant's responsibilities detailed above if one is not engaged in the project.

Hebel does not provide consulting services. Hebel only provides information that has been prepared by others and therefore shall not be considered experts in the field.

Any party using the information contained in this guide or supplied by Hebel in the course of a project must satisfy themselves that it is true, current and appropriate for the application, consequently accepting responsibility for its use.

It is the responsibility of the architectural designer and engineering parties to ensure that the details in this design guide are appropriate for the intended application.

The recommendations in this guide are formulated along the lines of good building practice, but are not intended to be an exhaustive statement of all relevant data.

Hebel is not responsible for the performance of constructed walls, including field performance, and does not interpret or make judgements about performance requirements in the NCC.

# APPENDIX A: HEBEL POWERPANEL<sup>XL</sup> MATERIAL PROPERTIES

## A.1 Manufacturing tolerances

Length	±5mm
Width	±1.5mm
Thickness	±1.5mm
Diagonals (max.)	5mm
Edge Straightness Deviation (max.)	1.5mm

## A.2 PowerPanel<sup>XL</sup> physical properties

- Hebel PowerPanel<sup>XL</sup> profile and nominal dimensions are shown in Section 1.4.
- Panel reinforcement is a single layer of steel mesh with 4 longitudinal wires of 4mm diameter.
- Nominal dry density = 400 kg/m<sup>3</sup>.
- Average working density = 540 kg/m<sup>3</sup> at 35% moisture content.
- Average service life density = 440 kg/m<sup>3</sup> at 10% moisture content.
- Hebel PowerPanel<sup>XL</sup> is manufactured in a range of stock sizes as detailed below:

Panel weight (kg)		
Length (mm)	Width (mm)	Weight (kg) at 35% M.C.
2400	600	58
2550	600	62
2700	600	66
2800	600	68
2850	600	69
3000	600	73
3300	600	80

NOTE: 75mm PowerPanel 1200 x 600mm weight 37kg.  
75mm PowerPanel 1800 x 600mm weight 56kg.

## A.3 PowerPanel<sup>XL</sup> strength properties

- Characteristic Compressive Strength or AAC,  $f'_{m} = 2.38$  MPa.
- Average Compressive Strength of AAC = 2.8 MPa.
- Characteristic Modulus of Rupture,  $f'_{ut} = 0.40$  MPa.

## A.4 PowerPanel<sup>XL</sup> acoustic properties

- Panel only with no plasterboard or other lining  
 $R_w = 34$ dB,  $R_w + C_{tr} = 30$ dB (refer to Acoustic Logic Test Report ref: 2010861.15/2602A/R2 GW).

## A.5 PowerPanel<sup>XL</sup> thermal properties

- R-Value of PowerPanel<sup>XL</sup> with no plasterboard or other lining = 0.6 m<sup>2</sup>.K/W (4% moisture content).

## A.6 Fire hazard indices

Hebel products have BCA Group Number 1 and also the following early fire hazard indices, determined in accordance with AS1530.3:1999:

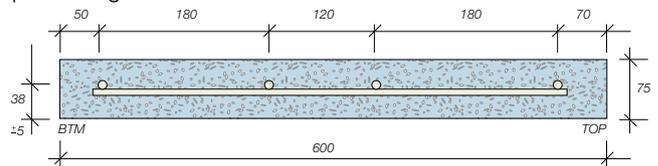
Ignitability Index	0
Spread of Flame Index	0
Heat Development Index	0
Smoke Development Index	0-1

## A.7 Fire Resistance Level (FRL) Ratings

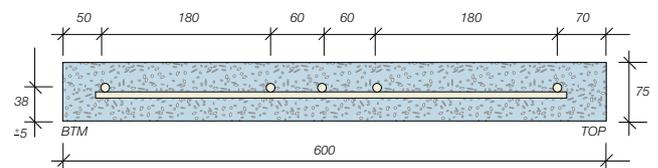
For fire performance characteristics of Hebel PowerPanel<sup>XL</sup>, refer to Section 2.2 of this guide.

## A.8 Typical Hebel PowerPanel<sup>XL</sup> cross section

Typical Hebel Powerpanel<sup>XL</sup> cross section for 2400 - 3000mm panel length:



Typical Hebel Powerpanel<sup>XL</sup> cross section for 3300mm panel length:



### NOTES:

1. BTM: To locate the approximate location of reinforcing the smooth edge of the panel is the bottom (BTM).
2. Bars: 4x4mm  $\emptyset$  longitudinal & 6-8 transverse bars depending on panel length.
3. Tolerance: The width & thickness of PowerPanel<sup>XL</sup> panels are manufactured to a tolerance of +1 or -1.5mm.
4. Cutting: Panels typically to be no less than 270mm wide. Where narrower panels are used, these panels must not be less than 100mm in width and must be installed between full width panels. Reinforced fibreglass mesh to be embedded in base levelling coat across the full width of the narrower panel.  
In cases where the installation is such that a panel as narrow as 100mm in width is to be installed on its own i.e such as between two adjacent window or door openings, then this installation method is deemed acceptable provided that this narrow panel can be cut, handled and installed without the panel cracking or becoming damaged (damaged or cracked panels must be discarded). In these cases, reinforced fibreglass mesh is to also be embedded in base levelling coat across the full width of this narrow panel.

# APPENDIX B: POWERPANEL<sup>XL</sup> EXTERNAL WALL SYSTEM DESCRIPTIONS

## C.1: Hebel PowerPanel<sup>XL</sup> External Wall System - timber stud frame

CSR Code	Description					
	Platerboard	Stud frame	Batts	Wall wrap	Top hat cavity	Hebel Panel
CSR21716	10mm Gyprock Plasterboard Plus	70mm timber Stud frame	None	Polyair Performa 4.0 XHD	24mm	75mm thick Hebel PowerPanel <sup>XL</sup>
CSR21717			70mm Bradford Soundscreen Batts R2.0	Thermoseal Wall Wrap XP		
CSR21718			70mm Bradford Soundscreen Batts R2.0	Enviroseal™ RW Plus		
CSR21721			None	Polyair Performa 4.0 XHD	35mm	
CSR21722			70mm Bradford Soundscreen Batts R2.0	Thermoseal Wall Wrap XP		
CSR21723			70mm Bradford Soundscreen Batts R2.0	Enviroseal™ RW Plus		
CSR21726		90mm timber Stud frame	None	Polyair Performa 4.0 XHD	24mm	
CSR21727			90mm Bradford Gold Wall Batts R2.0	Thermoseal Wall Wrap XP		
CSR21728			90mm Bradford Gold Wall Batts R2.5	Enviroseal™ RW Plus		
CSR21730			90mm Bradford Gold Wall Batts R2.7	Enviroseal™ RW Plus		
CSR21733			None	Polyair Performa 4.0 XHD	35mm	
CSR21734			90mm Bradford Gold Wall Batts R2.0	Thermoseal Wall Wrap XP		
CSR21735			90mm Bradford Gold Wall Batts R2.5	Enviroseal™ RW Plus		
CSR21737			90mm Bradford Gold Wall Batts R2.7	Enviroseal™ RW Plus		

C.2: Hebel PowerPanel<sup>XL</sup> External Wall System - steel stud frame

CSR Code	Description					
	Platerboard	Stud frame	Batts	Wall wrap	Top hat cavity	Hebel Panel
CSR21706	10mm Gyprock Plasterboard Plus	64mm steel Stud frame	None	Polyair Performa 4.0 XHD	24mm	75mm thick Hebel PowerPanel <sup>XL</sup>
CSR21707			70mm Bradford Soundscreen Batts R2.0	Thermoseal Wall Wrap XP		
CSR21708			70mm Bradford Soundscreen Batts R2.0	Enviroseal™ RW Plus		
CSR21711			None	Polyair Performa 4.0 XHD	35mm	
CSR21712			70mm Bradford Soundscreen Batts R2.0	Thermoseal Wall Wrap XP		
CSR21713			70mm Bradford Soundscreen Batts R2.0	Enviroseal™ RW Plus		
CSR21740		92mm steel Stud frame	None	Polyair Performa 4.0 XHD	24mm	
CSR21741			90mm Bradford Gold Wall Batts R2.0	Thermoseal Wall Wrap XP		
CSR21742			90mm Bradford Gold Wall Batts R2.5	Enviroseal™ RW Plus		
CSR21744			90mm Bradford Gold Wall Batts R2.7	Enviroseal™ RW Plus		
CSR21747			None	Polyair Performa 4.0 XHD	35mm	
CSR21748			90mm Bradford Gold Wall Batts R2.0	Thermoseal Wall Wrap XP		
CSR21749			90mm Bradford Gold Wall Batts R2.5	Enviroseal™ RW Plus		
CSR21751			90mm Bradford Gold Wall Batts R2.7	Enviroseal™ RW Plus		



### CSR HEBEL

Trinity 3, 39 Delhi Road  
North Ryde NSW 2113, Australia  
Telephone +61 2 9235 8000

### Health & safety

Information on any known health risks of our products and how to handle them safely is on product packaging and / or the accompanying documentation.

Additional information is listed in the Safety Data Sheet (SDS). To obtain a copy of a SDS, download from [www.hebel.com.au](http://www.hebel.com.au). Contractors are required by law to perform their own risk assessments before undertaking work.

### Performance & certification

Hebel® products and systems are developed in Australia by CSR Building Products. ABN. 55 008 631 356. It is a manufacturer and supplier of Hebel Autoclaved Aerated Concrete (AAC) products. Because it is a manufacturer and supplier only, CSR does not employ people qualified as Accredited or Principal Certifiers.

CSR is therefore unable to provide Construction Compliance Certificates or Statements of Compliance. CSR conducts appropriate testing of its products and systems to determine performance levels. These include structural, fire and acoustic tests. Testing is conducted and certified by appropriate specialists in these fields. When using Hebel products and systems in specific projects, such specialists should be consulted to ensure compliance with the Building Code of Australia and relevant Australian Standards.

### Disclaimer

The products referred to in this document have been manufactured by or on behalf of CSR Building Products Limited ("CSR") to comply with the Building Code of Australia and any relevant Australian Standards. While any design or usage guidelines set out in this document have been prepared in good faith by CSR, they are of a general nature only and are intended to be used in conjunction with project specific design and engineering advice.

It is the responsibility of the customer to ensure that CSR's products are suitable for their chosen application, including in respect of project-specific matters such as, but not limited structural adequacy, acoustic, fire resistance/combustibility, thermal, and weatherproofing requirements. All information relating to design/installation/application of these products is offered without warranty and no responsibility can be accepted by CSR for errors and omissions, or for any use of the relevant products not in accordance with CSR's technical literature or any other relevant industry standards. For current technical and warranty documentation relating to CSR's products, visit [www.hebel.com.au](http://www.hebel.com.au)

### Other

The design of a wall, floor or fence system requires the services of professional consultants. This document has been prepared as a source of information to provide general guidance to those consultants – and in no way replaces the services of the professional consultant and relevant engineers designing the project.

No liability can therefore be accepted by CSR or other parties for the use of this document. Hebel products and systems undergo constant research and development to integrate new technology and reflect ongoing performance enhancement.

Hebel systems are constantly reviewed so as to reflect any changes in legislative building requirements and or general developments in common building practice, due to our commitment to continual development and improving our building systems.

We advise that all users of this document should regularly check that this document is current, and they are applying our latest design information.

The latest editions of our documents are available on our website:  
[www.hebel.com.au](http://www.hebel.com.au)

Hebel® is a registered trademark of the Xella group. CSR Building Products Ltd is an exclusive licensee of Xella. CSR Hebel is a business of CSR Building Products Ltd ABN 55 008 631 356.

CSR, PowerPanel®, PowerClad®, Hebel Block®, PowerFloor®, Hebel Floor®, PowerFence®, HighBuild®, are registered trademarks of CSR Building Products Limited.

## THE BETTER WAY TO BUILD

Hebel is a quality building product, and is backed by CSR Building Products Limited.

For more information visit our website:

[www.hebel.com.au](http://www.hebel.com.au)

For sales enquiries or further information, please telephone us from anywhere in Australia:

1300 369 448

Working Safely with Hebel

[www.hebel.com.au/working-safely-hebel/](http://www.hebel.com.au/working-safely-hebel/)

