

How to build on-trend Curves and Arches with Hebel



Introducing Curved Blocks and Arched Panels

At Hebel, we're constantly developing new products that meet the needs of our customers. Hebel Curves and Arches have been designed to deliver the stylish, on trend look that's precise, easy to install and works seamlessly with Hebel's external cladding system.

Arches are ideal for doorways, front entrances and windows, while curves can be used for corners of the facade and entrances.

Elevate Your Design: Experience the Beauty of Hebel Curves and Arches

Transform your building's aesthetic with Hebel's innovative curves and arches, where strength meets elegance. Our external cladding system effortlessly integrates beautifully crafted arches, perfect for doorways, front entrances, and windows, creating inviting focal points that draw the eye. Meanwhile, our graceful curves offer on-trend design solutions for facade corners and entrances.

Whether you aim to make a striking statement or achieve a cohesive architectural flow, Hebel's curves and arches deliver the versatility and durability you need. Elevate your project with our unique offerings that blend CSR-quality with style, lasting appeal, and liveable comfort. Experience the Hebel difference - because there's only one Hebel!



Hebel Arched Panels

A pre-manufactured ready-made arched panel that integrates with Hebel's 75mm residential external wall system. Available in 2400mm, 1800mm and 1200mm panel widths.



Hebel Curved Blocks

A 400mm radius tight Curved Block that integrates with Hebel's 75mm residential external wall system.



External Wall System

Seamlessly integrates into Hebel's versatile external cladding system providing a complete wrap-around solution.



Precision Made

Curved Blocks are pre-machined, delivering a highly accurate and consistent curved finish ensuring repeatable builds.



Easy & Fast Install

Delivered to site ready to install, no need for cutting or shaping on site, resulting in less onsite preparation.



Hebel Technology

Access to technical expertise, design services and onsite training for support throughout the installation process.

Arched Panels are delivered ready to create arched window, door and entrance openings.

Hebel's factory-made Arched Panels are designed for effortless installation. Simply replace your hand-cut panels with our reliable, pre-made components that ensure precision and speed, helping you achieve the perfect look with ease.



Benefits of Hebel Arched Panels

Ready to Install: Delivered to your site pre-made, eliminating the need for cutting or shaping, which significantly reduces on-site preparation time.

Seamless Integration: Designed to fit effortlessly into the 75mm residential external wall system without altering fixing details, simplifying the building process.

Enhanced Value: Achieve superior quality outcomes while maximising the value of your project.

Cost-Effective Installation: Easier to install and repeatable, leading to lower labor costs and reduced waste on site.

Experience the efficiency and precision of Hebel Arched Panels, transforming your building process!

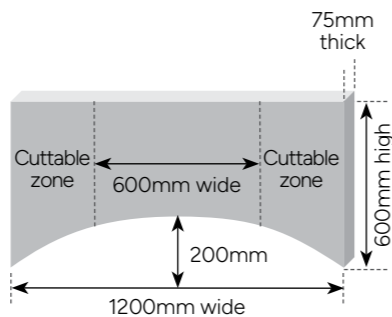
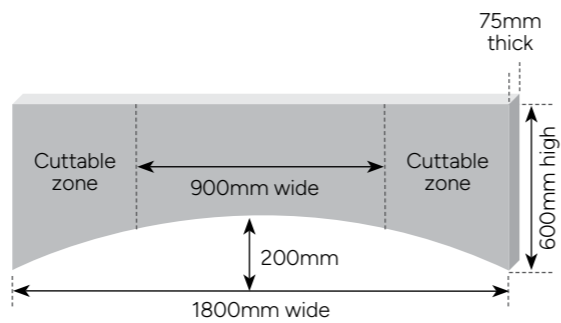
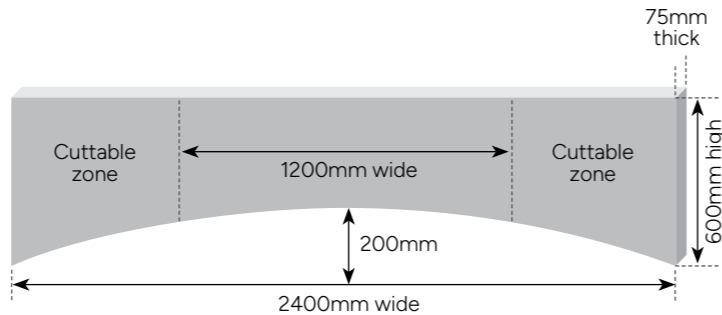

Sizes

Arched Panels are available in three sizes:

- 2400mm wide x 600mm deep x 75mm thick
- 1800mm wide x 600mm deep x 75mm thick
- 1200mm wide x 600mm deep x 75mm thick

Panels can be cut down to suit your requirements by cutting equally on either side of the panel.

- The 2400mm Arched Panel can be cut down to a min 1200mm wide panel.
- The 1800mm Arched Panel can be cut down to a min 900mm wide panel.
- The 1200mm Arched Panel can be cut down to a min 600mm wide panel.
- Sharp and perfect arch ready to install and render.
- The reinforcement mesh has been specially designed to suit the pre cut arch in the panel.
- No risk of rust spotting on the inside on the arch, no need to line with fibre cement.

Installing Arched Panels with the PowerPanel^{XL} walling system

Installing Hebel Arched Panels is just as straightforward as using standard hand-shaped panels. Enjoy the same installation process while benefiting from the precision and efficiency of pre-made components, making your project faster and more reliable.

Installation Steps

Step 1 - Install Top Hats

Install Top Hat sections over wall wrap as detailed in the PowerPanel^{XL} External Walls Design & Installation Guide.

Fix additional Top Hat sections so the Arched Panel is held in place by two Top Hat sections.

Position at:

- 100mm above the highest point of the Arched Panel and
- 100mm below the top of panel

Wall wrap

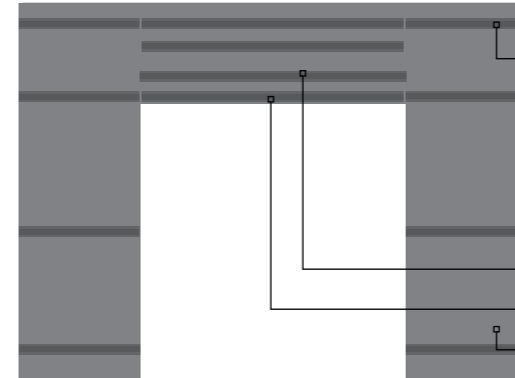

Step 2 - Install Temporary Support blocks

Screw temporary timber support blocks to the frame at the location where the Arched Panel ends will sit. This will provide additional support and ensure the correct positioning for the Arched Panel installation.

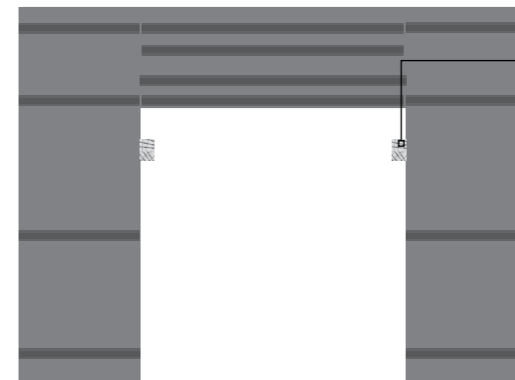

Step 3 - Install PowerPanel^{XL} panel & Arched Panel

Install one side of the opening with PowerPanel^{XL} as detailed in the PowerPanel^{XL} External Walls Design & Installation Guide.

Then install the Arched Panel so it rests/is supported by the timber supports, and screw fix the Arched Panel onto the Top Hats using 14-10 x 90 Hex head Type 17 screws at 200mm centres for each top hat. This is suitable for up to N5/C3 Wind Category.

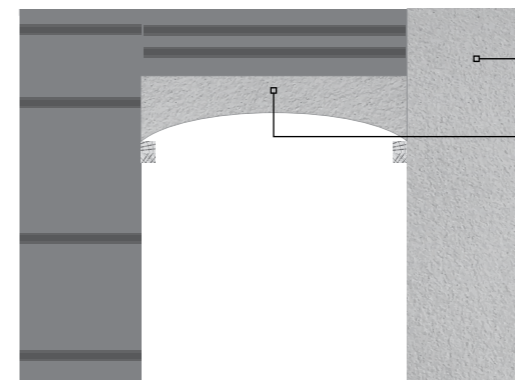

Step 4 - Install PowerPanel^{XL} panels

Continue to complete PowerPanel^{XL} installation above and to the sides of the Arched Panel as detailed in the Hebel PowerPanel^{XL} External Walls Design & Installation Guide, including appropriate control joints.

Once all panels are secure, remove the temporary timber support blocks.

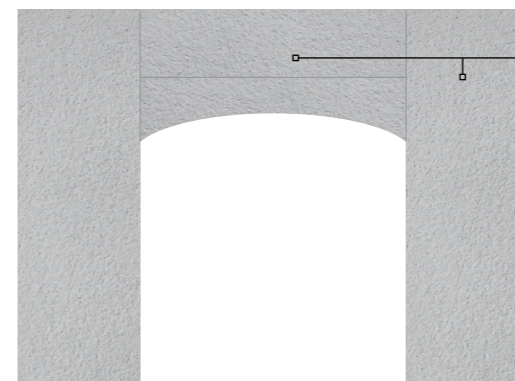

Important Reminder

For comprehensive guidance on wall construction, be sure to consult the Houses and Low Rise Multi Residential PowerPanel^{XL} External Walls Design & Installation Guide. This resource provides detailed instructions to ensure a successful and efficient installation process. Don't overlook it for optimal results!



Hebel Curved Blocks delivered ready to create curved internal & external corners

Hebel Curved Blocks provide a precise, dependable, and ready-to-install solution for achieving the popular tight curved corner design trend. These components streamline your installation process, saving valuable time on site while ensuring consistent quality.



Benefits of Hebel Curved Blocks

- Effortless Installation:** Hebel Curved Blocks provide a cohesive and repeatable installation process, making your project smoother.
 - Precision Engineering:** Pre-machined for a highly accurate and consistent curved finish, ensuring quality and repeatability in every build.
 - Seamless Integration:** Designed to fit perfectly into the 75mm PowerPanel^{XL} residential external wall system, enhancing efficiency in your building process.
 - Simple Connection Method:** Enjoy an easy and straightforward connection, simplifying the installation.
 - Minimal Framing Requirements:** Only a basic clipped corner on the stud frame is needed, making setup quicker and easier.
 - Ready to Install:** Delivered pre-made, eliminating the need for on-site cutting or shaping and reducing preparation time significantly.
- Experience the advantages of Hebel Curved Blocks for a faster, more efficient building process!

Size

External radius 400mm x 200mm high x 600mm wide x 75mm thick



Installing Hebel Curved Blocks with the PowerPanel^{XL} Walling System

Discover the straightforward installation process of Hebel Curved Blocks within the PowerPanel^{XL} walling system. This integration offers a seamless approach, ensuring efficient assembly while enhancing design versatility. Enjoy the benefits of quick installation and a polished finish, all while maintaining the structural integrity and performance of your build.

Experience how easy it is to achieve stunning curved designs with Hebel!

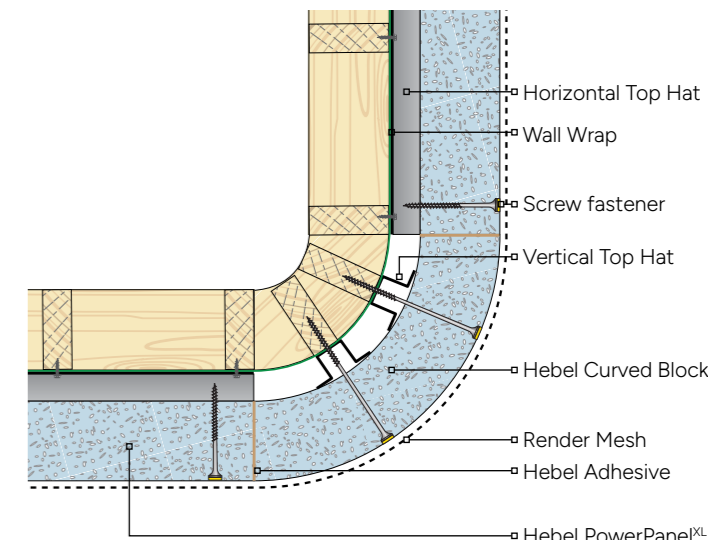

Framing

Set up the framing to suit the required 'curve' in the wall to allow the Hebel Curved Blocks to touch the adjoining panels.

Ensure you have your trades confirm if they can construct the frame to suit the required Curved Block connection.

Top Hats

- Vertical Top Hats are to be the same size as the horizontal Top Hats of the Hebel panel system.
- 400mm radius blocks require 2 vertical Top Hats (and studs).

Screws

Screw fix vertical Top Hats to frame e.g. 12-11 35mm Hex head

- 2x 150mm 14-10 screws are required per block, per Top Hat. Ensure a minimum 50mm edge distance from top and bottom of block.

Glued

- Curved Blocks are to be stacked and glued to each other and adjacent panels with Hebel Adhesive.

Control Joints

- When installing with Hebel PowerPanel walling system, a vertical control joint is required within 1.2m of the Curved Block.
- A horizontal control joint is required between blocks where a horizontal control joint is provided between Hebel panels.

Second storey: When extending Curved Blocks to a second storey, **ensure** that Curved Blocks are supported by a minimum of three non compressible packers at the horizontal control joint.

Render Mesh

Render mesh must be installed up the entire height of the Hebel block corner, and continue across at least one full panel width either side of the corner.

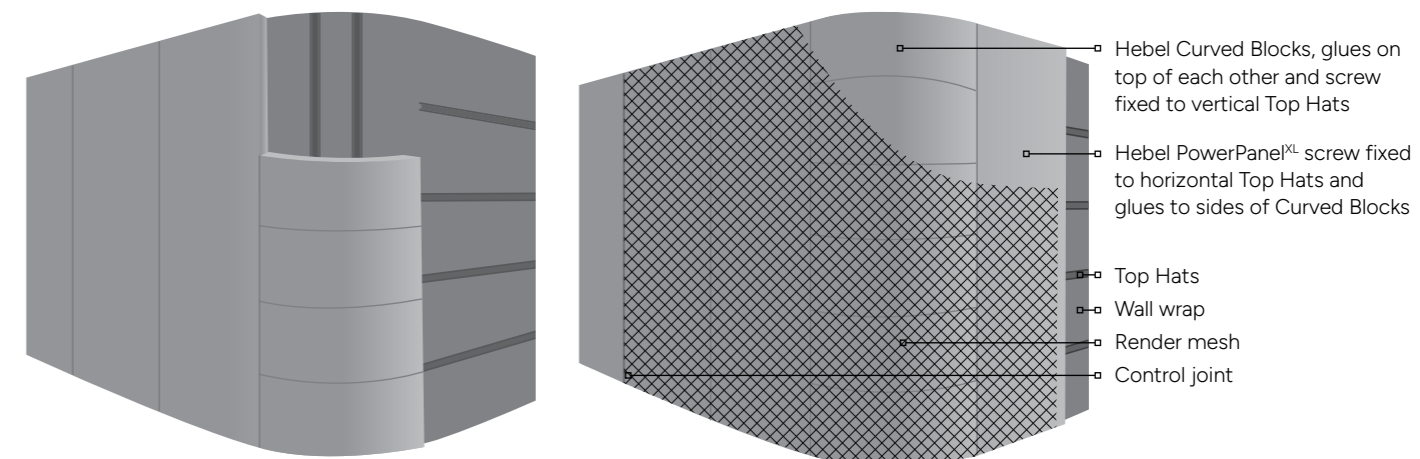

Important Reminder

For comprehensive guidance on wall construction, be sure to consult the Houses and Low Rise Multi Residential PowerPanel^{XL} External Walls Design & Installation Guide. This resource provides detailed instructions to ensure a successful and efficient installation process. Don't overlook it for optimal results!



Creating a Curved Wall with Faceted Hebel Panels

Achieving a stunning curved wall with Hebel panels is simple with the faceting and shaping technique. This approach allows for seamless cutting and moulding of the panels around corners, resulting in a visually striking design that upholds structural integrity. With the expert guidance of “the Hebel way,” you can create unique curves without compromising on quality or performance in your build. Enjoy the flexibility and elegance that Hebel panels bring to your project!

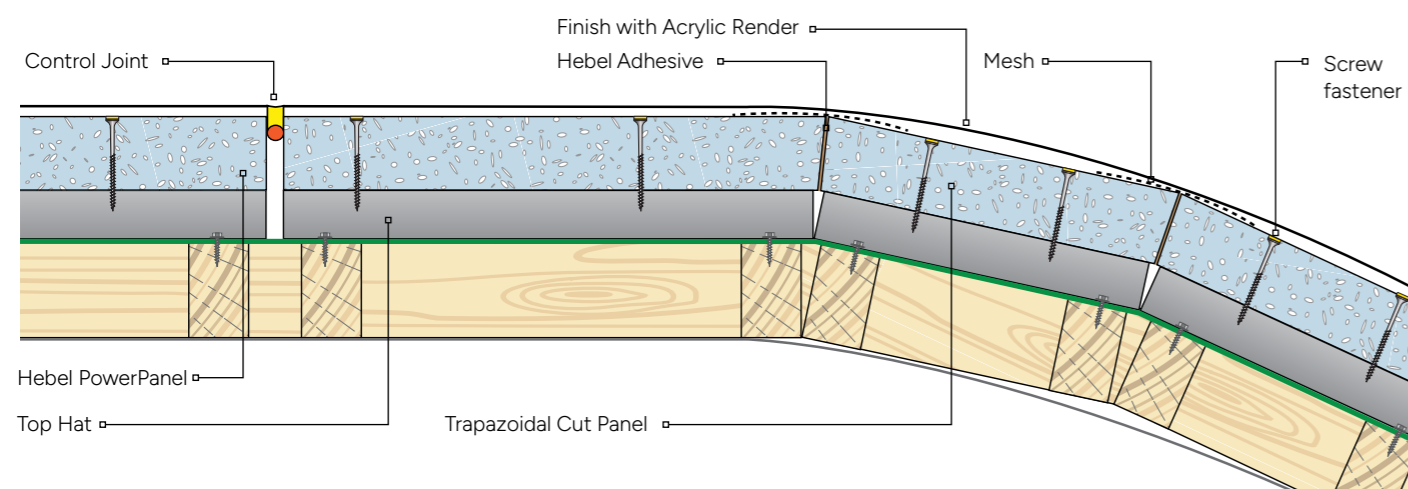
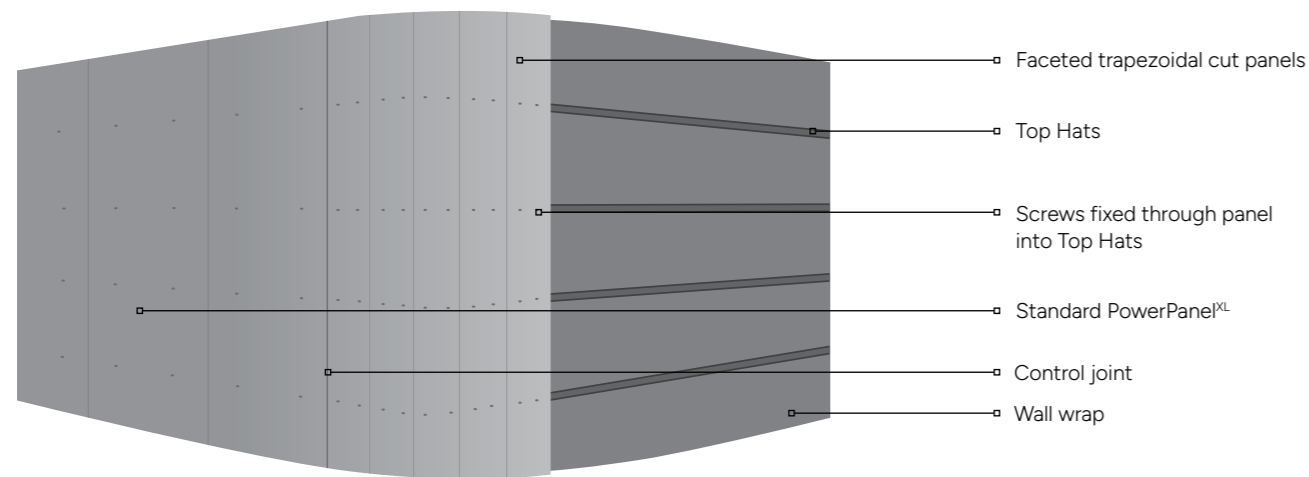

Installing a faceted curve with PowerPanel^{XL} Walling System

Discover the straightforward installation process of Hebel Curved Blocks within the PowerPanel^{XL} walling system. This integration offers a seamless approach, ensuring efficient assembly while enhancing design versatility. Enjoy the benefits of quick installation and a polished finish, all while maintaining the structural integrity and performance of your build. Experience how easy it is to achieve stunning curved designs with Hebel!

Framing

Set up the framing to suit the desired ‘curve’ in the wall to allow the faceted Hebel panels to butt into each other. Ensure you have your trades confirm if they can construct what is required with the desired finish.

Structural

If the panels are not supported at the base on concrete, the stud frame will need to be designed to support the weight of the entire system, including render.

Panel width

For a typical external wall system, the minimum panel width is 300mm with vertical panels and horizontal Top Hats.

Studs

A minimum of 2 studs per panel will be required to support the short sections of Top Hats (supporting the panels).

Outer radius options

Theoretical examples using 300mm width – Hebel PowerPanel 75mm

Render thickness	Outer radius that can be achieved
10mm max render thickness	2500mm outer radius may be achieved.
12mm max render thickness	2000mm outer radius may be achieved.
30mm max render thickness	1000mm outer radius may be achieved

Top Hats

Top Hats legs must not be cut as they need to remain continuous over the angle changes at studs.

Cutting & Control Joints

A triangular piece is cut off the edge of the panel to make ‘trapezoidal’ panels. This ensures the two sides of the Hebel panel butt into each other. Allow a constant 2-3mm thick Hebel adhesive at the joint. Glued joints are then meshed, ready for the finished wall rendered.

Be sure that the curve is smooth flowing around the corner to avoid noticeable angle changes on the finished wall. If not done correctly, these angle changes will be visible after rendering.

Standard control joints are required between straight wall and curved wall.

Screws

Screw fix through panels into Top Hats.

Render & Render mesh

Consider the minimum and maximum thickness of the coating system required to achieve the curve. Seek advice from your coating/render manufacturer to confirm if the min and max render thickness you require can be achieved.

Avoid excessive render thickness which may not adhere to the Hebel (considering the weight) or may lead to cracking from thermal movement.

Internal lining considerations

Ensure the desired internal lining can achieve the internal radius or angle change at studs.

Table 1 and 2 cover the limits of Gyprock Boards.

The absolute minimum internal radius is 450mm with vertical 6.5mm Flexible Gyprock.

Table 1: Curving Radii and Maximum Stud Spacing for 6.5, 10, 13 and 16mm Gyprock Plasterboard

Plasterboard Thickness	Gyprock Flexible Plasterboard	Gyprock Plus, Standard and Flexible Plasterboard ONLY				All Gyprock Plasterboard (excluding perforated and Soundchek products)	
	Curve Radius (mm)						
	<900	900 - 2000	2001 - 2500	2501 - 3000	3001 - 4000	>4000	
Maximum Stud Spacing (mm)							
6.5	Refer to table 2	150	300	350	450	550	
10	-	150	300	350	400	500	
13	-	-	250	300	400	500	
16	-	-	-	-	250	350	

Table 2: Minimum Curving Radius and Maximum Spacing for Gyprock Flexible Plasterboard

Application	Sheets Installed Vertically		Sheets Installed Horizontally	
	Minimum Radius	Maximum Stud Spacing	Minimum Radius	Maximum Stud Spacing
Concave	450mm	150mm	650mm	200mm
Convex	250mm	125mm	450mm	200mm

Notes:

- Low temperature and humidity will reduce board flexibility.
- Our Codemark certificate and design and installation guide does not cover curved walls and therefore needs to be approved by the project certifier.
- Ensure you use this document in conjunction with the Houses and Low Rise Multi Residential PowerPanel^{XL} External Walls Design & Installation Guide.
- For curved internal lining options refer to RedBook 2 or 3 "Curved Walls" section for details.

Important Reminder

For comprehensive guidance on wall construction, be sure to consult the Houses and Low Rise Multi Residential PowerPanel^{XL} External Walls Design & Installation Guide. This resource provides detailed instructions to ensure a successful and efficient installation process. Don't overlook it for optimal results!



Disclaimer: The products referred to in this document have been manufactured by or on behalf of CSR Building Products Limited ("CSR") to comply with the Building Code of Australia and any relevant Australian Standards. While any design or usage guidelines set out in this document have been prepared in good faith by CSR, they are of a general nature only and are intended to be used in conjunction with project specific design and engineering advice. It is the responsibility of the customer to ensure that CSR's products are suitable for their chosen application, including in respect of project-specific matters such as, but not limited to structural adequacy, acoustic, fire resistance/combustibility, thermal, and weatherproofing requirements. All information relating to design/ installation/ application of these products is offered without warranty and no responsibility can be accepted by CSR for errors and omissions, or for any use of the relevant products not in accordance with CSR's technical literature or any other relevant industry standards. For current technical and warranty documentation relating to CSR's products, visit www.hebel.com.au

Credits: Page 2 - Metricon Homes / Page 3 - Cornerstone, photography Mini Cooke / Fairmont Homes / Page 4 Metricon Homes / Page 6 Latitude37 Homes / Page 8 Fairmont Homes.

Contact us

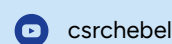
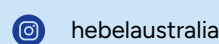
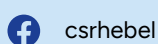
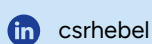

For more Working Safely with Hebel information, scan the QR code, visit our website hebel.com.au or contact us on 1300 712 896.

